

TECHNICAL MANUAL
OPERATOR, ORGANIZATIONAL, DIRECT
SUPPORT AND GENERAL SUPPORT
MAINTENANCE MANUAL

LANDING CRAFT UTILITY
LCU 1671-1679
NSN 1905-01-009-1056

APPENDIX A	REFERENCES
B	MAINTENANCE ALLOCATION CHART
C	COMPONENTS OF END ITEMS AND BASIC ISSUE ITEMS
D	ADDITIONAL AUTHORIZATION LIST
E	EXPANDABLE SUPPLIES AND MATERIALS LIST
F	MANUFACTURED TOOLS
	INDEX

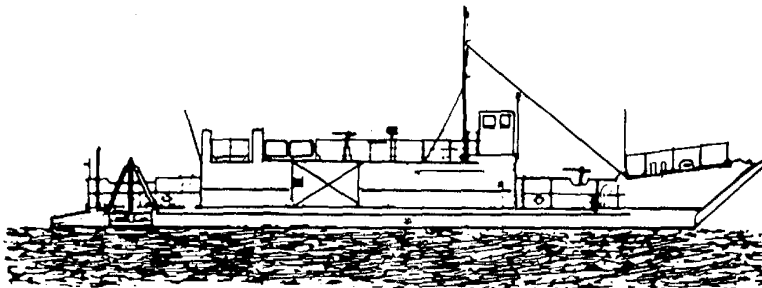

CHANGE
NO. 6

HEADQUARTERS
DEPARTMENT OF THE ARMY
WASHINGTON, D.C., 10 October 1996

Operator, Organizational, Direct
Support and General Support
Maintenance Manual

LANDING CRAFT UTILITY
LCU 1671 - 1679
NSN 1905-01-009-1056

DISTRIBUTION STATEMENT A: Approved for public release; distribution is unlimited.

TM 55-1905-220-14-12, 29 April 1985, is changed as follows:

1. Remove and insert pages as indicated below. New or changed text material is indicated by a vertical bar in the margin. An illustration change is indicated by a miniature pointing hand.

Remove pages
i/(ii blank)
A-1/(A-2 blank)
C-7 and C-8

Insert pages
i/(ii blank)
A-1 and A-2
C-7 and C-8
C-8.1/(C-8.2 blank)
C-129/(C-130 blank)

2. Retain this sheet in front of manual for reference purposes.

By Order of the Secretary of the Army:

DENNIS J. REIMER
General, United States Army
Chief of Staff

Official:

JOEL B. HUDSON
Administrative Assistant to the
Secretary of the Army
02782

DISTRIBUTION:

To be distributed in accordance with DA Form 12-25-E, block no. 1060, requirements for TM 55-1905-220-14-12.

CHANGE

NO. 5

Operator, Organizational, Direct Support and General Support
Maintenance Manual

LANDING CRAFT UTILITY
LCU 1671-1679
NSN 1905-01-009-1056

DISTRIBUTION STATEMENT A: Approved for public release; distribution is unlimited.

TM 55-1905-220-14-12, 29 April 1985, is changed as follows:

1. Remove and insert pages as indicated below. New or changed text material is indicated by a vertical bar in the margin. An illustration change is indicated by a miniature pointing hand.

Remove pages

Insert pages

i/(ii blank)

B-1 through B-44

C-125/(C-126 blank)

D-7/(D-8 blank)

i/(ii blank)

B-1 through B-44

C-125 through C-128

D-7/(D-8 blank)

2. Retain this sheet in front of manual for reference purposes.

By Order of the Secretary of the Army:

GORDON R. SULLIVAN
General, United States Army
Chief of Staff

Official:

MILON H. HAMILTON
Administrative Assistant to the
Secretary of the Army
07114

DISTRIBUTION:

To be distributed in accordance with DA Form 12-25-E, block no. 1060, requirements for TM 55-1905-220-14-12.

CHANGE

NO. 4

Operator, Organizational, Direct Support and
General Support Maintenance Manual

LANDING CRAFT UTILITY

LCU 1671-1679

NSN 1905-01-009-1056

DISTRIBUTION STATEMENT A: Approved for public release; distribution is unlimited.

TM 55-1905-220-14-12, 29 April 1985 is changed as follows:

1. Remove and insert pages as indicated below. New or changed text material is indicated by a vertical bar in the margin. An illustration change is indicated by a miniature pointing hand.

Remove pages

Insert pages

D-7/(D-8 blank)

D-7/D-8 blank)

2. Retain this sheet in front of manual for reference purposes.

By Order of the Secretary of the Army:

GORDON R. SULLIVAN
General, United States Army
Chief of Staff

Official:

MILTON H. HAMILTON
Administrative Assistant to the
Secretary of the Army
0429

DISTRIBUTION:

To be distributed in accordance with DA Form 12-25-E, block no. 1060, requirements for TM 55-1905-220-14-12.

CHANGE

NO. 3

HEADQUARTERS
DEPARTMENT OF THE ARMY
WASHINGTON, D.C., 9 SEPTEMBER 1992

Operator, Organizational, Direct Support and General Support
Maintenance Manual
LANDING CRAFT UTILITY
LCU 1671-1679
NSN 1905-01-009-1056

Approved for public release; Distribution is unlimited

TM 55-1905-220-14-12, 29 April 1985 is changed as follows:

1. Remove and insert pages as indicated below. New or changed text material is indicated by a vertical bar in the margin. An illustration change is indicated by a miniature pointing hand.

Remove pages	Insert pages
C-19 through C-24	C-19 through C-24

2. Retain this sheet in front of manual for reference purposes.

By Order of the Secretary of the Army:

GORDON R. SULLIVAN
General, United States Army
Chief of Staff

Official:

MILTON H. HAMILTON
*Administrative Assistant to the
Secretary of the Army*
02422

DISTRIBUTION:

To be distributed in accordance with DA Form 12-25-E, block 1060, Operator, Unit, Direct and General Support Maintenance requirements for TM 55-1905-220-14-12.

CHANGE

NO. 2

HEADQUARTERS
DEPARTMENT OF THE ARMY
WASHINGTON, D.C., 31 DECEMBER 1991

Operator, Organizational, Direct Support and General Support
Maintenance Manual

LANDING CRAFT UTILITY
LCU 1671-1679
NSN 1905-01-009-1056

Approved for public release; distribution is unlimited

TM 55-1905-220-14-12, 29 April 1985 is changed as follows:

1. Remove and insert pages as indicated below. New or changed text material is indicated by a vertical bar in the margin. An illustration change is indicated by a miniature pointing hand.

Remove pages	Insert pages
B-1 through B-36	B-1 through B-44
Index-3 and Index-4	Index-3 and Index-4
Index-9 and Index-10	Index-9 and Index-10
Index-19 and Index-20	Index-19 and Index-20
Index 51 and Index-52	index 51 and Index-52
Index-59/(Index-60 blank)	Index-59/(Index-60 blank)

2. Retain this sheet in front of manual for reference purposes.

By Order of the Secretary of the Army:

GORDON R. SULLIVAN
General, United States Army
Chief of Staff

Official:

MILTON H. HAMILTON
*Administrative Assistant to the
Secretary of the Army*
00419

DISTRIBUTION:

To be distributed in accordance with DA Form 12-25E, (qty rqr block no. 1060).

CHANGE

No. 1

Operator, Organizational, Direct Support and General Support
Maintenance Manual

LANDING CRAFT UTILITY
LCU 16710-1679
NSN 1905-01-009-1056

Approved for public release; distribution is unlimited

TM 55-1905-220-1012, 29 April 1985 is changed as follows:

1. Remove and insert pages as indicated below. New or changed text material is indicated by a vertical bar in the margin. An illustration change is indicated by a miniature pointing hand.

Remove pages
E-15 and E-16

Insert pages
E-15 and E-16

2. Retain this sheet in front of manual for reference purposes.

By Order of the Secretary of the Army:

CARL E. VUONO
General, United States Army
Chief of Staff

Official:

THOMAS F. SIKORA
Brigadier General, United States Army
The Adjutant General

DISTRIBUTION:

To be distributed in accordance with DA Form 12-25E, (qty rqr block no. 1060).

TECHNICAL MANUAL
 ARMY
 NO. 55-1905-220-14-12

HEADQUARTERS
 DEPARTMENT OF THE
 WASHINGTON, D.C., 29 April 1985

Operator, Organizational, Direct
 Support and General Support
 Maintenance Manual

LANDING CRAFT UTILITY
LCU 1671 - 1679
NSN 1905-01-009-1056

REPORTING ERRORS AND RECOMMENDING IMPROVEMENTS

You can help improve this manual. If you find any mistakes, or if you know of a way to improve these procedures, please let us know. Mail your letter or DA Form 2028 (Recommended Changes to Publications and Blank Forms), or DA Form 2028-2 located in the back of this manual directly to: Commander, US Army Aviation and Troop Command, ATTN: AMSAT-I-MP, 4300 Goodfellow Blvd., St. Louis, MO 63120-1798. You may also submit your recommended changes by E-mail directly to <mpmtl/oavma28@st-louis-emh7.army.mil>. A reply will be furnished directly to you. Instructions for sending an electronic 2028 may be found at the back of this manual immediately preceding the hard copy 2028.

DISTRIBUTION STATEMENT A: Approved for public release; distribution is unlimited.

TABLE OF CONTENTS

	PAGE
APPENDIX A REFERENCES	A-1
APPENDIX B MAINTENANCE ALLOCATION CHART	B-1
APPENDIX C COMPONENTS OF END ITEM AND BASIC ISSUE ITEMS LISTS	C-1
APPENDIX D ADDITIONAL AUTHORIZATION LIST	D-1
APPENDIX E EXPENDABLE SUPPLIES AND MATERIALS LIST	E-1
APPENDIX F MANUFACTURED TOOLS	F-1
INDEX.....	INDEX-1

Change 6 i/(ii blank)

APPENDIX A
REFERENCES

- 1. Fire Protection**

TB 5-4200-200-10 Hand Portable Fire Extinguishers for Army Users
- 2. Lubrication**

C91001 L Fuels, Lubricants, Oil, and Waxes
- 3. Painting**

TM 9-213 Painting Instructions for Field Use
- 4. Cleaning**

C680011 Cleaning and Chemical Products
- 5. Maintenance**

TM 55-1905-220-20P Unit Maintenance Repair Parts and Special Tools List

TM 55-1905-220-34P Direct Support, and General Support Maintenance Repair Parts and Special Tools List

DA Pam 738-750 The Army Maintenance Management System (TAMMS)
- 6. Shipment and Storage**

TB 740-244-3 Preservation and Packing of Military Equipment

TB 740-93-2 Preservation of Mechanical Equipment for Shipment and Storage
- 7. Demolition**

TM 750-244-3 Destruction of Material to Prevent Enemy Use

APPENDIX A

REFERENCES - CONTINUED

8. **Communications, Electronics, Navigation (CEN) Equipment Commercial Manuals**

	Alden Electronics SATFIND-406 M3 EPIRB Owner's Manual
	Alden TR-IV Marinefax Technical Manual and Operator's Manual
Instruction Book No. 71261 Rev. C and Instruction Book Cat. No. 120 and 122 No. 509754	Belfort Instrument Company Aerovane Indicator Model 135
	Bendix/King EPH/EPI Series Portable Radio Owner's Manual
	Bendix/King EPH Series Portable Radio Service Manual
	Bendix/King LAA Series Battery Chargers Service Manual
	Dymek DA100D All Wave Receiving Antenna Owner Information Manual
	Mackay Communications 403A Emergency Lifeboat Transceiver Instruction Manual
	Naval Electronics Inc. MK22CAPba 2205 System Installation and Service Manual
	Newmar Heavy Duty DC-DC Converters Operation and Installation Instructions
RMC Document Number G261404 Rev A	Raytheon Marine Company Radar Set Model R40X/R41X AN/SPS-69 Description, Operation and Maintenance Technical Manual
	Ross Engineering DSC 500 Digital Selective Call Marine VHF Transceiver Operating Manual
TM-8080000701	Sunair Electronics, Inc. Digital Automatic Antenna Coupler DCU-100 Operation and Maintenance Manual

Appendix B. MAINTENANCE ALLOCATION CHART (MAC)

SECTION I. INTRODUCTION

B-1 THE ARMY MAINTENANCE SYSTEM MAC.

a This introduction (Section I) provides a general explanation of all maintenance and re- pair functions authorized at various maintenance levels under the standard Army Maintenance System concept.

b The Maintenance Allocation Chart (MAC) in Section II designates overall authority and responsibility for the performance of maintenance functions on the identified end item or component. The application of the maintenance functions to the end item or component will be consistent with the capacities and capabilities of the designated maintenance levels, which are shown in the MAC in column (4) as:

Unit - includes two subcolumns: C (operator/crew) and O (unit) maintenance.

Direct Support - includes an F subcolumn.

General Support - includes an H subcolumn.

Depot - includes a D subcolumn.

c **Section III** lists the tools and test equipment (both special tools and common tools sets) required for each maintenance function as referenced from Section II.

d **Section IV** contains supplemental instructions and explanatory notes for a particular maintenance function as referenced from Section II.

B-2 MAINTENANCE FUNCTIONS. Maintenance functions will be limited to and defined as follows:

a **Inspect.** To determine the serviceability of an item by comparing its physical, mechanical, and/or electrical characteristics with established standards through examination (i.e., by sight, sound, or feel).

b **Test.** To verify serviceability by measuring the mechanical, pneumatic, hydraulic, or electrical characteristics of an item and comparing those characteristics with prescribed standards.

c **Service.** Operations required periodically to keep an item in proper operating condition, i.e., to clean (includes decontamination, when required), to replace filters, to preserve, to drain, to paint, or to replenish fuel, lubricants, chemical fluids, or gases.

d **Adjust.** To maintain or regulate, within prescribed limits, by bringing into proper or exact position, or by setting the operating characteristics to specified parameters.

e **Align.** To adjust specified variable elements of an item to bring about optimum or desired performance.

f **Calibrate.** To determine and cause corrections to be made or to be adjusted on instruments or test, measuring, and diagnostic equipment used in precision measurement. Consists of comparisons of two instruments, one of which is a certified standard of known accuracy, to detect and adjust any discrepancy in the accuracy of the instrument being compared.

g **Remove/Install.** To remove and install the same item when required to perform service or other maintenance functions. Install may be the act of emplacing, seating, or fixing into position a spare, repair part, or module (component or assembly) in a manner to allow the proper functioning of an equipment or system.

h **Replace.** To remove an unserviceable item and install a serviceable counterpart in its place. Replace is authorized by the MAC and is shown as the 3rd position code of the SMR code.

i Repair. The application of maintenance services¹ including fault location/trouble- shooting², removal/installation, and disassembly/assembly³ procedures, and maintenance actions to identify troubles and restore serviceability to an item by correcting specific damage, fault, malfunction, or failure in a part, subassembly, module (component or assembly), and item, or system.

j Overhaul. That maintenance effort (service/action) prescribed to restore an item to a completely serviceable/operational condition as required by maintenance standards in appropriate technical publications (i.e., DMWR). Overhaul is normally the highest degree of maintenance performed by the Army. Overhaul does not normally return an item to like new condition.

k Rebuild. Consists of those service/actions necessary for the restoration of unserviceable equipment to a like new condition in accordance with original manufacturing standards. Rebuild is the highest degree of material maintenance applied to Army equipment. The rebuild operation includes the act of returning to zero those age measurements (hours, miles, etc.) considered in classifying Army equipment and components.

B-3 EXPLANATION OF COLUMNS IN THE MAC, SECTION II

a Column 1 - Group Number. Column 1 lists functional group code numbers, the purpose of which is to identify maintenance significant components, assemblies, subassemblies, and modules with the next higher assembly.

b Column 2 - Component/Assembly. Column 2 contains the names of components, assemblies, subassemblies, and modules for which maintenance is authorized.

c Column 3 - Maintenance Function. Column 3 lists the functions to be performed on the item listed in column 2. (For detailed explanation of these functions, see paragraph A-2.)

d Column 4 - Maintenance Category. Column 4 specifies, by the listing of a work time figure in the appropriate subcolumn(s), the category of maintenance authorized to perform the function listed in Column 3. This figure represents the active time required to perform that maintenance function at the indicated category of maintenance. If the number or complexity of the tasks within the listed maintenance function varies at different maintenance categories, appropriate work time figures will be shown for each category. The work time figure represents the average time required to restore an item (assembly, subassembly, component, module, end item, or system) to a serviceable condition under typical field operating conditions. This time includes preparation time (including any necessary disassembly/assembly time), troubleshooting/fault location time, and quality assurance/quality control time in addition to the time required to perform the specific tasks identified for the maintenance functions authorized in the maintenance allocation chart. The symbol designations for the various maintenance categories are as follows:

- C Operator or Crew
- O Unit Maintenance
- F Direct Support Maintenance (DS)
- H General Support Maintenance (GS)
- D Depot Maintenance

¹Service - Inspect, test, service, adjust, align, calibrate, and/or replace.

²Fault location/troubleshooting - The process of investigating and detecting the cause of equipment malfunctioning; the act of isolating a fault within a system or unit under test (UUT).

³Disassembly/assembly - The step-by-step breakdown (taking apart) of a spare/functional group coded item to the level of its least component, that is assigned an SMR code for the level of maintenance under consideration (i.e., identification as maintenance significant).

⁴Actions - Welding, grinding, riveting, straightening, facing, machining, and/or resurfacing.

e Column 5 - Tools and Equipment. Column 5 specifies, by number code, those common tool sets (not individual tools); special tools; Test, Measurement, and Diagnostic Equipment (TMDE); and support equipment required to perform the designated function, which shall be keyed to the tools listed in Section III.

f Column 6 - Remarks. This column shall, when applicable, contain a letter code, in alphabetic order, which shall be keyed to the remarks contained in Section IV.

B-4 EXPLANATION OF COLUMNS IN TOOL AND TEST EQUIPMENT REQUIREMENTS, SECTION III.

a Column 1 - Reference Code. The tool and test equipment reference code correlates with a number code used in the MAC, Section II, Column 5.

b Column 2 - Maintenance Category. The lowest category of maintenance authorized to use the tool or test equipment.

c Column 3 - Nomenclature. Name or identification of the tool or test equipment.

d Column 4 - National Stock Number. The National stock number (NSN) of the tool or test equipment.

e Column 5 - Tool Number. The manufacturer's part number.

B-5 EXPLANATION OF COLUMNS IN REMARKS, SECTION IV.

a Column 1 - Reference Code. The letter code recorded in Column 6, Section II.

b Column 2 - Remarks. This column lists information pertinent to the maintenance function being performed as indicated in the MAC, Section II.

SECTION II. MAINTENANCE ALLOCATION CHART (CONTINUED)

(1) GROUP NUMBER	(2) COMPONENT/ ASSEMBLY	(3) MAINTENANCE FUNCTION	(4) MAINTENANCE LEVEL					(5) TOOLS AND EQUIPMENT	(6) REMARKS
			UNIT		DS	GS	DEPOT		
			C	O	F	H	D		
0100	Propulsion Unit, (Engine/Marine Gear)								
0101	Engine	Inspect	0.2						
		Test	1.0		8.0				
		Service	2.0						
		Replace			100.0				
		Repair	1.5		18.0				
		Overhaul					*	1,2	
0101A	Marine Gear	Inspect	0.2						
		Test	1.0		8.0				
		Service	2.0						
		Replace			100.0				
		Repair	1.5		18.0				
		Overhaul					*		
0102	Engine/Transmission Controls	Inspect	0.3						
		Test	0.2						
		Service	0.2						
		Adjust	1.0						
		Replace	10.0						
		Repair	1.0		10.0				
0102A	Emergency Shut Down	Inspect	0.3						
		Test	0.2						
		Replace	10.0						
		Repair	1.0		10.0				
0102B	Alarm System	Inspect	0.3						
		Test	0.2						
		Replace	10.0						
		Repair	1.0		10.0				
0103	Governor	Inspect	0.1						
		Test	1.0						
		Service	0.2						
		Adjust	0.2						
		Replace	0.4						
		Repair	1.0					3,4,5,6	

SECTION II. MAINTENANCE ALLOCATION CHART (CONTINUED)

(1) GROUP NUMBER	(2) COMPONENT/ ASSEMBLY	(3) MAINTENANCE FUNCTION	(4) MAINTENANCE LEVEL					(5) TOOLS AND EQUIPMENT	(6) REMARKS
			UNIT		DS	GS	DEPOT		
			C	O	F	H	D		
0104	Air Intake	Inspect	0.2						
		Service	0.2						
		Replace	3.5						
		Repair	1.5						
0105	Blower	Inspect	0.2				8, 9 7		
		Service	0.2						
		Replace	1.5						
		Repair	1.0						
0106	Fuel Pump	Inspect	0.2				10, 11		
		Replace	1.0						
		Repair	1.5						
0107	Fuel Filter, Strainer and Fuel Lines	Inspect	0.1						
		Service	0.5						
		Replace	2.0						
		Repair	1.5						
0108	Fuel Injector	Inspect	0.1				14 12,13,15		
		Test	0.3		0.5				
		Service	0.2						
		Replace	1.5						
		Repair	1.5						
0109	Lube Oil Filters and Housing	Inspect	0.2						
		Service	0.4						
		Replace	1.5						
		Repair	1.4		1.5 (weld)				
0110	Oil Cooler	Inspect	0.1						
		Replace	1.2						
		Repair	1.5		2.5				
0111	Fresh Water Pump	Inspect	0.2				11,16,17,18, 19,21,51		
		Replace	1.2						
		Repair	2.5		3.0				
							D		

SECTION II. MAINTENANCE ALLOCATION CHART (CONTINUED)

(1) GROUP NUMBER	(2) COMPONENT/ ASSEMBLY	(3) MAINTENANCE FUNCTION	(4) MAINTENANCE LEVEL					(5) TOOLS AND EQUIPMENT	(6) REMARKS
			UNIT		DS	GS	DEPOT		
			C	O	F	H	D		
0112	Expansion Tank	Inspect	0.1						
		Service	0.2						
		Test	0.5						
		Replace	2.5						
		Repair	1.7		2.5				
0113	Water Connections	Inspect	0.2						
		Replace	2.0						
0114	Water Manifold	Inspect	0.2						
		Replace	1.5						
		Repair			3.0(weld)				
0116	Thermostat and Housing	Inspect	0.2						
		Test	0.5						
		Replace	0.4						
		Repair	1.3		2.0(weld)				
0118	Tachometer Drive	Inspect	0.1						
		Replace	1.6						
		Repair	2.0						
0119	Instrument Panel	Inspect	0.1						
		Replace	1.5						
		Repair	2.0						
0120	Crankshaft Pulley and Vibration Darnpener	Inspect	0.2						
		Replace	3.0				21, 53		
		Repair			2.5				
0121	Balance Weight Cover and Accessory Drive	Inspect	0.2					53	
		Replace	2.5						
		Repair	3.5						
0122	Engine Supports, Lift Brackets and Crankshaft Front Cover	Inspect	0.1						
		Replace	0.5						
		Repair			1.5				
0123	Exhaust Manifold and Fittings	Inspect	0.2					53	
		Replace	3.0						
		Repair	3.0		3.0				

SECTION II. MAINTENANCE ALLOCATION CHART (CONTINUED)

(1) GROUP NUMBER	(2) COMPONENT/ ASSEMBLY	(3) MAINTENANCE FUNCTION	(4) MAINTENANCE LEVEL					(5) TOOLS AND EQUIPMENT	(6) REMARKS
			UNIT		DS	GS	DEPOT		
			C	O	F	H	D		
0123A	Muffler	Inspect	1.0						
		Service	2.0						
		Replace			50.0				
0124	Rocker Arm Cove	Repair			18.0				
		Inspect	0.1						
0125	Injector Controls	Replace	0.2						
		Repair							
0126	Flywheel and Housing	Inspect	0.1						
		Adjust	2.3						
		Replace	2.0						
		Repair	2.7						
0127	Camshaft and Gear Train	Inspect	0.2						
		Replace			4.0		22		
		Repair	2.0		2.0				
0128	Valve Operating Mechanism (per cylinder)	Inspect			0.9				
		Replace			4.5		23, 24, 25		
		Repair			4.0				
0129	Cylinder Head	Inspect	0.2					26	
		Adjust	0.8						
		Replace	2.5						
		Repair	3.2						
0130	Oil Pan and Dipstick	Inspect	0.2						
		Test	0.2						
		Replace	1.5					27, 28, 29, 30, 31,32,33,34	
0131	Lube Oil Relief Valve	Repair	1.5		4.5(weld)				
		Inspect	0.2					28	
		Replace	2.5						
0131A	Lube Oil Regulator	Repair			2.5(weld)				
		Inspect	0.1						
		Replace	1.0						
0131A	Lube Oil Regulator	Repair			1.5				
		Inspect	0.1						
		Replace	1.0						
0131A	Lube Oil Regulator	Repair			15				

SECTION II. MAINTENANCE ALLOCATION CHART (CONTINUED)

(1) GROUP NUMBER	(2) COMPONENT/ ASSEMBLY	(3) MAINTENANCE FUNCTION	(4) MAINTENANCE LEVEL					(5) TOOLS AND EQUIPMENT	(6) REMARKS
			UNIT		DS	GS	DEPOT		
			C	O	F	H	D		
0132	Lube Oil Pump	Inspect	0.2					35,36, 52	
		Replace	1.0						
		Repair	2.0						
0133	Lube Oil Distribution System	Inspect	0.1						
		Replace	2.0						
0134	Pistons, Connecting Rods	Inspect and Liners	1.0					33,34,37,38, 39,40,41,42, 43,44,45,46	
		Replace Repair	4.5		5.5				
0135	Crankshaft Bearing	Inspect	1.0						
		Replace	6.5						
0135A	Crankshaft	Inspect	0.1						
		Replace			2.0				
0135B	Crankshaft Seals	Inspect	0.1						
		Replace			1.0				
0136	Cylinder Block	Inspect	0.3						
		Replace			12.0				
		Repair	1.0		8.5				
0137	Starting Aid	Inspect	0.1						
		Service	0.2						
		Replace	1.5						
		Repair	2.0						
0138	Hydrostarter (Hydrator)	Inspect	0.2					49	B, C
		Test			1.5				
		Replace Repair	1.2 1.2						
0139	Accumulator	Inspect	0.1					48	
		Service			1.0				
		Replace Repair	1.4 3.5						
0140	Hydrostarter Pump (Engine Driven)	Inspect	0.1						
		Replace	0.4						
		Repair			1.8				

SECTION II. MAINTENANCE ALLOCATION CHART (CONTINUED)

(1) GROUP NUMBER	(2) COMPONENT/ ASSEMBLY	(3) MAINTENANCE FUNCTION	(4) MAINTENANCE LEVEL					(5) TOOLS AND EQUIPMENT	(6) REMARKS
			UNIT		DS	GS	DEPOT		
			C	O	F	H	D		
0141	Hydrostarter Pump (Hand) Repair	Inspect	0.1						
		Replace	1.2						
		Repair	2.5						
0142	Hydrostarter Piping (Forward Engine Room)	Inspect	0.2						
		Replace			2.7				
		Repair			1.5				
0143	Hydrostarter Piping (Aft Engine Room)	Inspect	0.2						
		Replace			2.7				
		Repair			1.5				
0144	Reservoirs, Filters and Solenoids	Inspect	0.2						
		Replace	1.0						
		Repair			1.0				
0150	Propeller Shaft and Bearings	Inspect	0.5			5.5		48	E, F
		Adjust	0.4						
		Replace	120		100.0				
		Repair			6.5				
		Overhaul					*		L
0150A	Port Line Shaft	Inspect	0.5						
		Adjust	1.0						
		Repair	3.0						
0150B	Shaft Inflatable Seals	Inspect	0.1						
		Service	4.0						
		Replace			15.0			48	
		Repair	2.0						
0150C	Shaft Seal, Preformed	Inspect	0.1						
		Service			2.0				
		Replace	15.0						
0151	Shaft Lock	Inspect	0.3						
		Replace	4.5		4.0				
0200	Electric Power Generation and Distribution	Overhaul							L

Change 5 B-9

SECTION II. MAINTENANCE ALLOCATION CHART (CONTINUED)

(1) GROUP NUMBER	(2) COMPONENT/ ASSEMBLY	(3) MAINTENANCE FUNCTION	(4) MAINTENANCE LEVEL					(5) TOOLS AND EQUIPMENT	(6) REMARKS
			UNIT		DS	GS	DEPOT		
			C	O	F	H	D		
0205	Switchboard (Main)	Inspect	0.4						
		Replace			24.0				
0208	Transformers	Repair	0.5		25.5				
		Inspect	0.5		0.5				
		Service	1.0		5.5				
		Replace			6.6				
0210	Power Distribution Panel Boards	Repair			3.5				
		Inspect	0.7						
		Replace			4.0				
		Repair	2.5		5.5				
0213	Fuse Panel P-024	Inspect	0.2						
		Replace			4.0				
		Repair	2.5						J
0214	Alarm Distribution Panel	Inspect	0.2						
		Replace			4.0				
		Repair	2.5						
0215	Generator, 12V	Inspect	0.3						
		Service	1.0						
		Test	1.0		2.0				
		Replace	1.0						
		Repair	5.0						
		Overhaul							L
0218	Generator (40KW)	Inspect	0.2						
		Service	2.0						
		Replace	16.0						
		Overhaul							L
0220	Engine Assy	Inspect	0.3						
		Service	1.5						
		Test			8.0				
		Replace			40.0				
		Overhaul	8.5						L

SECTION II. MAINTENANCE ALLOCATION CHART (CONTINUED)

(1) GROUP NUMBER	(2) COMPONENT/ ASSEMBLY	(3) MAINTENANCE FUNCTION	(4) MAINTENANCE LEVEL					(5) TOOLS AND EQUIPMENT	(6) REMARKS
			UNIT		DS	GS	DEPOT		
			C	O	F	H	D		
0221	Engine Controls	Inspect	0.5						
		Adjust	2.0						
		Replace	8.0						
		Repair	2.0						
0221 A	Emergency Stop Solenoid	Inspect	0.5						
		Adjust	0.5						
		Replace	1.0						
		Repair	1.0						
0221 B	Alarm Switches	Inspect	0.3						
		Adjust	0.2						
		Replace	0.5						
		Repair	0.5						
0221 C	Emergency Shut-Off	Inspect	0.5						
		Adjust	0.2						
		Replace	2.0						
		Repair	1.0						
0222	Governor (Hydraulic) and Oil Filters	Inspect	0.2		0.4			3,4,5,6	
		Service	0.2		1.0				
		Test			4.5				
		Adjust	0.2						
		Replace	1.0						
		Repair	1.0						
0223	Air Intake	Inspect	0.2						
		Service	0.4						
		Replace	1.5						
		Repair	3.0						
0224	Blower	Inspect	0.2					7,8,9,49	
		Service	0.4						
		Replace	1.5						
		Repair	1.0						
0225	Fuel Pump and Drain Lines	Inspect	0.2					10, 11	
		Replace	1.0						
		Repair	2.0						

SECTION II. MAINTENANCE ALLOCATION CHART (CONTINUED)

(1) GROUP NUMBER	(2) COMPONENT/ ASSEMBLY	(3) MAINTENANCE FUNCTION	(4) MAINTENANCE LEVEL					(5) TOOLS AND EQUIPMENT	(6) REMARKS
			UNIT		DS	GS	DEPOT		
			C	O	F	H	D		
0226	Fuel Filter and Strainer	Inspect	0.2						
		Service	0.5						
		Replace	1.5						
		Repair	1.5						
0227	Fuel Injector	Inspect	0.1						
		Test	0.3		0.5			12,13,14,15, 50	
		Replace	1.5					12,13,14,15, 50	
0228	Fuel Lines and Manifold Connections	Inspect	0.2						
		Replace	1.5						
0229	Lube Oil Filter and Housing	Inspect	0.2						
		Service	0.4						
		Replace	1.5						
		Repair	1.4		1.5				
0230	Lube Oil Cooler	Inspect	0.2						
		Replace	1.2						
		Repair	1.5		2.5				
0231	Fresh Water Pump	Inspect	0.2						
		Replace	1.2						
		Fresh	19			11		11,16,17, 18,	
		Repair	2.5					11,16,17,18,	
0232	Heat Expansion Tank and Water Connections	Inspect	0.2						
		Replace	1.2						
0233	Water Manifold	Inspect	0.2						
		Replace	1.2						
		Repair			3.0(weld)				
0234	Thermostat and Housing	Inspect	0.2						
		Replace	0.4						
		Repair	1.3		2.0weld)				

SECTION II. MAINTENANCE ALLOCATION CHART (CONTINUED)

(1) GROUP NUMBER	(2) COMPONENT/ ASSEMBLY	(3) MAINTENANCE FUNCTION	(4) MAINTENANCE LEVEL					(5) TOOLS AND EQUIPMENT	(6) REMARKS
			UNIT		DS	GS	DEPOT		
			C	O	F	H	D		
0235	Overspeed Governor	Inspect	0.2						
		Test			1.0				
		Service	1.0						
		Adjust	0.5						
		Replace	1.0						
0236	Tachometer Drive	Repair	1.0						
		Inspect	0.2						
0237	Air Cleaner	Replace	1.6						
		Repair	1.5						
		Inspect	0.1						
023a	Crankshaft Pulley	Service	0.3						
		Replace	1.0						
		Repair	1.0						
		Inspect	0.2					21	
0239	Balance Weight Cover	Replace	2.5						
		Repair			1.7				
		Inspect	0.2	50					
0240	Lilt Brackets and Supports	Replace	1.5						
		Repair	1.0			2.5			
0241	Exhaust	Inspect	0.2						
		Replace	2.0						
		Repair	2.5			2.5			
0242	Rocker Arm Cover	Inspect	0.1						
		Replace	1.0						
0243	Injector Controls	Inspect	0.2						
		Adjust	0.3						
		Replace	1.5						
		Repair	2.0						
0244	Oil Pan, Dipstick, Oil Filter	Inspect	0.2						
		Replace	1.5						
		Repair	1.5					28	

SECTION II. MAINTENANCE ALLOCATION CHART (CONTINUED)

(1) GROUP NUMBER	(2) COMPONENT/ ASSEMBLY	(3) MAINTENANCE FUNCTION	(4) MAINTENANCE LEVEL					(5) TOOLS AND EQUIPMENT	(6) REMARKS
			UNIT		DS	GS	DEPOT		
			C	O	F	H	D		
0245	Cylinder Head	Inspect	0.2					27, 28,29,30, 31,32,33,34	
		Replace 1.5							
0246	Valve Operating Mechanism	Repair	1.5		4.5			26	
		Inspect	0.2						
		Adjust	0.8						
		Replace	1.5						
0247	Camshaft and Gear Train	Repair	2.5					23, 24, 25	
		Inspect	0.4						
		Replace	6.0						
0248	Flywheel and Housing	Repair	3.5					22	
		Inspect	0.2						
		Replace	3.5						
0249	Lube Oil Pressure Regulator	Repair	2.0		2.0(weld)				
		Inspect	0.1						
0250	Lube Oil Pump	Adjust	0.4					35, 36, 52	
		Replace	1.5						
		Repair	2.0						
0251	Lube Oil System	Inspect	0.2						
		Distribution	0.2						
0252	Pistons, Connecting and Cylinder Liners	Replace	1.2					33,34,37,38, 39, 40, 41, 42, 43,44,45,46	
		Rods	1.0						
		Repair	4.5		5.5				
0253	Crankshaft	Inspect	0.5					21	
		Replace	6.5						
	Bearings	Inspect	0.4						
		Replace	1.0						
	Front Cover and Oil Seal	Inspect	0.2						
		Replace	1.0						

SECTION II. MAINTENANCE ALLOCATION CHART (CONTINUED)

(1) GROUP NUMBER	(2) COMPONENT/ ASSEMBLY	(3) MAINTENANCE FUNCTION	(4) MAINTENANCE LEVEL					(5) TOOLS AND EQUIPMENT	(6) REMARKS
			UNIT		DS	GS	DEPOT		
			C	O	F	H	D		
0254	Cylinder Block	Inspect	0.5						
		Replace			10.5				
		Repair	1.0		4.5				
0255	Instrument Panel	Inspect	0.2						
		Replace	1.5						
		Repair	2.0						
0256	Starting Aid	Inspect	0.1						
		Service	0.2						
		Replace	0.5						
		Repair	1.2						
0260	Hydrostarter (Hydrotor)	Inspect	0.2				49		
		Test			1.5				
		Replace Repair	1.2 1.2						
0262	Accumulator	Inspect	0.1						
		Service			1.0				
		Replace Repair	1.4 3.5				48		
0264	Hydrostarter Pump (Engine Driven)	Inspect	0.1						
		Replace	0.4						
		Repair			1.8				
0266	Hydrostarter Pump (Hand)	Inspect	0.1						
		Replace	1.2						
		Repair	2.5						
0267	Hydrostarter Piping (Forward Engine Room)	Inspect	0.2						
		Replace			2.7				
		Repair			1.5				
0268	Hydrostarter Piping (Aft Engine Room)	Inspect	0.2						
		Replace			2.7				
		Repair			1.5				

SECTION II. MAINTENANCE ALLOCATION CHART (CONTINUED)

(1) GROUP NUMBER	(2) COMPONENT/ ASSEMBLY	(3) MAINTENANCE FUNCTION	(4) MAINTENANCE LEVEL					(5) TOOLS AND EQUIPMENT	(6) REMARKS
			UNIT		DS	GS	DEPOT		
			C	O	F	H	D		
0269	Reservoirs	Inspect	0.2						
		Replace	1.0						
		Repair			1.0				
0270	Rectifier, 24 VDC	Inspect	0.5						
		Replace	2.0						
		Repair	2.0						
0272	Distribution Panels Lighting	Inspect	0.1						
		Replace			2.5				
		Repair	1.0						
0274	Switches	Inspect	0.2						
		Replace	1.5						
0274A	Safety Switch, Air Compressor	Inspect	0.1						
		Replace	1.0						
0281	Lights	Inspect	0.2						
		Replace	1.5						
0282	Emergency Lighting	Inspect	0.2						
		Replace	1.5						
		Repair	1.0						
0282A	Rotary Light, Red, Fire Warning	Replace	0.5						
		Repair	1.0						
0282B	Rotary Light, Amber, General Alarm	Replace	0.5						
		Repair	1.0						
0282C	Lamp, Fluorescent, Red and White	Replace	0.5						
		Repair	1.0						
0284	Running, Signal, and Anchor Lights	Inspect	0.2						
		Replace	1.5						
		Repair	1.0						
0285	Navigational Light Control Panel	Inspect	0.2						
		Replace Repair	0.4		10.0				
0300	Bow Ramp and Winch	Overhaul					*	L	

SECTION II. MAINTENANCE ALLOCATION CHART (CONTINUED)

(1) GROUP NUMBER	(2) COMPONENT/ ASSEMBLY	(3) MAINTENANCE FUNCTION	(4) MAINTENANCE LEVEL					(5) TOOLS AND EQUIPMENT	(6) REMARKS
			UNIT		DS	GS	DEPOT		
			C	O	F	H	D		
0310	Bow Ramp, Sheaves, and Fairlead	Inspect	0.7						
		Replace			12.0				
		Repair	3.0						
0320	Winch Assembly	Inspect	0.3						
		Replace			80.0				
		Repair	20.0						
0322	Torque Coupling	Inspect	0.3						
		Replace	2.5						
		Repair	2.5						
0323	Speed Reducer	Inspect	0.3						
		Replace			25.0				
		Repair	1.0						
0324	Winch Brake and Motor	Inspect	0.4						
		Test	1.0						
		Replace			4.5				
		Repair	2.0						
0325	Controller	Inspect	0.2						
		Replace	3.5						
		Repair			2.0				
0326	Master Switch	Inspect	0.3						
		Replace			2.0				
		Repair	2.5						
0327	Limit Switches	Inspect	0.3						
		Replace	1.5						
		Repair	2.0						
0400	Stem Gate	Inspect	0.6						
		Service	1.0						
		Replace			7.0				
		Repair			15.0				
		Overhaul					*	L	

SECTION II. MAINTENANCE ALLOCATION CHART (CONTINUED)

(1) GROUP NUMBER	(2) COMPONENT/ ASSEMBLY	(3) MAINTENANCE FUNCTION	(4) MAINTENANCE LEVEL					(5) TOOLS AND EQUIPMENT	(6) REMARKS
			UNIT		DS	GS	DEPOT		
			C	O	F	H	D		
0410	Gate, Hinges, and Springs	Inspect	0.6						
		Replace			7.0				
		Repair			15.0				
0420	Portable Davit	Inspect	0.3						
		Replace	1.5						
		Repair			3.5				
0500	Anchor Handling System	Overhaul					*	L	
0510	Winch	Inspect	0.3						
		Service	0.4						
		Replace			100.0				
		Repair	2.0	29.0					
0511	Drive Brake	Inspect	0.3						
		Service	0.5						
		Adjust	1.0		1.0				
		Replace	3.0						
		Repair	5.5		7.5				
0512	Drive Gear	Inspect	0.5		2.5				
		Replace			9.0				
		Repair	2.5						
0513	Level Wind	Inspect	0.3						
		Service	0.2						
		Replace			15.0				
		Repair	1.5		5.5				
0514	Drum Assembly	Inspect	0.2						
		Service	0.3						
		Replace			80.0				
		Repair	2.5		4.5				
0515	Slack Puller	Inspect	0.2						
		Service	0.2						
		Replace			20.0				
		Repair	5.0		15.0				

SECTION II. MAINTENANCE ALLOCATION CHART (CONTINUED)

(1) GROUP NUMBER	(2) COMPONENT/ ASSEMBLY	(3) MAINTENANCE FUNCTION	(4) MAINTENANCE LEVEL					(5) TOOLS AND EQUIPMENT	(6) REMARKS
			UNIT		DS	GS	DEPOT		
			C	O	F	H	D		
0516	Disconnect Clutch	Inspect	0.3						
		Service	0.2						
		Replace			4.5				
		Repair			3.5				
0517	Torque Converter	Inspect	0.3						
		Service	0.6						
		Replace			26.0				
		Repair	5.5						
0518	Hydraulic Tank Assembly	Inspect	0.2						
		Service	0.6						
		Replace	3.5						
		Repair	20.0		2.0 (weld)				
0519	Winch Control	Inspect	0.2						
		Service	0.3						
		Replace	2.0						
		Repair	2.5						
0519A	Hoses, Lines, and Fittings	Inspect	0.5						
		Replace	2.5						
		Repair	2.5						
0520	Engine	Inspect	0.3						
		Service	1.0						
		Test			8.0				
		Replace			80.0				
		Repair Overhaul	8.5				*	L	
0521	Diesel Throttle Controls	Inspect	0.2						
		Service	0.3						
		Replace			2.5 (weld)				
		Repair	2.5						

SECTION II. MAINTENANCE ALLOCATION CHART (CONTINUED)

(1) GROUP NUMBER	(2) COMPONENT/ ASSEMBLY	(3) MAINTENANCE FUNCTION	(4) MAINTENANCE LEVEL					(5) TOOLS AND EQUIPMENT	(6) REMARKS
			UNIT		DS	GS	DEPOT		
			C	O	F	H	D		
0522	Governor	Inspect	0.2					3,4,5,6	
		Test			1.0				
		Replace Repair	1.0 1.0						
0523	Air Intake	Inspect	0.2						
		Service	0.4						
		Replace	1.5						
		Repair	3.0						
0524	Blower	Inspect	0.3					7,8,9	
		Service	0.4						
		Replace	2.0						
		Repair	1.0						
0525	Fuel Pump	Inspect	0.2					10,11	
		Replace	1.0						
		Repair			1.5				
0526	Fuel Filter and Strainer	Inspect	0.2						
		Service	0.5						
		Replace	1.5						
		Repair	1.5						
0527	Fuel Injector	Inspect	0.1					12,13,14 12,13,14,15 50	
		Test	0.3		0.5				
		Replace	1.5						
		Repair	1.5						
0528	Lube Oil Filter, Hoses and Housing	Inspect	0.2						
		Service	0.4						
		Replace	1.5						
		Repair	1.4						
0529	Lube Oil Cooler	Inspect	0.2						
		Replace	1.2						
		Repair	1.5						

SECTION II. MAINTENANCE ALLOCATION CHART (CONTINUED)

(1) GROUP NUMBER	(2) COMPONENT/ ASSEMBLY	(3) MAINTENANCE FUNCTION	(4) MAINTENANCE LEVEL					(5) TOOLS AND EQUIPMENT	(6) REMARKS
			UNIT		DS	GS	DEPOT		
			C	O	F	H	D		
0530	Fresh Water Pump	Inspect	0.2					11,16,17 18,19,51	
		Replace	1.2						
		Repair			2.5				
0531	Water Connections	Inspect	0.2						
		Repair	1.5						
0532	Water Manifold	Inspect	0.2						
		Replace	1.2						
		Repair	1.0		3.0 (weld)				
0533	Thermostat and Housing	Inspect	0.2						
		Replace	1.4						
		Repair	1.3		2.0 (weld)				
0534	Overspeed Governor	Inspect	0.2						
		Test	1.0						
		Adjust	0.5						
		Replace	1.0						
		Repair	1.0						
0535	Tachometer Drive	Inspect	0.2						
		Replace	1.6						
		Repair	1.5						
0535A	Air Cleaner	Inspect	0.1						
		Service	0.3						
		Replace	1.0						
		Repair	1.0						
0536	Crankshaft Pulley and Vibration Dampener	Inspect	0.2					21,47	
		Replace	2.5						
		Repair	1.7						
0537	Balance Weight and Cover	Inspect	0.3					47	
		Replace	1.5						
0538	Engine Supports and Lifting Brackets	Inspect	0.4						
		Replace	2.5						
		Repair	1.0						

SECTION II. MAINTENANCE ALLOCATION CHART (CONTINUED)

(1) GROUP NUMBER	(2) COMPONENT/ ASSEMBLY	(3) MAINTENANCE FUNCTION	(4) MAINTENANCE LEVEL					(5) TOOLS AND EQUIPMENT	(6) REMARKS
			UNIT		DS	GS	DEPOT		
			C	O	F	H	D		
0539	Exhaust Manifold	Inspect	0.2						
		Replace	2.5						
		Repair	2.5		2.5 (weld)				
0540	Rocker Arm Cover	Inspect	0.1						
		Replace	1.0						
0541	Injector Controls	Inspect	0.2						
		Adjust	0.3						
		Replace	1.5						
		Repair	2.0						
0542	Oil Pan and Dipstick	Inspect	0.2						
		Replace	1.5						
		Repair	1.5						
0543	Cylinder Head	Inspect	0.2				27, 28,29 30,31,32 33,34		
		Replace	1.5						
		Repair	1.5						
0544	Valve Operating Mechanism	Inspect	0.2						
		Adjust	0.8						
		Replace	1.5				26		
		Repair	2.5						
0545	Camshaft and Gear Train	Inspect	0.4				23,24,25		
		Replace	6.0						
		Repair	3.5						
0546	Flywheel and Housing	Inspect	0.2						
		Replace	3.5				22		
		Repair	2.0	2.0	2.0			I	
0547	Lube Oil Pressure Regulator Valve	Inspect	0.1						
		Adjust	0.4						
		Replace	1.0						
		Repair	1.5						
0548	Lube Oil Pump	Inspect	0.2						
		Replace	1.0				35,36,52		
		Repair	2.0						

SECTION II. MAINTENANCE ALLOCATION CHART (CONTINUED)

(1) GROUP NUMBER	(2) COMPONENT/ ASSEMBLY	(3) MAINTENANCE FUNCTION	(4) MAINTENANCE LEVEL					(5) TOOLS AND EQUIPMENT	(6) REMARKS
			UNIT		DS	GS	DEPOT		
			C	O	F	H	D		
0549	Lube Oil Distribution System	Inspect Replace	0.2 1.5						
0550	Pistons, Connecting Rods and Liners	Inspect Replace Repair	1.0 4.5 5.5				33,34,37 38,39,40 41,42,43 44,45,46		
0551	Crankshaft	Inspect Replace	0.5 6.5				21		
0551A	Bearings, Mains	Inspect Replace	0.5 6.5				21,47		
0552	Cylinder Block	Inspect Replace Repair	0.5 1.0		10.5 4.5				
0553	Instrument Panel	Inspect Replace Repair	0.1 1.5 2.0						
0554	Starting Aid	Inspect Service Replace Repair	0.1 0.2 1.5 2.0						
0560	Hydrostarter (Hydrotor)	Inspect Test Replace Repair	0.2 1.5 1.2		1.5		49		
0561	Accumulator	Inspect Service Replace Repair	0.1 1.4		1.0 3.5		48		
0562	Hydrostarter Pump (Engine Driven)	Inspect Replace Repair	0.2 1.2		2.5				

SECTION II. MAINTENANCE ALLOCATION CHART (CONTINUED)

(1) GROUP NUMBER	(2) COMPONENT/ ASSEMBLY	(3) MAINTENANCE FUNCTION	(4) MAINTENANCE LEVEL					(5) TOOLS AND EQUIPMENT	(6) REMARKS
			UNIT		DS	GS	DEPOT		
			C	O	F	H	D		
0563	Hydraulic Pump (Hand)	Inspect	0.2						
		Replace	1.0						
		Repair	3.5						
0564	Reservoir	Inspect	0.2						
		Replace	1.9						
		Repair			1.0				
0565	Hydraulic Filter and Hoses	Inspect	0.2						
		Replace	2.0						
		Repair	1.0		2.0				
0570	"A" Frame, Wire Rope and Anchor	Inspect	0.5						
		Service	1.0						
		Replace				2.0			
		Repair				1.0			
0571	Fairlead	Inspect	0.2						
		Service	0.3						
		Replace			6.0				
0572	Wire Rope Cutter	Inspect	0.5						
		Repair	4.0						
0600	Mast	Inspect	0.5						
		Service	0.5						
		Replace				12.0			
		Repair	5.5		29.0				
0700	Ship's Hydraulic System	Service Overhaul	0.2					*	
0710	Hydraulic Power Unit								
0711	Electric Motor	Inspect	0.2		1.0				
		Replace	1.5						
		Repair			7.5				
0712	Hydraulic Pump	Inspect	0.3						
		Replace	3.5						
		Repair			5.5				

SECTION II. MAINTENANCE ALLOCATION CHART (CONTINUED)

(1) GROUP NUMBER	(2) COMPONENT/ ASSEMBLY	(3) MAINTENANCE FUNCTION	(4) MAINTENANCE LEVEL					(5) TOOLS AND EQUIPMENT	(6) REMARKS
			UNIT						
			C	O	F	H	D		
0713	Relief Valve	Inspect	0.3						
		Adjust	0.5						
		Replace	1.0						
		Repair	0.5		2.0				
0714	Hydraulic Reservoir	Inspect	0.3						
		Replace	2.5						
		Repair	1.0		3.0				
0715	Controller	Inspect	0.3						
		Replace	2.5						
		Repair			4.5				
0716	Gages	Inspect	0.5						
		Replace	1.3						
0717	Push Button Switch	Inspect	0.2						
		Replace	1.7						
		Repair	1.0						
0720	Stem Gate Hydraulic System								
0721	Hydraulic Control	Inspect	0.4						
		Replace	3.0						
		Repair			10.5				
0723	Hoses, Fittings and Pipings	Inspect	0.5						
		Replace	4.2		10.5				
0724	Hydraulic Ram	Inspect	0.5						
		Replace	3.5						
		Repair			10.5				
0730	Mast Hydraulic System								
0731	Hydraulic Ram	Inspect	0.5						
		Replace	3.5						
		Repair			10.5				
0732	Hydraulic Control	Inspect	0.4						
		Replace	3.0						
		Repair			10.5				

SECTION II. MAINTENANCE ALLOCATION CHART (CONTINUED)

(1) GROUP NUMBER	(2) COMPONENT/ ASSEMBLY	(3) MAINTENANCE FUNCTION	(4) MAINTENANCE LEVEL					(5) TOOLS AND EQUIPMENT	(6) REMARKS
			UNIT		DS	GS	DEPOT		
			C	O	F	H	D		
0734	Hoses and Fittings	Inspect Replace	0.5 4.7		11.0				
0740	Stern Anchor Hydraulic System								
0741	Hydraulic Winch	Inspect Replace Repair	0.5 3.0 2.0		10.5				
0742	Hydraulic Control	Inspect Replace Repair	0.4 3.0		10.5				
0743	Hoses and Fittings	Inspect Replace	0.5 4.2						
0800	Steering Systems	Overhaul					*	L	
0810	Motor	Inspect Replace Repair	0.3 2.0 2.0		7.0				
0811	Motor Controller	Inspect Replace Repair	0.5 2.5		4.5				
0812	Hydraulic Pump	Inspect Replace Repair	0.3 2.0 2.0		7.0				
0813	Brake Valve	Inspect Replace Repair	0.3 2.5		4.5				
0814	Directional Control Valve	Inspect Replace Repair	0.3 2.5 4.5						
0815	Hydraulic Cylinder and Linkage	Inspect Adjust Replace Repair	1.0 1.0 1.8		15.0 13.0				

SECTION II. MAINTENANCE ALLOCATION CHART (CONTINUED)

(1) GROUP NUMBER	(2) COMPONENT/ ASSEMBLY	(3) MAINTENANCE FUNCTION	(4) MAINTENANCE LEVEL					(5) TOOLS AND EQUIPMENT	(6) REMARKS
			UNIT		DS	GS	DEPOT		
			C	O	F	H	D		
0816	Hydraulic Hoses, Piping and Valves	Inspect	1.0						
		Replace			15.0				
		Repair	2.0		12.0				
0817	Main and Flanking Rudders	Inspect			4.0				
		Replace			20.0				
		Repair			10.0				
0820	Rudder Angle Indicator	Inspect	0.5						
		Replace			4.0				
		Repair	1.5						
0821	Rudder Angle Transmitter	Inspect	0.5						
		Replace	4.0						
		Repair	1.0						
0830	Flanking Rudder Unit Switch	Inspect	0.2						
		Replace	1.0						
		Repair	0.2						
0840	Steering Control Panel and Gyro Computer	Inspect	0.5						
		Replace	2.5						
		Repair	2.0					G	
0850	Heading Selector	Inspect	0.5						
		Replace	0.5						
		Repair	1.5						
0860	Remote Magnetic Heading Compass	Inspect	0.5						
		Adjust			2.5				
		Replace			7.0				
		Calibrate			3.5			H	
0870	Emergency Steering System	Inspect	1.0						
		Replace	2.0						
		Repair	2.5						

SECTION II. MAINTENANCE ALLOCATION CHART (CONTINUED)

(1) GROUP NUMBER	(2) COMPONENT/ ASSEMBLY	(3) MAINTENANCE FUNCTION	(4) MAINTENANCE LEVEL					(5) TOOLS AND EQUIPMENT	(6) REMARKS
			UNIT		DS	GS	DEPOT		
			C	O	F	H	D		
0880	Ship's Course Indicator	Inspect	0.7						
		Replace	5.0						
		Repair	12.5		40.0				
0900	Pump Sets	Overhaul					*	L	
0910	Portable Fire Pump Set	Inspect	0.6						
		Service	1.2						
		Test		1.5					
		Adjust	1.5						
		Replace Repair	5.0 3.5						
0911	Fire Pump	Inspect	0.2						
		Service	0.4						
		Replace	2.5						
		Repair	2.0		3.5				
0912	Motor	Inspect	0.2						
		Service	0.4						
		Replace	5.0						
		Repair	2.5		4.5				
0913	Controller (Starter)	Inspect	0.2						
		Replace		3.5					
		Repair	2.0	4.0					
0920	Bilge Pump Set								
0921	Pump	Inspect	0.4						
		Service	0.5						
		Replace	4.5						
		Repair	2.5		5.0				
0922	Foundation and Drive	Inspect	0.2						
		Replace	3.0		3.5				
		Repair	3.0		1.5				

SECTION II. MAINTENANCE ALLOCATION CHART (CONTINUED)

(1) GROUP NUMBER	(2) COMPONENT/ ASSEMBLY	(3) MAINTENANCE FUNCTION	(4) MAINTENANCE LEVEL					(5) TOOLS AND EQUIPMENT	(6) REMARKS
			UNIT		DS	GS	DEPOT		
			C	O	F	H	D		
0930	Lube Oil Pump Set	Inspect	0.4						
		Service	0.5						
		Replace	5.0						
		Repair	8.5						
0931	Pump	Inspect	0.2						
		Replace	4.0						
		Repair	2.5		4.5				
0932	Motor	Inspect	0.2						
		Replace	1.5						
		Repair	2.5		4.5				
0933	Controller (Starter)	Inspect	0.2						
		Replace			3.5				
		Repair	2.0		6.0				
0940	Fresh Water Pump Set	Inspect	0.4						
		Replace	5.0						
		Repair	2.5						
0941	Pump	Inspect	0.2						
		Replace	2.5						
		Repair	7.5						
0942	Motor	Inspect	0.2						
		Replace	2.5						
		Repair	2.5		4.5				
0943	Controller (Starter)	Inspect	0.2						
		Replace	3.5						
		Repair	2.0		6.0				
0950	Air Conditioning Water Circulating Pump Set	Inspect	0.4						
		Replace	5.5						
		Repair	8.0						
0951	Pump	Inspect	0.2						
		Replace	3.5						
		Repair	2.0		6.5				

SECTION II. MAINTENANCE ALLOCATION CHART (CONTINUED)

(1) GROUP NUMBER	(2) COMPONENT/ ASSEMBLY	(3) MAINTENANCE FUNCTION	(4) MAINTENANCE LEVEL					(5) TOOLS AND EQUIPMENT	(6) REMARKS
			UNIT		DS	GS	DEPOT		
			C	O	F	H	D		
0952	Motor	Inspect	0.2						
		Replace	1.5						
		Repair	2.5		4.5				
0953	Controller (Starter)	Inspect	0.2						
		Replace	3.5						
		Repair	2.0		4.0				
0960	Diesel Oil Cooling Pump Set	Inspect	0.4						
		Replace	5.5						
		Repair	5.0						
0961	Pump	Inspect	0.2						
		Replace	3.5						
		Repair	4.5						
0962	Motor	Inspect	0.2						
		Replace	3.5						
		Repair	2.5		4.5				
0963	Controller (Starter)	Inspect	0.2						
		Replace	3.5						
		Repair	4.0						
0970	Lube Oil Transfer Pump (Hand)	Inspect	0.2						
		Service	0.2						
		Replace	2.0						
		Repair	2.0						
1000	Sewage System	Overhaul					*	L	
1010	Sewage System Discharge Pump	Inspect	0.4						
		Service	0.5						
		Replace	6.0						
		Repair	5.5		3.5				
1011	Pump	Inspect	0.2						
		Service	0.3						
		Replace	3.5						
		Repair	4.5						

SECTION II. MAINTENANCE ALLOCATION CHART (CONTINUED)

(1) GROUP NUMBER	(2) COMPONENT/ ASSEMBLY	(3) MAINTENANCE FUNCTION	(4) MAINTENANCE LEVEL					(5) TOOLS AND EQUIPMENT	(6) REMARKS
			UNIT						
			C	O	F	H	D		
1012	Motor	Inspect	0.2						
		Service	0.2						
		Replace	3.8						
		Repair	5.0						
1020	Sewage System Macerator/Transfer Pump	Inspect	0.4						
		Service	2.0						
		Replace	3.0						
		Repair	2.0						
1021	Motor	Inspect	0.2						
		Replace	3.5						
		Repair	2.0		4.5				
1030	Sewage System Air Pump	Inspect	0.3						
		Service'	0.2						
		Replace	3.0						
		Repair	2.0						
1031	Motor	Inspect	0.4						
		Replace	3.5						
		Repair	2.0		4.5				
1040	Toilet	Inspect	0.2						
		Service	0.7						
		Replace	3.8						
		Repair	5.0						
1050	Urinal	Inspect	0.2						
		Replace	2.0						
		Repair	2.0						
1060	Controller (Starter)	Inspect	0.2						
		Replace	3.5						
		Repair	2.0		4.0				
1070	Sewage System Piping	Inspect	1.0						
		Replace			20.0				
		Repair	2.0		18.0				

SECTION II. MAINTENANCE ALLOCATION CHART (CONTINUED)

(1) GROUP NUMBER	(2) COMPONENT/ ASSEMBLY	(3) MAINTENANCE FUNCTION	(4) MAINTENANCE LEVEL					(5) TOOLS AND EQUIPMENT	(6) REMARKS
			UNIT		DS	GS	DEPOT		
			C	O	F	H	D		
1080	Sewage Holding Tank	Inspect	0.5						
		Service	2.5						
		Replace			90.0				
		Repair	2.5						
1100	Heating, Ventilation and Air Conditioning System (HVAC)	Overhaul					*	L	
1111	HVAC Supply, Fan and Motor Sets	Inspect	0.5						
		Service	1.0						
		Replace	5.0						
		Repair	2.5		5.0				
1112	HVAC Ducting	Inspect	0.7						
		Service	1.2						
		Replace			13.5				
		Repair			7.5				
1121	HVAC Exhaust System Fan and Motor Sets	Inspect	0.5						
		Service	1.0						
		Replace	5.0						
		Repair	2.5		5.0				
1131	HVAC Heating System Heaters	Inspect	0.5						
		Service	1.0						
		Replace	3.0						
		Repair	2.5						
1140	HVAC Air Conditioning System								
1141	Compressor	Inspect	0.3						
		Service	1.0		6.0				
		Replace			2.5				
		Repair	2.0		6.5				
1142	Condenser	Inspect	3.0						
		Service	1.0						
		Replace	3.5						
		Repair	4.5						

SECTION II. MAINTENANCE ALLOCATION CHART (CONTINUED)

(1) GROUP NUMBER	(2) COMPONENT/ ASSEMBLY	(3) MAINTENANCE FUNCTION	(4) MAINTENANCE LEVEL					(5) TOOLS AND EQUIPMENT	(6) REMARKS
			UNIT		DS	GS	DEPOT		
			C	O	F	H	D		
1143	Strainer	Inspect	0.3						
		Service	0.6						
		Replace	1.2						
1144	Drier	Inspect	0.2						
		Service	0.5						
		Replace	1.0						
1145	Gage Board	Inspect	0.3						
		Adjust	0.5						
		Replace	3.0						
		Repair	2.5						
1146	Thermal Expansion Valve	Inspect	0.2						
		Adjust	0.6						
		Replace	1.5						
		Repair	1.0						
1150	Miscellaneous Valves and Headers								
1151	Liquid Solenoid Valve	Inspect	0.5						
		Replace	1.0						
		Repair	2.0						
1152	Receiver	Inspect	0.5						
		Replace	1.0						
		Repair	1.0						
1153	Heat Interchanger	Inspect	0.5						
		Replace	3.0						
1154	Water Regulating Valve	Inspect	0.5						
		Service	0.5						
		Adjust	0.5						
		Replace	2.0						
1155	Thermometer	Inspect	0.5						
		Replace	0.5						

SECTION II. MAINTENANCE ALLOCATION CHART (CONTINUED)

(1) GROUP NUMBER	(2) COMPONENT/ ASSEMBLY	(3) MAINTENANCE FUNCTION	(4) MAINTENANCE LEVEL					(5) TOOLS AND EQUIPMENT	(6) REMARKS
			UNIT						
			C	O	F	H	D		
1156	Controller	Inspect Replace Repair	0.5 2.0 1.5						
1200	Commissary Space Equipment								
1210	Refrigerator/Freezer	Inspect Service Replace Repair	0.4 1.0 3.0		6.0 30.0 10.0				
1220	Toaster	Inspect Replace Repair	0.1 0.5 1.5						
1230	Drinking Fountain	Inspect Service Replace Repair	0.3 1.0 3.5 2.8						
1240	Milk Dispenser	Inspect Service Replace Repair	0.3 0.6 2.0 1.5		4.0 3.0				
1250	Coffee Maker	Inspect Replace Repair	0.1 0.5 1.5						
1260	Washer/Dryer	Inspect Service Replace Repair	2.0 0.3 2.0 2.5		10.0				
126001	Washer/Dryer Exterior	Inspect Repair	0.3 3.0						
126002	Washer/Dryer Drum Heater	Inspect Repair	0.5 3.0						
126003	Washer/Dryer Blower	Inspect Repair	0.4 1.5						

SECTION II. MAINTENANCE ALLOCATION CHART (CONTINUED)

(1) GROUP NUMBER	(2) COMPONENT/ ASSEMBLY	(3) MAINTENANCE FUNCTION	(4) MAINTENANCE LEVEL					(5) TOOLS AND EQUIPMENT	(6) REMARKS
			UNIT		DS	GS	DEPOT		
			C	O	F	H	D		
126004	Washer/Dryer Tubs, Water Valve and Lid Switch	Inspect Repair		1.0 4.0					
126005	Washer/Dryer Drive Pump System	Inspect Adjust Repair	0.5 0.5 2.5					K	
126006	Washer/Dryer Transmission, Water Seal and Lower Bearing	Inspect Replace Repair	0.5 2.0 5.0						
1270	Sanitizing Sink Heater	Inspect Replace Repair	0.2 3.0 2.0						
1280	Galley Range	Inspect Replace Repair	0.2 30.0 5.0						
1300	Washroom Fixtures	Inspect Replace Repair	0.2 1.5 1.0						
1400	Fire Fighting System	Overhaul				*		L	
1410	Fire Fighting Components	Inspect Test Replace	0.2 0.5 2.5						
1420	Halon Control Panel	Inspect Test Replace Repair	0.3 0.6 2.0 2.0						
1430	Pneumatic Heat Detector	Test Replace	0.5 1.0						
1440	Cylinder Assembly, 1301, 40 Pound	Inspect Test Service Replace	0.3 1.0 1.0 4.0						

SECTION II. MAINTENANCE ALLOCATION CHART (CONTINUED)

(1) GROUP NUMBER	(2) COMPONENT/ ASSEMBLY	(3) MAINTENANCE FUNCTION	(4) MAINTENANCE LEVEL					(5) TOOLS AND EQUIPMENT	(6) REMARKS
			UNIT		DS	GS	DEPOT		
			C	O	F	H	D		
1450	Cylinder Assembly, 1301, 60 Pound	Inspect	0.3						
		Test	1.0						
		Service	1.0						
		Replace	4.0						
1460	Halon System Piping and Wiring	Inspect	1.0						
		Test	2.0						
		Repair	6.0						
1500	Interior Communications System	Inspect	1.0						
		Service	2.0						
		Test	1.0						
		Replace			15.0				
		Repair	5.0		20.0			*	L
1510	Alarm Panel	Inspect	0.5						
		Test	1.0						
		Replace			30.0				
		Repair	5.0		20.0				
1600	Electronic(Navigation Systems	Inspect	1.0						
		Test	1.5						
		Replace			25.0				
		Repair	2.0		12.0			*	L
		Overhaul							
1610	VHF Antenna	Inspect	1.0						
		Replace			10.0				
		Repair			13.5				
1700	Oil/Water Separation System	Inspect	0.5						
		Service	1.5						
		Replace	20.0						
		Repair	2.0		13.5			*	L
		Overhaul							
1800	Piping Systems	Overhaul					*	L	

SECTION II. MAINTENANCE ALLOCATION CHART (CONTINUED)

(1) GROUP NUMBER	(2) COMPONENT/ ASSEMBLY	(3) MAINTENANCE FUNCTION	(4) MAINTENANCE LEVEL					(5) TOOLS AND EQUIPMENT	(6) REMARKS
			UNIT		DS	GS	DEPOT		
			C	O	F	H	D		
1801	Pipe Hangers	Inspect	1.0						
		Replace			15.0				
1810	Fire, Bilge and Ballast Piping System	Inspect	1.5						
		Replace			30.0				
		Repair	3.0		22.0				
1822	Machinery Cooling Keel Coolers	Inspect	1.0						
		Replace			25.0				
		Repair	2.0		18.0				
1830	Lube Oil Piping System	Inspect	1.0						
		Replace			20.0				
		Repair	2.0		18.0				
1832	Diesel Oil Storage Tank Piping System	Inspect	1.0						
		Replace			20.0				
		Repair	2.0		18.0				
1840	Diesel Oil Piping	Inspect	1.0						
		Replace			20.0				
		Repair	2.0		18.0				
1845	Diesel Oil Coolers	Inspect	1.0						
		Replace	1.5						
		Repair	1.5		10.0				
1846	Duplex Strainer	Inspect	0.5						
		Service	0.5						
		Replace	2.0						
		Repair	2.0						
1847	Fuel Fitters and Water Separator	Inspect	0.5						
		Service	0.5						
		Replace	1.5						
		Repair	2.0						
1850	Washdown Countermeasure Piping System	Inspect	1.0						
		Replace	20.0						
		Repair	2.0						

SECTION II. MAINTENANCE ALLOCATION CHART (CONTINUED)

(1) GROUP NUMBER	(2) COMPONENT/ ASSEMBLY	(3) MAINTENANCE FUNCTION	(4) MAINTENANCE LEVEL					(5) TOOLS AND EQUIPMENT	(6) REMARKS
			UNIT		DS	GS	DEPOT		
			C	O	F	H	D		
1870	Engine Exhaust Piping System	Inspect	1.0						
		Replace			20.0				
		Repair	2.0		18.0				
1890	Oil/Water Separator Piping	Inspect	1.0						
		Replace	1.0		20.0				
		Repair	2.0		18.0				
1895	Deck Fittings	Inspect	1.8						
		Replace			5.0				
		Repair	1.8		10.5				
1900	Tanks and Voids	Inspect	1.0						
		Replace			20.0				
		Repair	2.0		18.0				
		Overhaul					*	L	
1905	Receiver	Inspect	0.5						
		Test	0.5						
		Adjust	1.5						
		Replace			6.0				
		Repair	5.5		5.5				
1911	Transmitter	Inspect	0.5						
		Test	0.5						
		Replace	6.0						
1912	Cables	Inspect	1.0						
		Replace	4.5						
1913	Brackets	Inspect	1.0						
		Replace	4.5						
1914	Tank Penetrations	Inspect	0.5						
		Repair	4.5						
1915	Hot Water Heater	Inspect	0.5						
		Replace			20.0				
		Repair	5.0						

SECTION II. MAINTENANCE ALLOCATION CHART (CONTINUED)

(1) GROUP NUMBER	(2) COMPONENT/ ASSEMBLY	(3) MAINTENANCE FUNCTION	(4) MAINTENANCE LEVEL					(5) TOOLS AND EQUIPMENT	(6) REMARKS
			UNIT		DS	GS	DEPOT		
			C	O	F	H	D		
2000	Plumbing and Deck Drains	Inspect	1.0						
		Replace			8.0				
		Repair Overhaul	2.0				*	L	
2100	Vents and Sounding Tubes	Inspect	1.2						
		Replace			10.5				
		Repair Overhaul	2.5				*	L	
2200	Hull and Outfit	Overhaul					*	L	
2210	Stanchions and Railings	Inspect	1.2						
		Replace	22.0						
2213	Furniture and Misc. Furnishings	Inspect,	1.8						
		Replace	2.5		7.5				
2214	Portable Air Compressor	Inspect	0.5						
		Replace	1.0						
		Repair	2.5						
2215	Doors, Hatches, Scuttles and Manholes	Inspect	2.0						
		Replace	8.0		15.0				
		Repair	4.0		15.0				
2216	Windows and Airports	Inspect	1.5						
		Replace	10.0						
		Repair	3.0						
2217	Mooring and Towing Fittings	Inspect	1.0						
		Replace	12.0						
2218	High Intensity Lights	Inspect	1.0						
		Test	0.5						
		Replace	2.0						
		Repair	3.5						

SECTION II. MAINTENANCE ALLOCATION CHART (CONTINUED)

(1) GROUP NUMBER	(2) COMPONENT/ ASSEMBLY	(3) MAINTENANCE FUNCTION	(4) MAINTENANCE LEVEL					(5) TOOLS AND EQUIPMENT	(6) REMARKS
			UNIT		DS	GS	DEPOT		
			C	O	F	H	D		
2219	Windshield Wipers	Inspect	0.8						
		Test	0.8						
		Replace	5.0						
		Repair	3.0						
2220	Searchlight	Inspect	0.2						
		Service	0.7						
		Repair	2.5						
		Replace	1.5						
2221	Vehicle Lashing Gear	Inspect	1.0						
		Replace	4.5						
		Repair	6.5						
2222	Air Horn System	Inspect	0.5						
		Test	0.2						
		Replace	3.0						
		Repair	4.0						
222201	Air Horn Piping	Inspect	1.0						
		Test	1.0						
		Repair	4.0						
222202	Air Horn	Inspect	0.2						
		Test	0.2						
		Replace	1.0						
		Repair	1.5						
222203	Whistle Valve	Test	0.2						
		Replace	1.5						
		Repair	1.0						
222204	Air Strainer Assembly	Service	0.3						
		Replace	1.0						
222205	Air Compressor Unit	Inspect	0.3						
		Replace	4.0						
		Repair	8.0						
22220501	Air Compressor	Replace	2.0						
		Repair	8.0						

SECTION III. TOOL AND TEST EQUIPMENT REQUIREMENTS

TOOL OR TEST EQUIPMENT REF CODE	MAINTENANCE CATEGORY	NOMENCLATURE	NATIONAL/NATO STOCK NUMBER	TOOL NUMBER
1	C, H	Gage, Compression	6220-01-065-3441	J4897-5 (33287)
2	C, H	Adapter, Compression Gage	5210-00-999-8777	J7915-02 (33287)
3	C, H	Gage, Governor Gap (.200)	5210-01-048-7085	J23478 (33287)
4	C, H	Gage, Governor Gap (.001 5)	5210-01-048-6532	J23185 (33287)
5	C, H	Gage, Governor Linkage	5210-00-125-4415	J21304(33287)
6	C, H	Wrench, Governor High Speed	5120-00-627-9311	J1652-01 (33287)
7	C, H	Clamp Set, Alignment		J21834-01(33287)
8	C, H	Cam Installer, Blower Drive	5120-00-219-8405	J1471(33287)
9	C, H	Tool Set, Blower Service	4940-00-611-7945	J6270-04(33287)
10	C, H	Tool Set, Fuel Pump		J1508-02(33287)
11	C, H	Wrench, Fuel & Water Pump	5120-00-591-2685	J4242(33287)
12	H	Reamer, Injector Body	5110-00-937-7628	J21089(33287)
13	H	Service Set, Injector	5220-00-483-1375	J23435(33287)
14	C, H	Timing Gage, Injector 1.484	5210-00-474-6400	J1242(33287)
15	H	Lapping Block Set, Injector	3460-00-937-5521	J22090(33287)
16	C, H	Installer, Water Pump Oil Seal	5120-01-012-9151	J22150(33287)
17	C, H	Installer, Water Pump Seal	5120-00-937-7267	J8501(33287)
18	C, H	Remover, Water Pump Coupling and Oil Seal	5120-00-363-7572	J1930(33287)
19	C, H	Remover, Water Pump Impeller	2040-01-057-6267	J22143(33287)
20	C, H	Installer, Flywheel Housing Oil Seal	5120-00-999-8619	J9727(33287)

SECTION III. TOOL AND TEST EQUIPMENT REQUIREMENTS

TOOL OR TEST EQUIPMENT REF CODE	MAINTENANCE CATEGORY	NOMENCLATURE	NATIONAL/NATO STOCK NUMBER	TOOL NUMBER
21	C, H	Puller, Crankshaft Pulley	5120-00-671-4494	J4558-01 (33287)
22	C, H	Lifter, Flywheel	4910-00-722-3877	J6361-01 (33287)
23	C, H	Puller, Camshaft Gear	5120-00-219-8397	J1902-01 (33287)
24	C, H	Installer, Camshaft Gear	5120-00-473-7456	J1903 (33287)
25	C, H	Service Fixture, Camfollower	2815-00-705-9278	J5840-01 (33287)
26	C, H	Remover Set, Push Rod	5120-00-494-1843	J3092-01 (33287)
27	C, H	Wrench, Cylinder Head	5120-01-013-1677	J1928-01 (33287)
28	C, H	Wrench, Torque, 112" Drive, 0-300 Ft. Lbs.	5120-00-247-2536	GGG-W-00686 (81348)
29	H	Reconditioning Kit, Injector Tube	2910-00-146-9619	J22525 (33287)
30	C, H	Remover, Valve Seat Insert	5120-00-999-8613	J6567-02 (33287)
31	C, H	Installer, Valve Seat Insert	5120-00-733-8876	K6568 (33287)
32	C, H	Compressor, Valve Spring	5210-00-733-8888	J7455 (33287)
33	C, H	Lifting Fixture, Cylinder Head	4910-00-432-7620	J22062-01 33287)
34	C, H	Stud Set, Guide	4910-00-591 -6634	J9665 (33287)
35	C, H	Installer, Oil Pump Drive Gear		J22285(33287)
36	C, H	Installer, Oil Pump Gear	5120-00-937-7268	J8509 (33287)
37	C, H	Reamer Set, Connecting Rod Bushing	4910-00-733-8896	J1686-03 (33287)
38	C, H	Remover, Connecting Rod Nozzle	5120-00-937-7632	J8995 (33287)

SECTION III. TOOL AND TEST EQUIPMENT REQUIREMENTS

TOOL OR TEST EQUIPMENT REF CODE	MAINTENANCE CATEGORY	NOMENCLATURE	NATIONAL/NATO STOCK NUMBER	TOOL NUMBER
39	C, H	Hold-down Clamp, Cylinder Liner	5120-00-219-8394	J21793-01(33287)
40	C, H	Remover, Cylinder Liner	5120-00-387-9615	J1918-02 (33287)
41	C, H	Gage, Cylinder Diameter Checking	5210-01-070-4543	J5347-01 (33287)
42	C, H	Installer and Remover Set, Piston and Connecting Rod Bushing	5180-00-776-7240	J1513-02 (33287)
43	C, H	Reaming Fixture, Piston Bushing	4910-00-779-6163	J5273 (33287)
44	C, H	Assembly Tool, Piston Ring	5120-00-494-1846	J8128 (33287)
45	C, H	Compressor, Piston Ring	5120-00-859-6259	J3272-03 (33287)
46	C, H	Gage, Master Ring	5120-00-937-7631	J8386-01 (33287)
47	C, H	Installer, Crankshaft Oil Seal, Front	5120-00-936-4377	J9783 (33287)
48	C, H	Tool, Shaft Seal Aligning		52407(58849)
49	C, H	Remover and Installer Set, Blower Rotor Shaft	5120-00-113-1004	J4254(33287)
50	C, H	Gage, Injector Timing (1.460)	5220-00-387-9851	J1853 (33287)
51	C, H	Installer, Water pump Seal	2815-00-018-2631	J21971 (33287)
52	C, H	Reconditioning Set, Lube Oil	5180-00-113-3168	J2624 (33287)
53	C, H	Wrench, Torque, 3/4" Drive	5120-00-221-7983	

SECTION IV. REMARKS

REFERENCE CODE	REMARKS
A	All tools required for repair/overhaul of Twin Disc marine gear to be made locally in accordance with instructions contained in technical manual for MG514 Marine Gear DM-133.
B	Used only on Detroit Diesel Hydraulic Starting System.
C	Used only on American Bosch Hydraulic Starting System.
D	Use Compound (P/N 5198653) (72582) when reassembling fresh water pump.
E	Adhere to drawing 203-4661553 when disassembling propeller shafts.
F	Propellers and propeller shaft will be carried on board even though the maintenance level is not crew/operator, to give the craft the "Get home" capability.
G	General Support units will not attempt in-depth repair of Gyro Compasses. Report them to the National Maintenance Point (NMP).
H	No Field repair is authorized on the Remote Magnetic Heading System (RMHS). Report them to the National Maintenance Point (NMP).
I	Refer to TM 5-2815-251-14, Detroit Diesel Engines, V-71, Section 1.4.
J	Replacement of Fuse Cartridge.
K	Drive Belt Adjustment.
L	Depot Level Repair/Maintenance will be performed on a case by case basis, subject to approval and funding by the National Maintenance Point (NMP).

Change 5 B-44

APPENDIX C
COMPONENTS OF END ITEMS AND
BASIC ISSUE ITEMS LISTS.
SECTION I. INTRODUCTION.

C-1. SCOPE

This appendix lists components of end item and basic issue items for the Landing Craft to help you inventory items required for safe and efficient operation.

C-2. GENERAL

The Components of End Item and Basic Issue Items Lists are divided into the following sections:

a. Section II. Components of End Item. This listing is for informational purposes only, and is not authority to requisition replacements. These items are part of the end item, but are removed and separately packaged for transportation or shipment. As part of the end item, these items must be with the end item whenever it is issued or transferred between property accounts. Illustrations are furnished to assist you in identifying the items.

b. Section III. Basic Issue Items. These are the minimum essential items required to place the Landing Craft in operation, to operate it, and to perform emergency repairs. Although shipped separately packaged BII must be with the Landing Craft during operation and whenever it is transferred between property accounts. The illustrations will assist you with hard-to-identify items. This manual is your authority to request/requisition replacement BII, based on TOE/ MTOE authorization of the end item.

C-3. EXPLANATION OF COLUMNS

The following provides an explanation of columns found in the tabular listings:

a. Column (1) - Illustration Number (Illus Number). This column indicates the number of the illustration in which the item is shown.

b. Column (2) - National Stock Number. Indicates the National stock number assigned to the item and will be used for requisitioning purposes.

c. Column (3) - Description. Indicates the National item name and, if required, a minimum description to identify and locate the item. The last line for each item indicates the FSCM (in parentheses) followed by the part number.

SECTION I. INTRODUCTION (CONTINUED).

d. Column (4) - Unit of Measure (U/M). Indicates the measure used in performing the actual operational/maintenance function. This measure is expressed by a two-character alphabetical abbreviation (e.g., ea, in, pr).

e. Column (5) - Quantity required (Qty rqr). Indicates the quantity of the item authorized to be used with/on the equipment.

SECTION II. COMPONENTS OF END ITEMS LIST

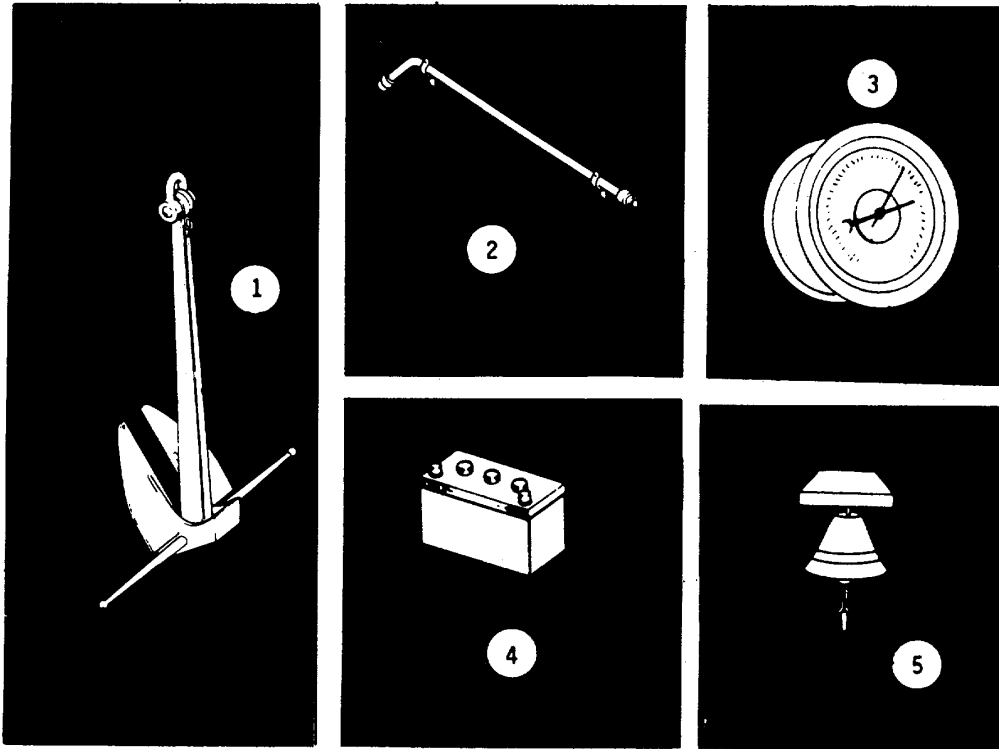

(1) ILLUS NO.	(2) NATIONAL STOCK NUMBER	(3) DESCRIPTION FSCM AND PART NUMBER	USABLE ON CODE	(4) U/M	(5) QTY RQR
1	2040-00-377-8607	Anchor, Marine, Fluked, 15500 lb (81349) MIL-A- 15707		EA	2
2	4210-00-372-0864	Applicator, Nozzle, Fog, 4 (81348) MIL-S-1070		EA	3
3	6660-00-075-6666	Barometer, Aneroid (81349) MIL-B-17896B		EA	1
4	6140-00-105-5341	Battery, Storage, 6V 100AH (81348) W-B-131		EA	4
5	6350-00-256-9062	Bell, Ships 30 lb. "A" flat (81349) MIL-B-674		EA	1

SECTION II. COMPONENTS OF END ITEMS LIST (CONTINUED).

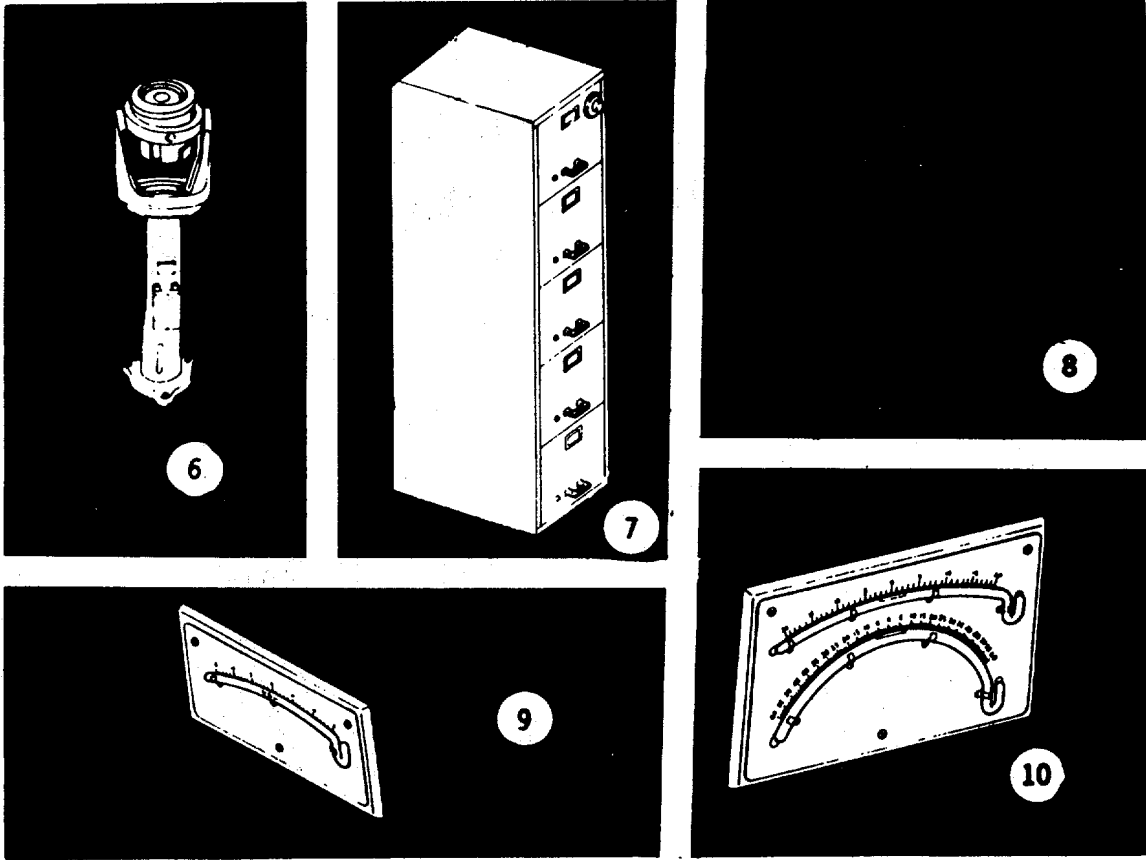

(1) ILLUS NO.	(2) NATIONAL STOCK NUMBER	(3) DESCRIPTION FSCM AND PART NUMBER	(4) USABLE ON CODE U/M	(5) QTY RQR
6	6605-00-530-0459	Binnacle Assembly (03956) 1887627	EA	1
7		Cabinet, filing 4 drawer W/combo lock (80064) 805-163842	EA	1
8		Cable, Shore Power, W/lugs, THOF-15 (81349) MIL-C-915	FT	75
9	6605-00-618-3887	Clinometer, Ship's Heel (81349) MIL-C-200061, Type II	EA	1
10		Clinometer, Ship, Trim (81349) MIL-C-200061, Type 1	EA	1

SECTION II. COMPONENTS OF END ITEMS LIST(CONTINUED).

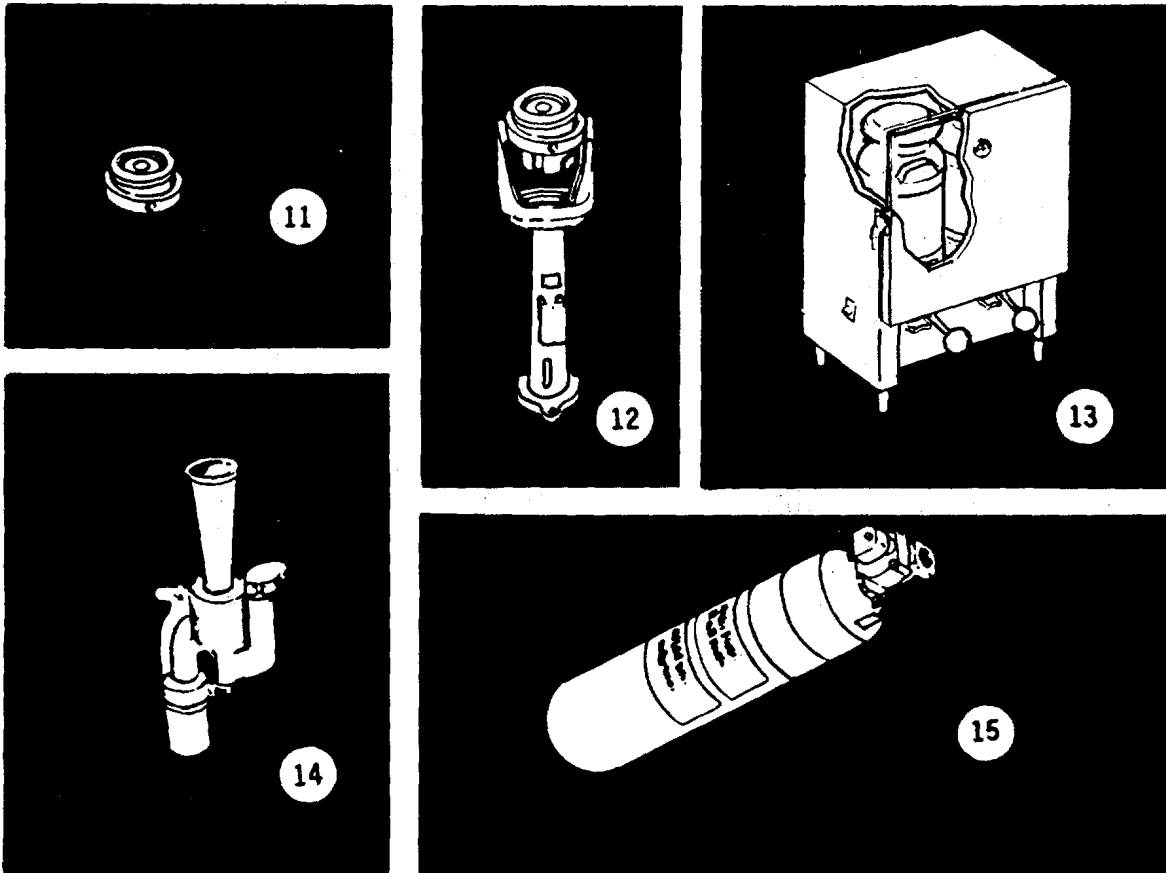

(1) ILLUS NO.	(2) NATIONAL STOCK NUMBER	(3) DESCRIPTION FSCM AND PART NUMBER	USABLE ON CODE	(4) U/M	(5) QTY RQR
11	6605-00-248-0595	Compass Magnetic (80064) Navy No. 3 S2407A533821		EA	1
12	6605-00-019-0481	Compass, Gyro, MK27, MOD 1, W/70DVC Step by step, 1X & 36X 40OHZ transmission		EA	1
13	7310-00-345-9903	Dispenser, Milk, refrigerated 10 gal (21880) NIOM		EA	1
14	4320-00-256-8206	Eductor 4 inch (71905) 485011		EA	1
15	4210-00-203-0341	Extinguisher, fire, fixed 50 lb (33333) NO REF		EA	1

SECTION II. COMPONENTS OF END ITEMS LIST (CONTINUED).

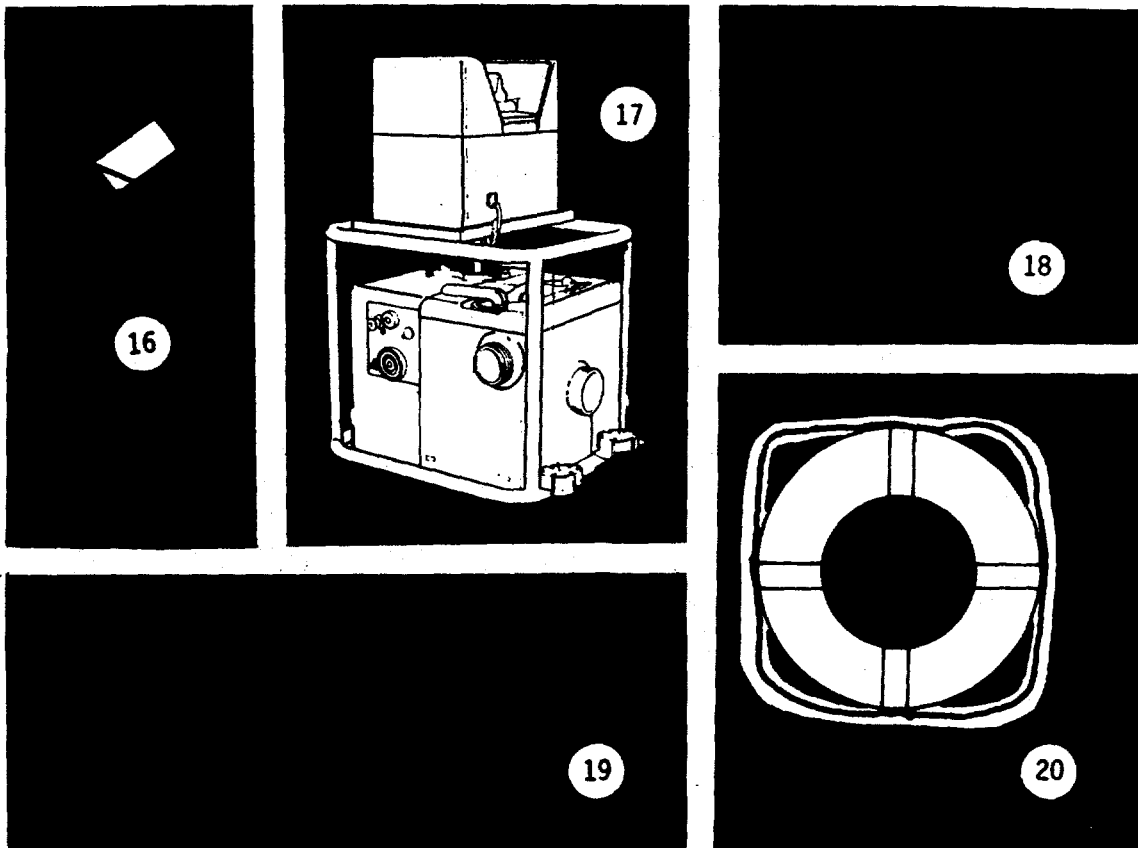

(1) ILLUS NO.	(2) NATIONAL STOCK NUMBER	(3) DESCRIPTION FSCM AND PART NUMBER	(4) USABLE ON CODE U/M	(5) QTY RQR
16	4210-00-558-8837	Extinguisher, fire, Portable 20 lb (81349) MIL-E-24091	EA	12
17	2040-00-565-9124	Fender Marine (81349) MIL-F-58065	EA	14
18	4210-00-078-9170	Hose, Fire, 1 1/2 inch NH x 50 feet long (33333) NO REF	EA	6
19	6230-00-828-6398	Lantern, Elcl, 6V. w/relay Lantern Elcl. 6V (33333) NO REF	EA	1
20	1940-00-204-3894	Life Raft, Inflatable (81349) MIL 19496	EA	2
21	4210-00-288-6857	Nozzle, Fire, 3 position 1 1/2 inch Type 1 Class C (81349) MIL-N-12276	EA	5

SECTION II. COMPONENTS OF END ITEM LIST (CONTINUED)

(1) ILLUS NUMBER	(2) NATIONAL STOCK NUMBER	(3) DESCRIPTION CAGEC AND PART NUMBER	(4) USABLE U/I ON CODE	(5) QTY RQR
The following listed items comprise the installed communication/electronic equipment.				
22	5895-00-879-0211	IFF, RT-859/APC 72	EA	1
23	5840-01-017-2798 7H422	Radar Set, AN/SPS-69, Model R41 X	EA	1
24	5840-01-017-3024	Radar Antenna, AS-3146/SPS-59(V)	EA	1
25	5840-01-017-2684	Radar Display Unit, IP-1258/SPS-59(V)	EA	1
26	5810-00-110-8617	Transceiver, RT-1061/URC-80(V)	EA	1
27	5820-00-164-2146	Control, Receiver Trans, C-8981/URC-80(V)	EA	1
28	5820-01-057-6447	Radio Set, AN/URC 92	EA	1
29	5820-00-223-7433	Radio Set, AN/URC 46	EA	1
30	5820-00-906-1115	Antenna, MX-6707 VRC	EA	1
31		Antenna, 6035-0000 SSB 92	EA	1
32	5820-00-538-7555	Receiver, R390-URR	EA	1
33		Amplifier, AM6747 GR	EA	1
		Omni - Directional Antenna System, MK22CA/Pba 2205 (OGMC3)	EA	1
		Marinefax, TR-IV, Model 9414 (04855)	EA	1
		Antenna, Receiving, DA100D (32172)	EA	1
		Aerovane Wind Indicator/Transmitter, Model 120 (Trans), Model 135 (Ind) (82205)	EA	1
		Emergency Lifeboat Transceiver, 403A (OTFK2)	EA	1
		EPIRB, SATFIND-406, M3 (04855)	EA	1
		CONVERTER, DC-DC, Heavy Duty, Model 32-12-10, 420-0327-0 (62028)	EA	1

SECTION II. COMPONENTS OF END ITEM LIST (CONTINUED)

(1) ILLUS NUMBER	(2) NATIONAL STOCK NUMBER	(3) DESCRIPTION CAGEC AND PART NUMBER	(4) USABLE ON CODE	(5) U/I QTY RQR
		Antenna Coupler, Digital Automatic, DCU-100 (12338)	EA	1
		Transceiver, Marine, VHF, DSC 500 (OWF67)	EA	1
		Radio, Portable, EPH/EPI (22373)	EA	4
		Charger, Battery, LAA0300 Series (22373)	EA	1
		Television, Color Recorder, Video Cassette, VHS	EA EA	1 1

SECTION III. BASIC ISSUE ITEMS LIST.

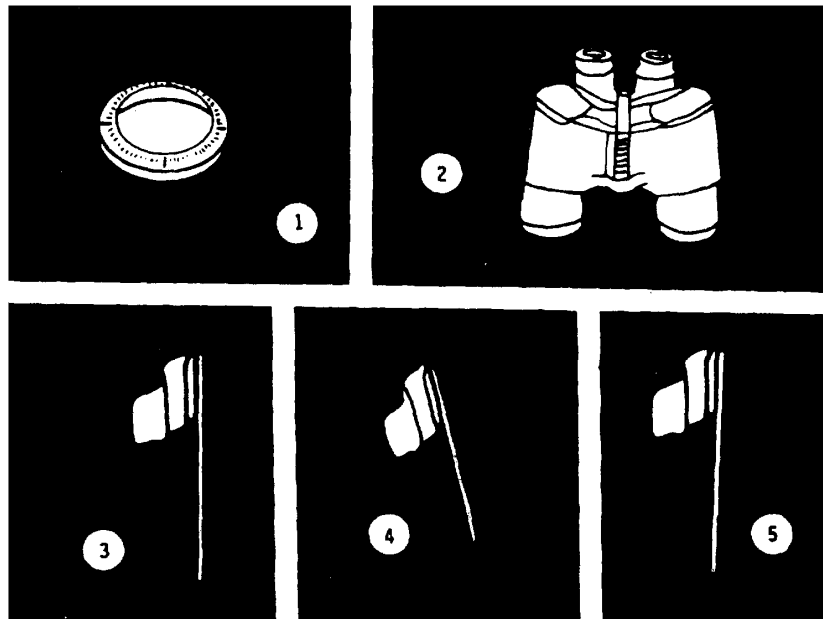

(1) ILLUS NUMBER	(2) NATIONAL STOCK NUMBER	(3) DESCRIPTION CAGEC AND PART NUMBER	(4) USABLE U/I ON CODE	(5) QTY RQR
1	6605-00-9194743	Azimuth Circle, 6 inches MK4, MOD 1 (80064) 00-533-991	EA	1
2	6605-00-530-0974	Binocular, 7 X 50, M17A1 (81349) MIL-B-76566	EA	3
3	8345-00-656-1446	Flag, National, Union Jack, 1 foot 10 inches X 2 feet 8 inches (81348) DDD-F-416	EA	2
4	8345-00-245-2040	Flag, National, U. S., 1 foot 6 inches X 2 feet 2 inches (81348) DDD-F-416	EA	2
5	8345-00-935-3120	Flag, Organizational, Transportation Corps (81348) DDD-F-416	EA	2

SECTION III. BASIC ISSUE ITEMS LIST (CONTINUED).

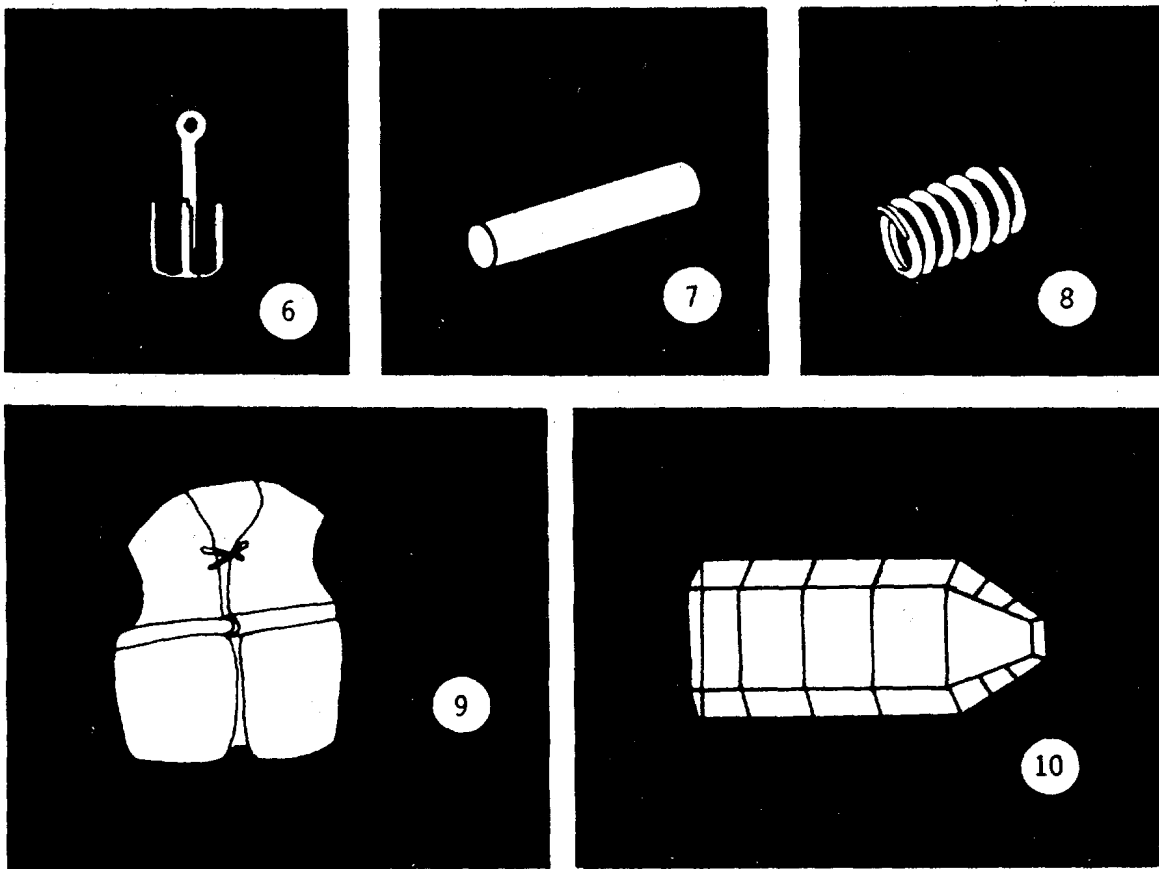

(1) ILLUS NO.	(2) NATIONAL STOCK NUMBER	(3) DESCRIPTION FSCM AND PART NUMBER	(4) USABLE ON CODE U/M	(5) QTY RQR
6	2040-00-238-9060	Grapnel, Marine, 5 Prong	EA	1
7	4720-00-288-8532	Hose Assy, 1 1/2 inches X 50 inches (F.W.F. 11)	EA	2
8	4720-00-202-6482	Hose Assy, Rubber Wrapped, Water 3/4 inch	EA	2
9	4220-00-200-0538	Life Preserver, Vest (81349) MIL-L-18045	EA	16
10	6530-00-785-7810	Litter, Rigid, Stokes	EA	1

SECTION III. BASIC ISSUE ITEMS LIST (CONTINUED).

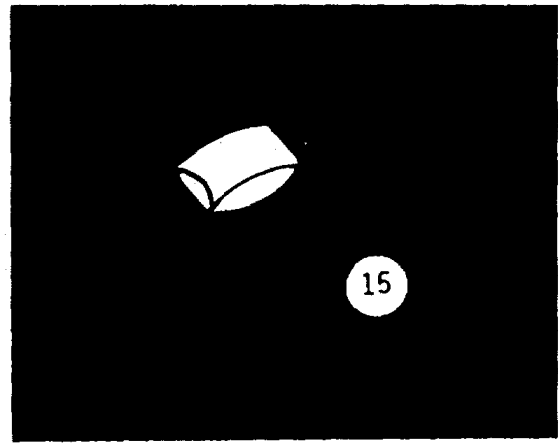
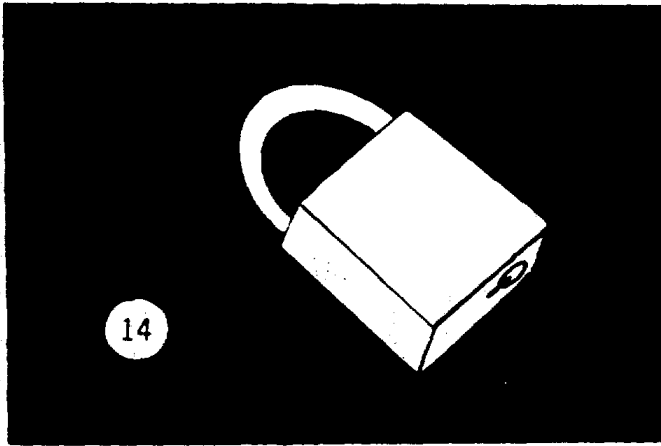
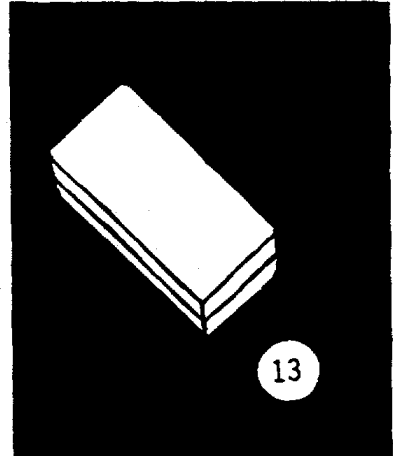
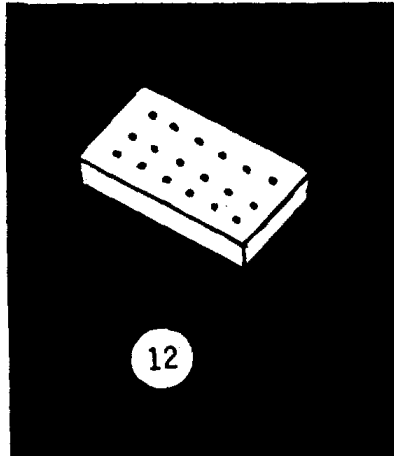
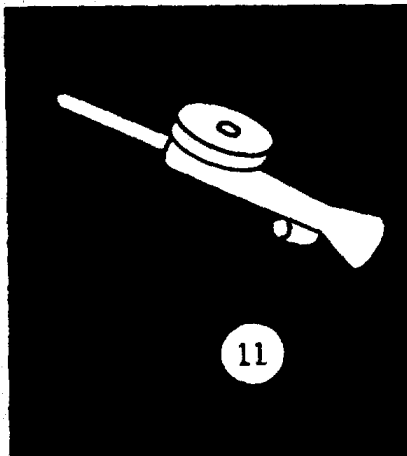

(1) ILLUS NO.	(2) NATIONAL STOCK NUMBER	(3) DESCRIPTION FSCM AND PART NUMBER	(4) USABLE ON CODE U/M	(5) QTY RQR
11		Line Throwing Device (75324) GR-52-A2	EA	1
12	7210-00-935-6619	Mattress, Bed	EA	12
13	7210-00-205-3585	Mattress, Bed Box Spring Combination	EA	2
14	5340-00-582-2742	Padlock, Keyed (96906) MS35647-1	EA	48
15	7210-00-292-2326	Pillow Bed (81348) V-P-356	EA	14

SECTION III. BASIC ISSUE ITEMS LIST (CONTINUED).

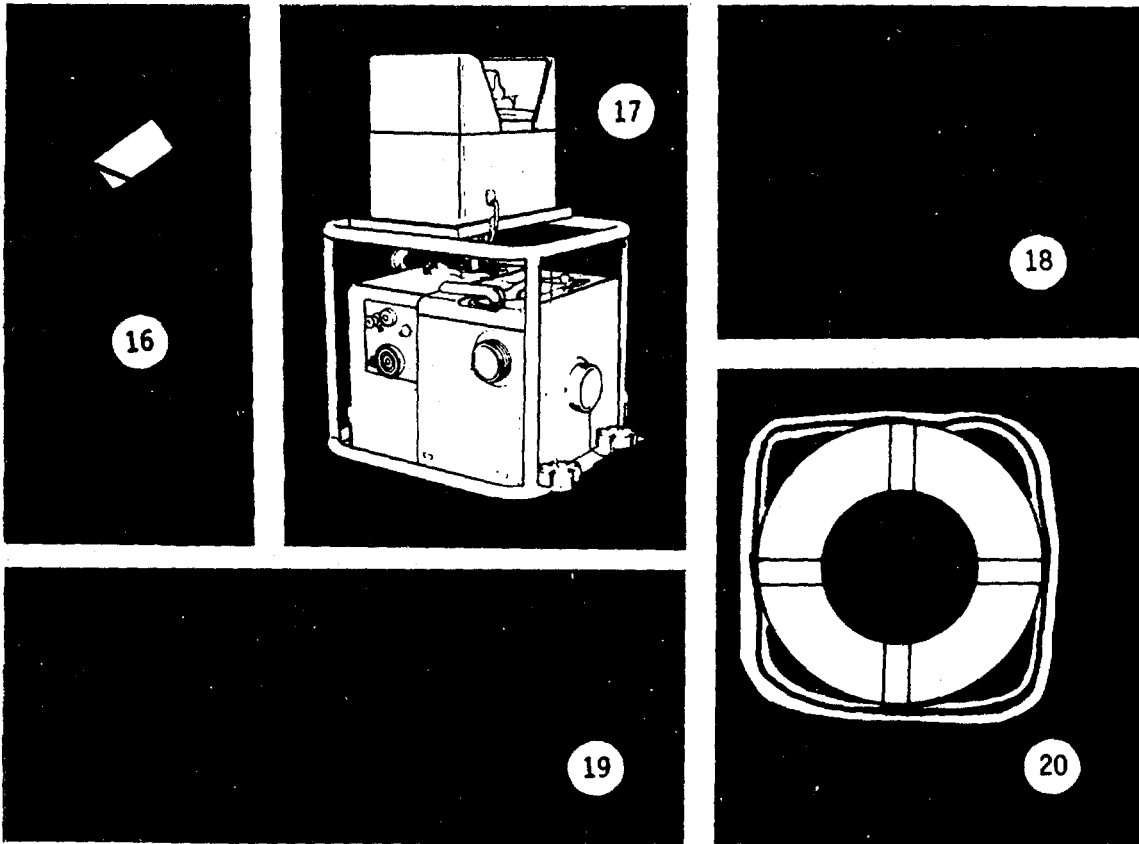

(1) ILLUS NO.	(2) NATIONAL STOCK NUMBER	(3) DESCRIPTION FSCM AND PART NUMBER	(4) USABLE ON CODE U/M	(5) QTY RQR
16	7210-00-292-2326	Pillowcase, Bed (81348) DDD-P-381	EA	28
17	4320-00-368-4419	Pump, Centrifugal, Portable (Fire & Salvage) (80256) 553144	EA	1
18	4930-00-263-9886	Pump Dispensing Hand Rotary (81349) MIL-D-40078, Type 1, Class 1	EA	2
19		Pump, Submersible, Elcl (39428) 4327K2	EA	1
20	4220-00-275-3157	Ring, Buoy, Floating, 30 inches (81349) MIL-R-116847	EA	6

SECTION III. BASIC ISSUE ITEMS LIST (CONTINUED).

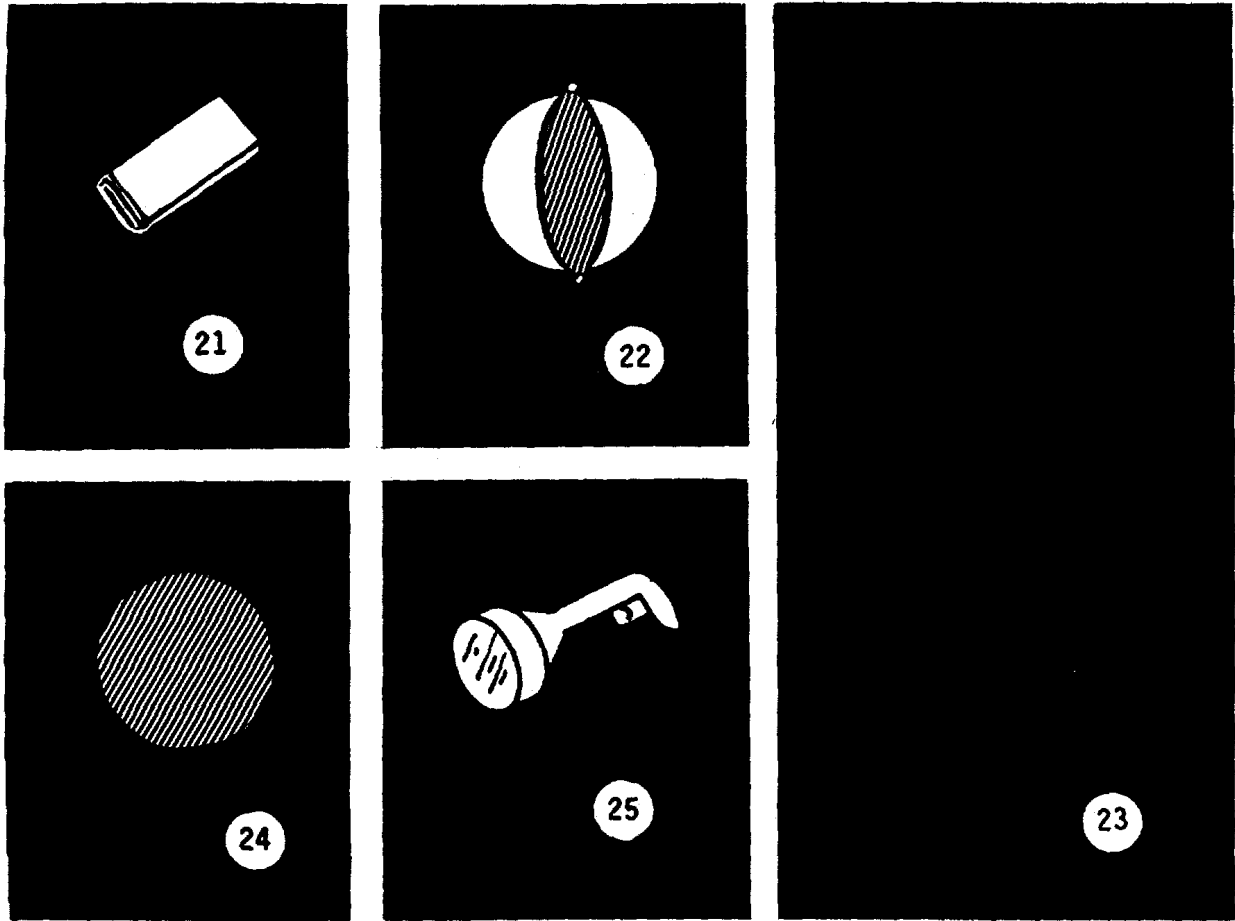

(1) ILLUS NO.	(2) NATIONAL STOCK NUMBER	(3) DESCRIPTION FSCM AND PART NUMBER	(4) USABLE ON CODE U/M	(5) QTY RQR
21	7210-00-171-1099	Sheet, Bed DDD-S-281	EA	56
22	8345-00-264-6081	Signal, Day, Maritime, Ball, Black & White (81349) MIL-S-29108	EA	1
23	4320-01-029-9675	Pump, Centrifugal, Portable (PE250)0 (52845) When uneconomical to repair, requisition.		
24	8345-00-276-9576	Signal, Day, Maritime, Ball, Red (81349) MIL-S-29108	EA	1
25	5850-00-407-6771	Signal, Lamp ALDIS (80063) SE11	EA	1

SECTION III. BASIC ISSUE ITEMS LIST (CONTINUED).

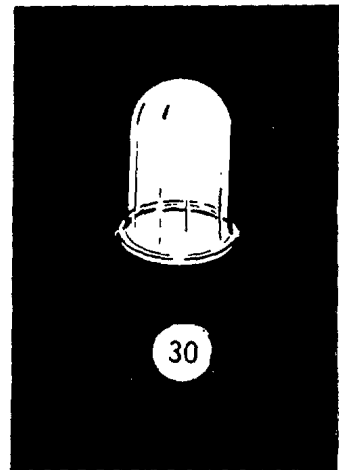
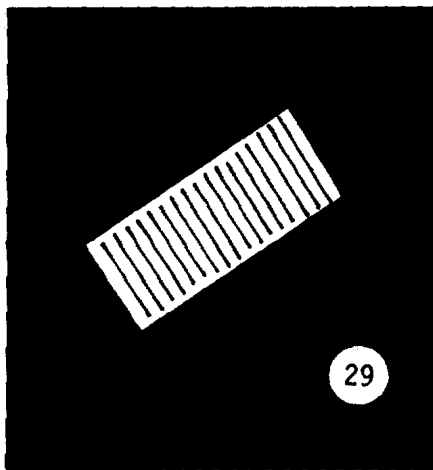
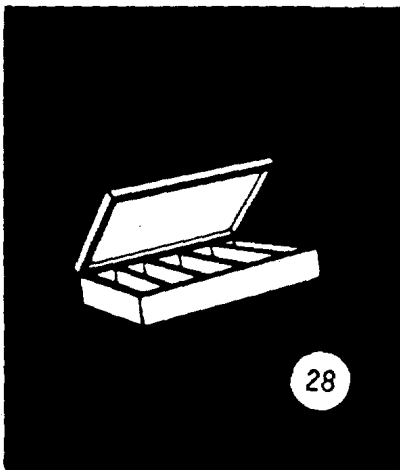
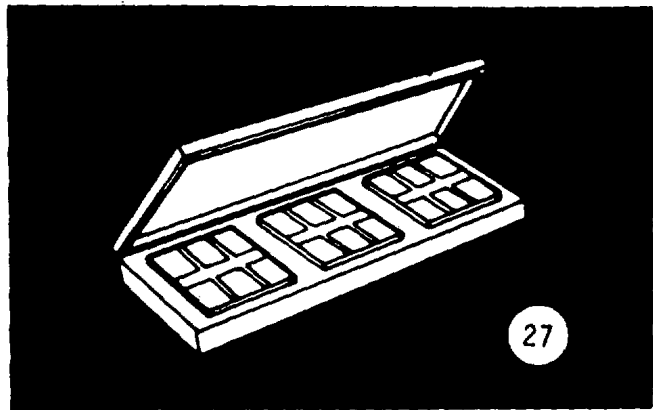
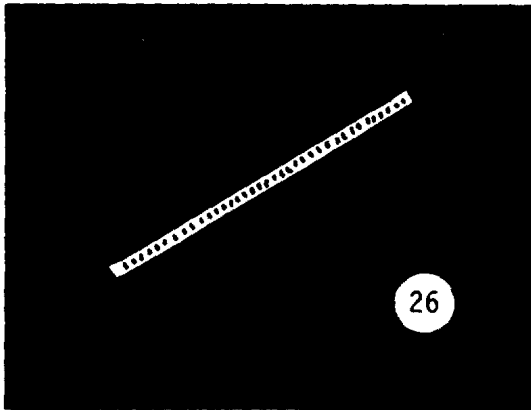

(1) ILLUS NO.	(2) NATIONAL STOCK NUMBER	(3) DESCRIPTION FSCM AND PART NUMBER	(4) USABLE ON CODE U/M	(5) QTY RQR
26	5210-00-526-0752	Tape, Tank MEASURING, 50 feet (37163) 14075	EA	1
27	6630-00-316-5831	Test Kit, Chromate (71821) 121358	EA	1
28	6630-00-531-1931	Test Kit, 0.1 Condition (81349 MIL-T-19467	EA	1
29	7220-01-024-9041	Mat, Floor, Synthetic (81349) MIL-M-15562 Type	YD	10
30	6220-00-2909-7146	Lens, Marine, Green Navigational (46576) 259-1-G	EA	1

SECTION III. BASIC ISSUE ITEMS LIST (CONTINUED).

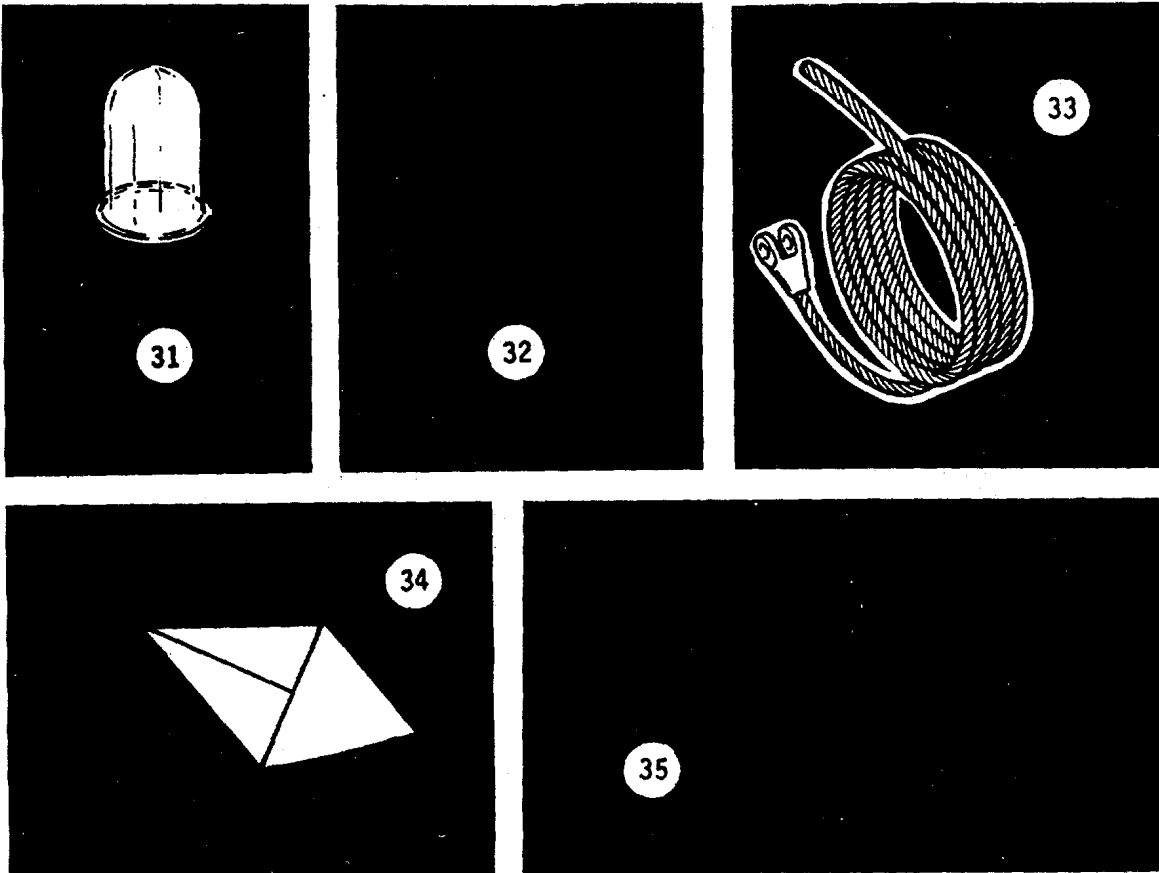

(1) ILLUS NO.	(2) NATIONAL STOCK NUMBER	(3) DESCRIPTION FSCM AND PART NUMBER	(4) USABLE ON CODE U/M	(5) QTY RQR
31	6220-00-299-7151	Lens, Marine, Red, Navigational (46576)	EA	1
32	4310-00-289-5967	Pump, Vacuum (to pull vacuum on Air Conditioning and Refrigeration Systems)	EA	1
33	4010-00-436-4276	Wire, Rope, Steel, Zinc Coated Breaking Strength 132,000 Lbs. 900 feet Required RR-W-06410, Type 1, Class 3, Construction 4	FT	900
34	2040-00-222-3729	Anchor, Sea, 36 x 70 (81348) MM-1-562	EA	1
35	4210-00-372-0864	Applicator, Nozzle, Fog 4 feet	EA	4

SECTION III. BASIC ISSUE ITEMS LIST (CONTINUED))

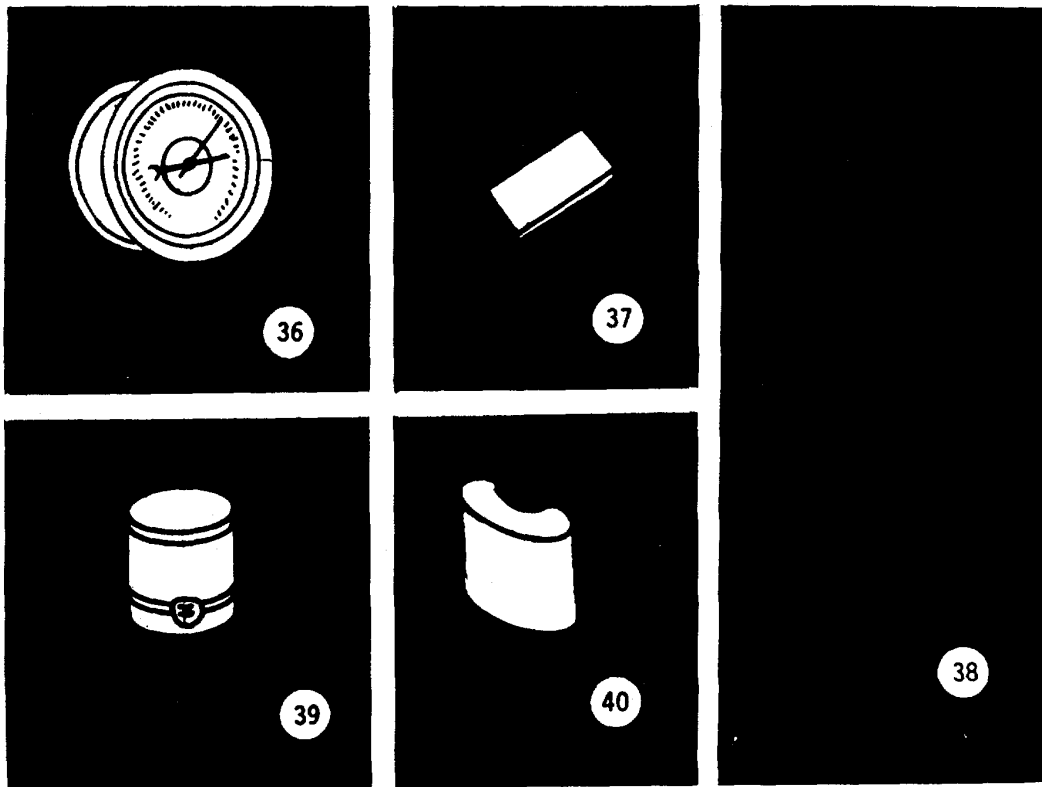

(1) ILLUS NO.	(2) NATIONAL STOCK NUMBER	(3) DESCRIPTION FSCM AND PART NUMBER	USABLE ON CODE	(4) U/M	(5) QTY RQR
36	6685-00-537-9173	Barometer, Aneroid (80063) P/N 3257A		EA	1
37	6545-00-911-1300	Blanket Set, Medical		EA	1
38	4240-00-678-5263	Breathing Apparatus, Oxygen (81349) B-51254		EA	4
39	7240-00-256-7700	Can, Flammable Waste, 5 Gallon (81349) RR-C-114		EA	2
40	4240-00-174-1365	Canister, OBA (81349) C-17671		EA	4

SECTION III. BASIC ISSUE ITEMS LIST (CONTINUED))

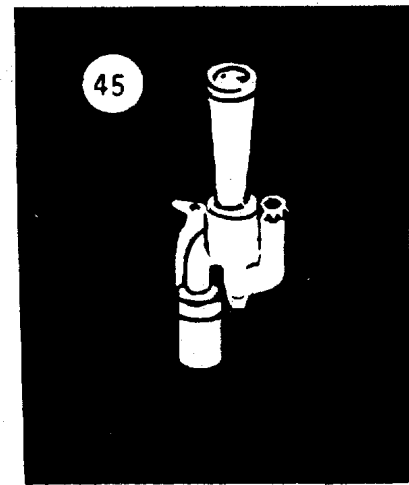
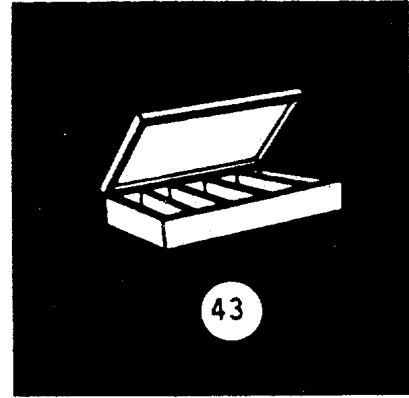
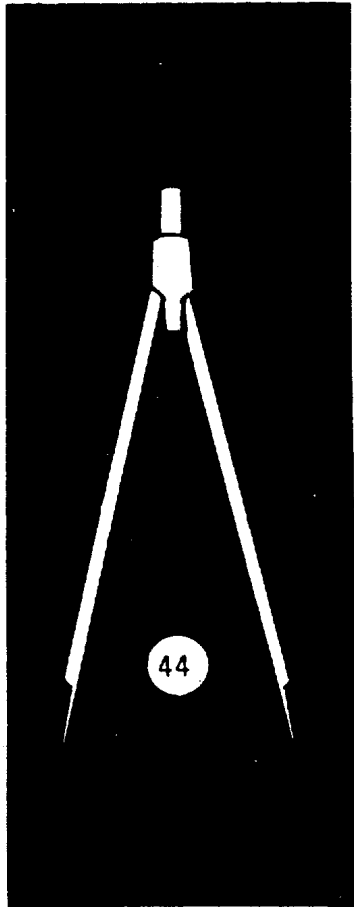
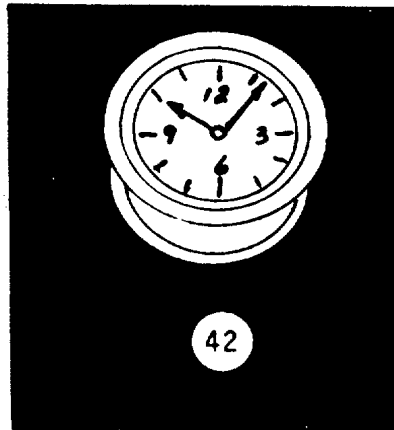
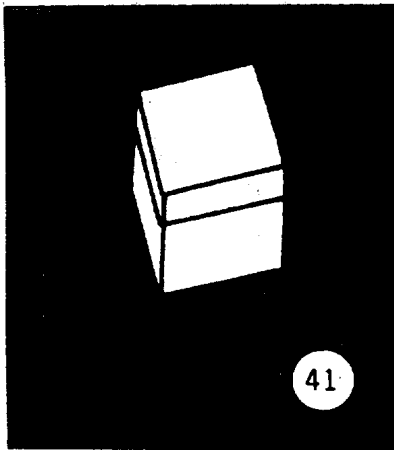

(1) ILLUS NO.	(2) NATIONAL STOCK NUMBER	(3) DESCRIPTION FSCM AND PART NUMBER	(4) USABLE ON CODE U/M	(5) QTY RQR
41	6645-00-290-2233	Case, Chronometer, u/w Size 35	EA	1
42	6645-00-238-9054	Chronometer, Size 35 (81348) C-2536	EA	1
43	6665-00-903-4767	Detector Kit, Chemical Agent	EA	1
44	6605-00-025-7005	Divider Set, Navigation (80064) S2407H533623	EA	1
45		Eductor, Bilge, 2 x 3 (71905) 358	EA	1

SECTION III. BASIC ISSUE ITEMS LIST (CONTINUED))

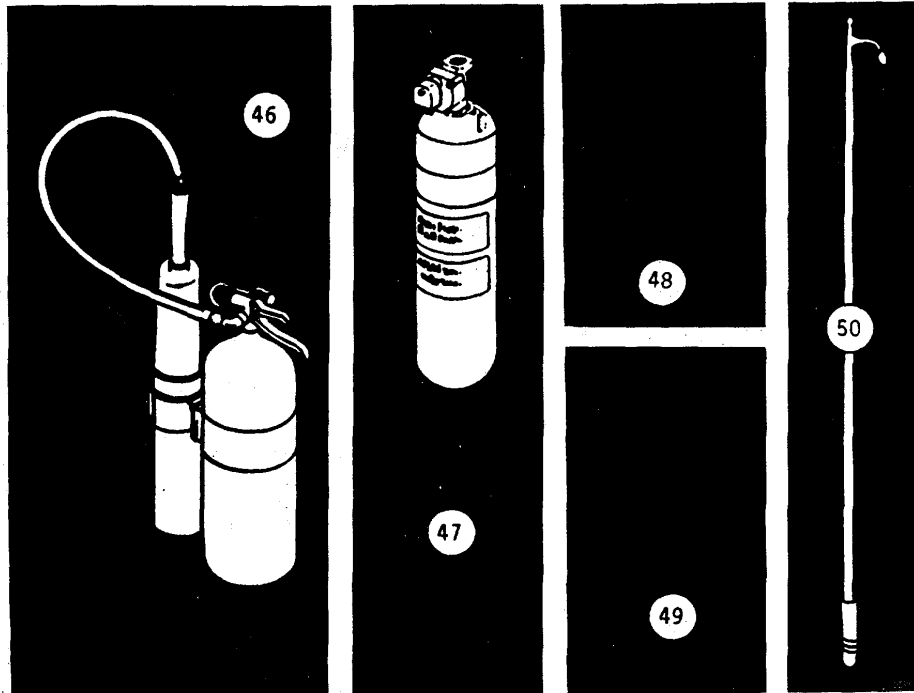

(1) ILLUS NO.	(2) NATIONAL STOCK NUMBER	(3) DESCRIPTION FSCM AND PART NUMBER	(4) USABLE ON CODE U/M	(5) QTY RQR
46	4210-00-555-8837	Extinguisher, Fire, Halon, 15 lb, portable (81348) E810, Type 1, Size 15	EA	12
47		Extinguisher, Fire, 35 lb, Halon, Fixed (11941) 11-1019	EA	1
48	4210-00-223-9877	Foam, Liquid, Fire Extinguishing (81348) O-F-55	EA	12
49	4240-00-052-3776	Goggles, Plastic, Safety (81348) G-G-531	EA	4
50	2040-00-268-9250	Hook, Boat, 10 feet	EA	2

SECTION III. BASIC ISSUE ITEMS LIST (CONTINUED)

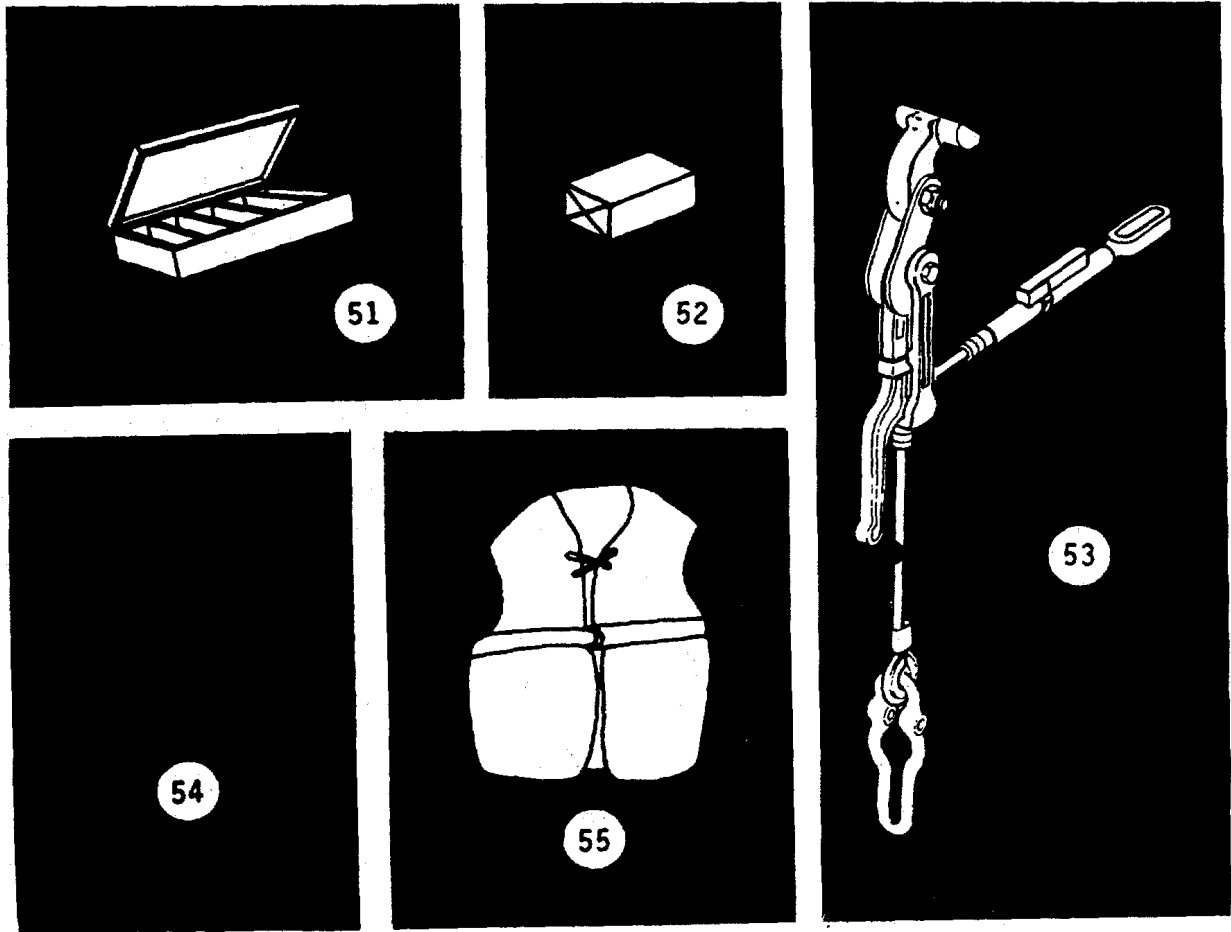

(1) ILLUS NO.	(2) NATIONAL STOCK NUMBER	(3) DESCRIPTION FSCM AND PART NUMBER	(4) USABLE ON CODE U/M	(5) QTY RQR
51	6545-00-922-1200	Kit, First Aid, 12 unit	EA	1
52	6545-00-168-6893	Kit, First Aid, Liferaft	EA	2
53	2020-00-789-1065	Lashing Gear, Vehicle 3500 lb breaking strength (80064) 80513113819	FT	50
54	4940-00-384-0466	Leak Detector, Halide Refrigerant Gas (36346) Prestolite 18 R17	EA	1
55	4220-00-200-0538	Life Preserver, Vest, Adult MIL-L-18045	EA	15

SECTION III. BASIC ISSUE ITEMS LIST (CONTINUED))

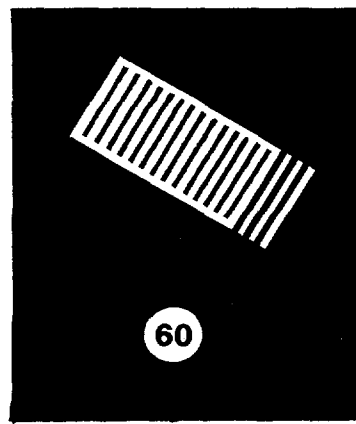
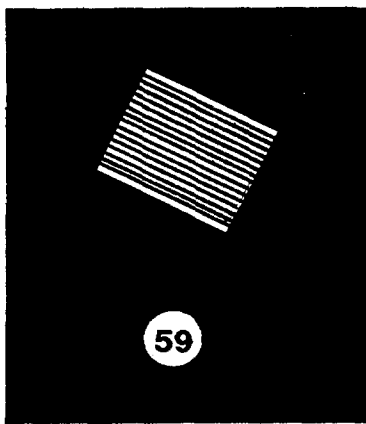
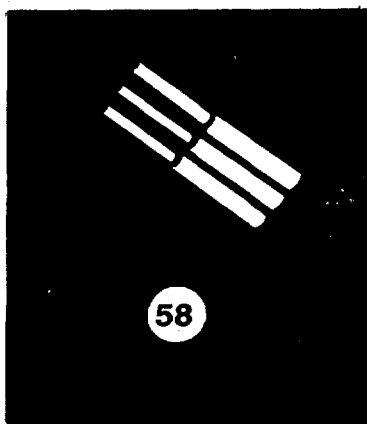
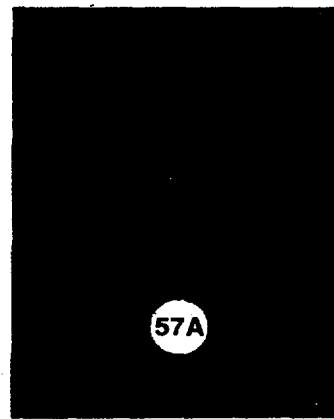
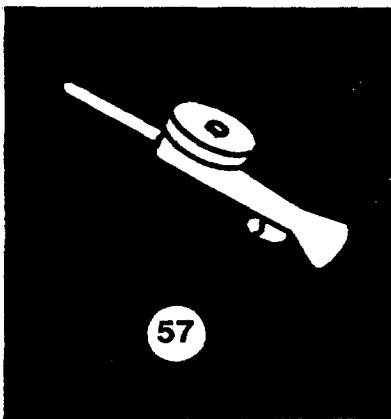
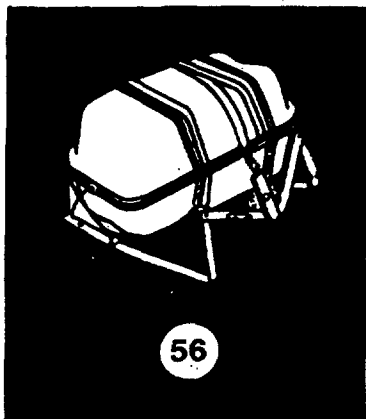

(1) ILLUS NO.	(2) NATIONAL STOCK NUMBER	(3) DESCRIPTION FSCM AND PART NUMBER	(4) USABLE ON CODE U/M	(5) QTY RQR
56		Liferaft, Inflatable, 15 man (98604) MMMK3	EA	2
57	1095-00-270-6019	Line Throwing Device (75324) P/N GR-52-A2	EA	1
57A	1370-01-074-0591	Marker, Location, Marine, MK58, MOD 1 (10001) 3139741	EA	4
58	6850-00-270-9986	Marker, Sea, Fluorescent	EA	4
59	7220-00-634-1601	Mat, Floor, 20 inches x 20 inches (81349) M-19018	EA	2
60	7220-00-292-2096	Mat, Floor, Rubber or Plastic 36 inches x 30 inches x 1/4 inch	EA	4

SECTION III. BASIC ISSUE ITEMS LIST (CONTINUED))

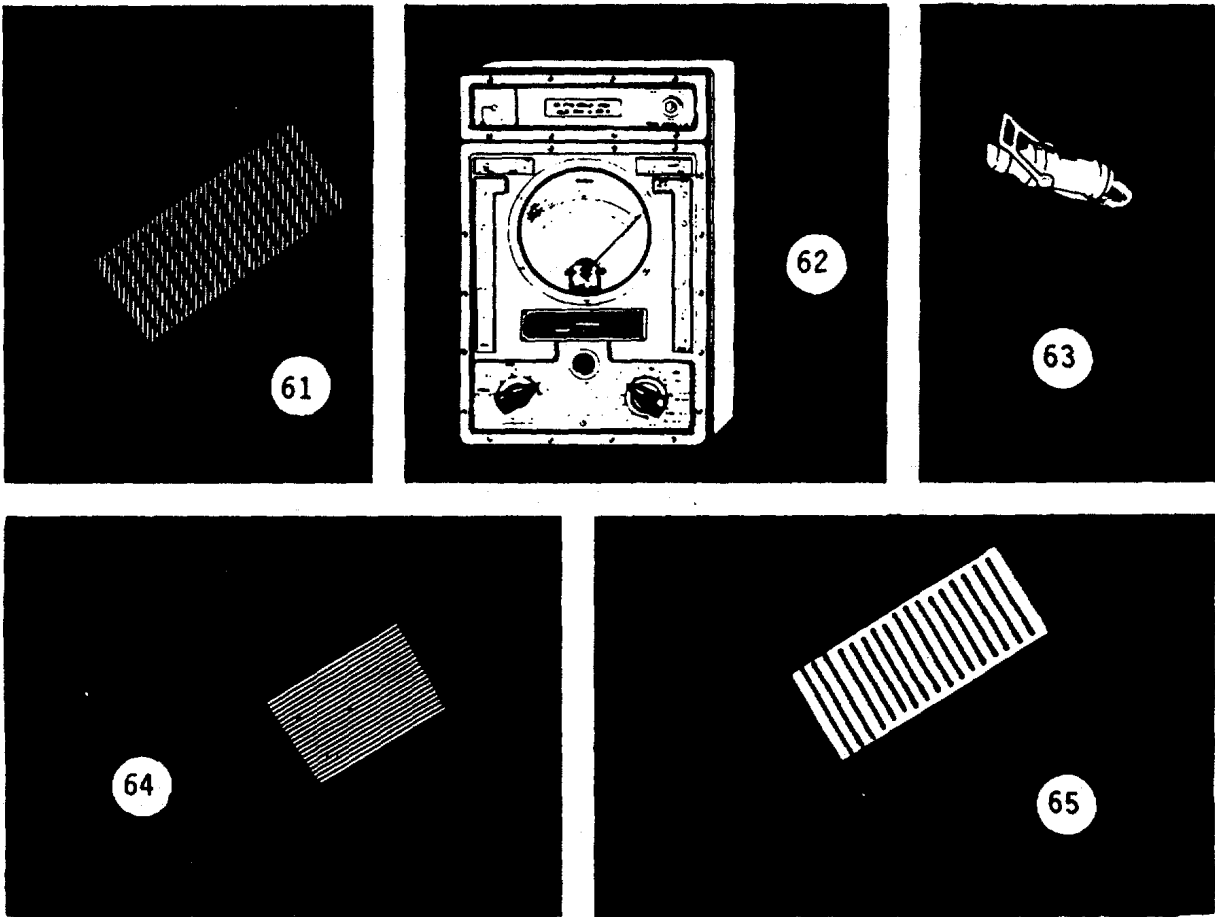

(1) ILLUS NO.	(2) NATIONAL STOCK NUMBER	(3) DESCRIPTION FSCM AND PART NUMBER	USABLE ON CODE	(4) U/M	(5) QTY RQR
61	7220-00-255-0765	Mat, Floor, Safety, Rubber 24 inches x 22 feet x 3/16 inch		EA	1
62	6625-00-553-0142	Multimeter (77221) P/N T-S-352 B/U U/P \$100		EA	1
63	4210-00-225-6225	Nozzle, Fire, Foam, NPU 1 1/2 inches, Type 1 Class C (81349) N-122796		EA	5
64	7220-00-292-2096	Mat, Floor, Black, Rubber or Plastic 36 inches x 30 inches x 1/4 inch (81349) M-910		EA	4
65	7220-00-255-0765	Mat, Floor, Safety, Rubber 24 inches x 22 feet x 3/16 inch		EA	1

SECTION III. BASIC ISSUE ITEMS LIST (CONTINUED)

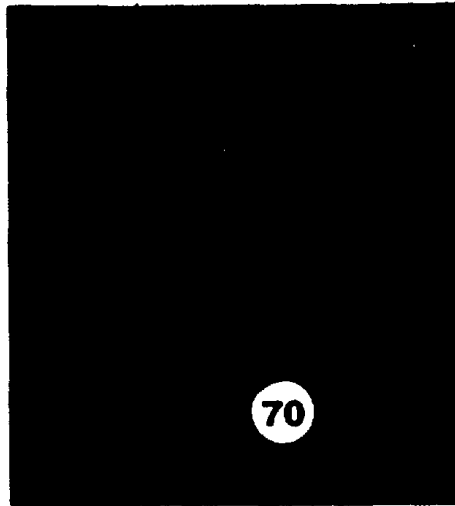
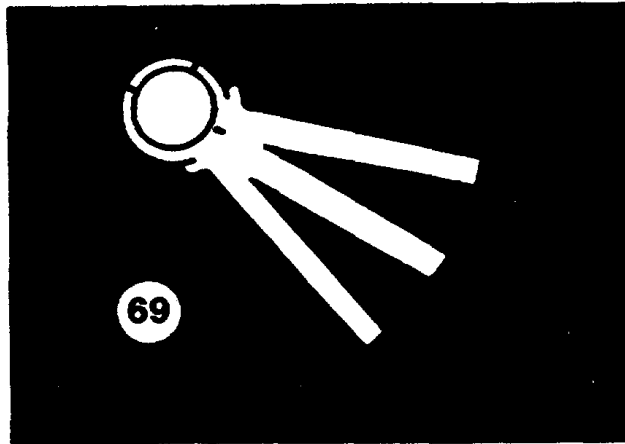

(1) ILLUS NO.	(2) NATIONAL STOCK NUMBER	(3) DESCRIPTION FSCM AND PART NUMBER	(4) USABLE ON CODE U/M	(5) QTY RQR
66	Deleted			
67	Deleted			
68	Deleted			
69	6675-00-191 -1514	Protractor, Plastic, 3 Arm (81 349) P-288, Type II	EA	1
70	4240-00-691 -5617	Protector, Aural (71483) 117	EA	6

SECTION III. BASIC ISSUE ITEMS LIST (CONTINUED)

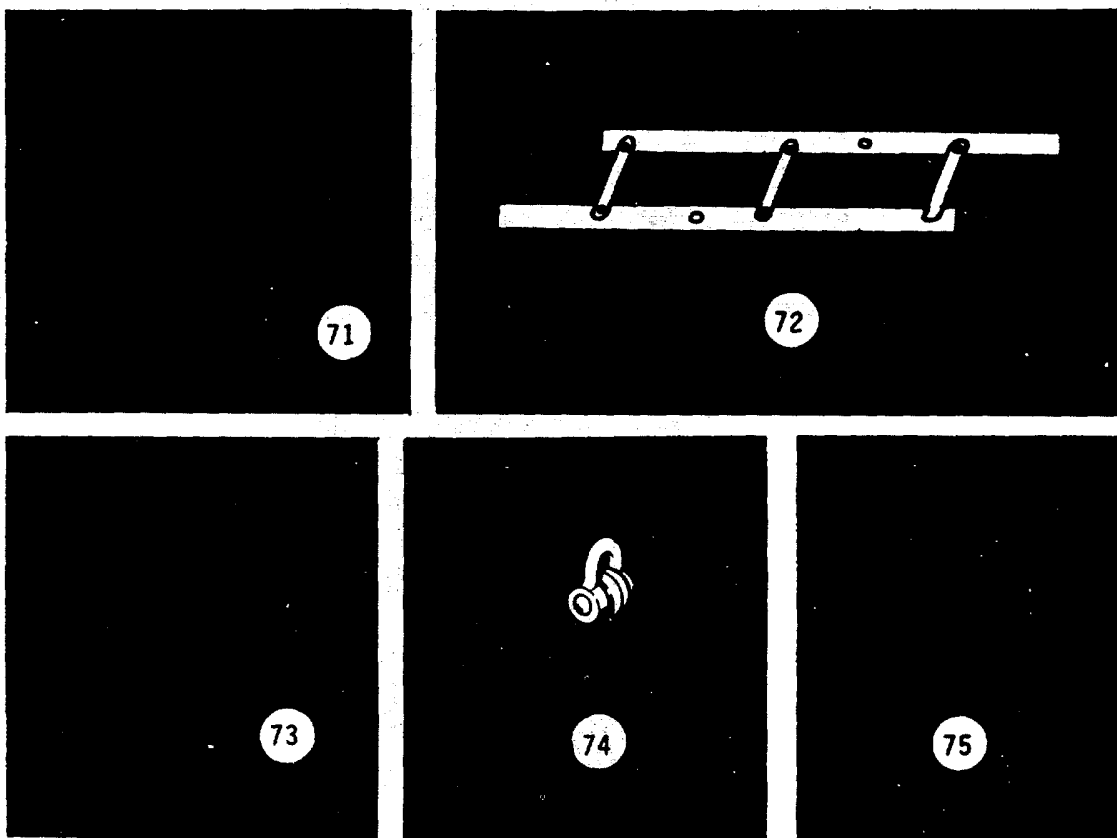

(1) ILLUS NO.	(2) NATIONAL STOCK NUMBER	(3) DESCRIPTION FSCM AND PART NUMBER	(4) USABLE ON CODE U/M	(5) QTY RQR
71	4240-00-368-6149	Respirator, Air Filter (81349) R-3308	EA	4
72	6675-00-191-1509	Ruler, Parallel, 18 inches Navigators (81348) GG-P-kk8	EA	1
73	6605-00-391-1110	Rule, Slide, Nautical	EA	1
74	4030-00-834-1232	Shackle, Anchor, 1 1/2 1/4 between eyes, 130000 lb breaking strength	EA	2
75	4240-00-240-5141	Shield, Face, Industrial Clear	EA	2

SECTION III. BASIC ISSUE ITEMS LIST (CONTINUED).

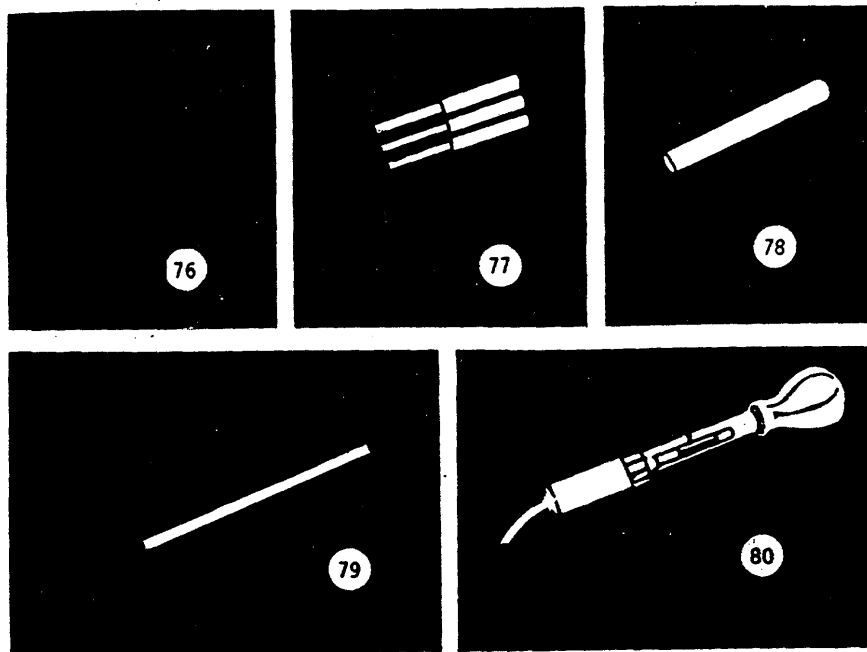

(1) ILLUS NO.	(2) NATIONAL STOCK NUMBER	(3) DESCRIPTION FSCM AND PART NUMBER	USABLE ON CODE	(4) U/M	(5) QTY RQR
76	4240-00-240-5140	Shield, Face, Industrial Amber		EA	2
77	1370-01-030-8330	Signal, Smoke & Illumination, Marine, MK124,MOD O (10001) DL3139734		EA	12
78	1370-00-629-2336	Signal, Illumination, Ground, Red Star, Parachute, M1 26A1 (1 9203) 8797968		EA	4
79	5210-00-526-0752	Tape, Tank Measuring, 50 feet (37163) 14075		EA	1
80	6630-00-171-5126	Tester, Battery, electrolyte Solution (81348) GG-T-258		EA	1

SECTION III. BASIC ISSUE ITEMS LIST (CONTINUED).

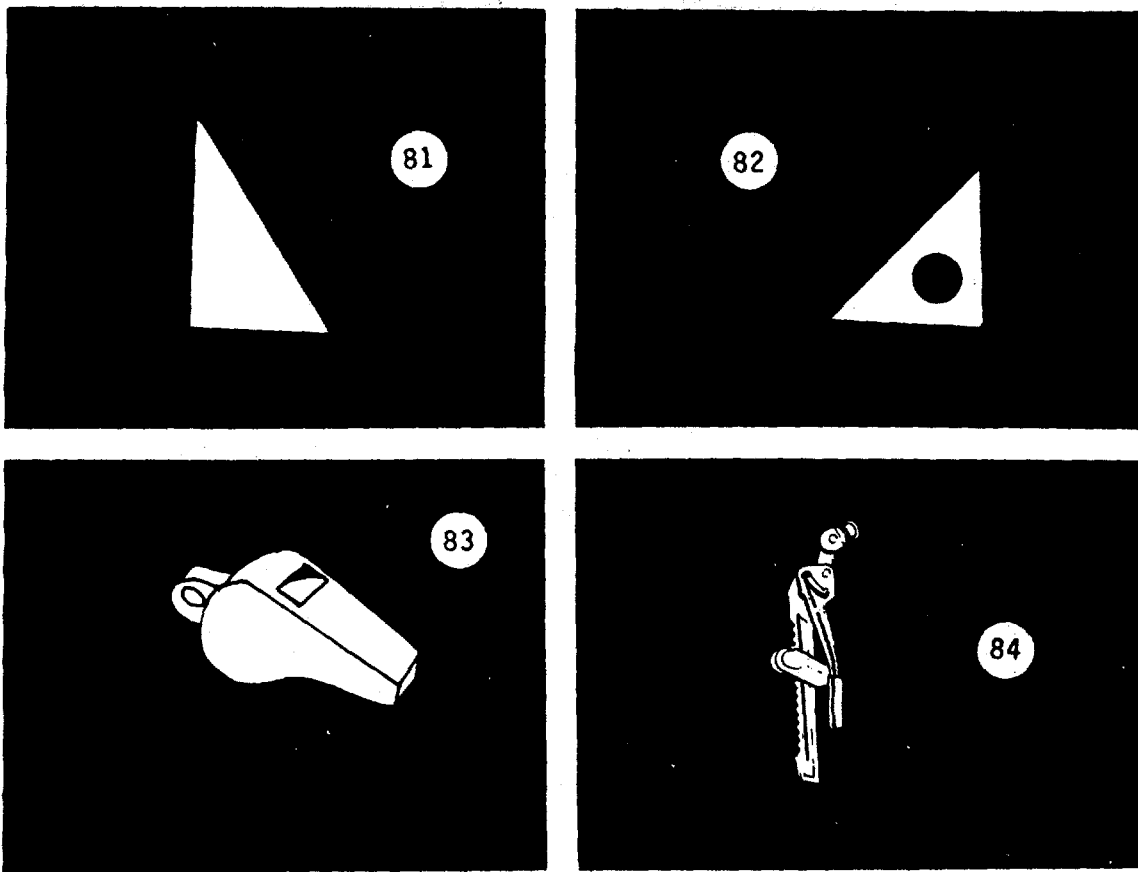

(1) ILLUS NO.	(2) NATIONAL STOCK NUMBER	(3) DESCRIPTION FSCM AND PART NUMBER	(4) USABLE ON CODE U/M	(5) QTY RQR
81	6675-00-190-5867	Triangle, Drafting, Plastic 30 to 60 degree (81348) GG-T-671 Requires Special Handling & storage. Will not be issued as part of Boat Set. Will be requisitioned/furnished by user .	EA	1
82	6675-00-190-5862	Triangle, Drafting, Plastic, 45 degree (81348) GG-T-671	EA	1
83	8465-00-254-8803	Whistle, Ball w/lanyard (81349) W-1053	EA	20
84	2020-00-789-1088	Lashing Gear, Vehicle 9800 lb Breaking Strength (80064) 805-13131520	FT	50

SECTION III. BASIC ISSUE ITEMS LIST (CONTINUED).

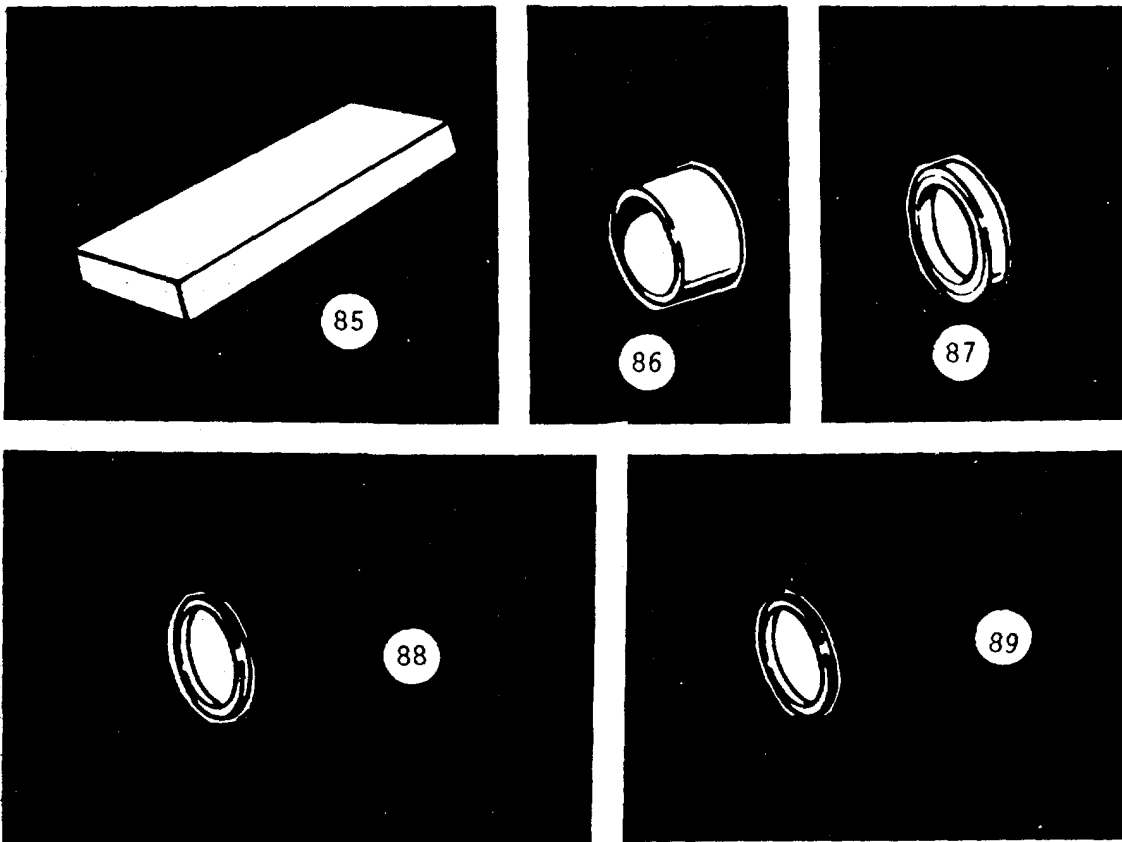

(1) ILLUS NO.	(2) NATIONAL STOCK NUMBER	(3) DESCRIPTION FSCM AND PART NUMBER	(4) USABLE ON CODE U/M	(5) QTY RQR
		The following items are u/o Ship's Service Generator, Engine Detroit Diesel, Allison Division (DDAD) Model 1033-7005-1. Some parts are also u/o: Main Propulsion engines, DDAD Mdl 7122-7000 and Anchor Winch engine DDAD Model 1043-7000.		
85	5330-00-375-2948	Kit, Engine Gasket (72582) 5193113	EA	1
86	5365-00-299-0623	Spacer Crankshaft Seal, Front (72582) 5151475	EA	1
87	5330-00-154-8358	Seal, Crankshaft Front (72582) 5115454	EA	4
88	5330-00-282-5906	Seal, Crankshaft, Rear (72582) 5114335	EA	4
89	5365-00-597-4351	Spacer, Crankshaft Seal Rear (72582) 5192496	EA	1

SECTION III. BASIC ISSUE ITEMS LIST (CONTINUED).

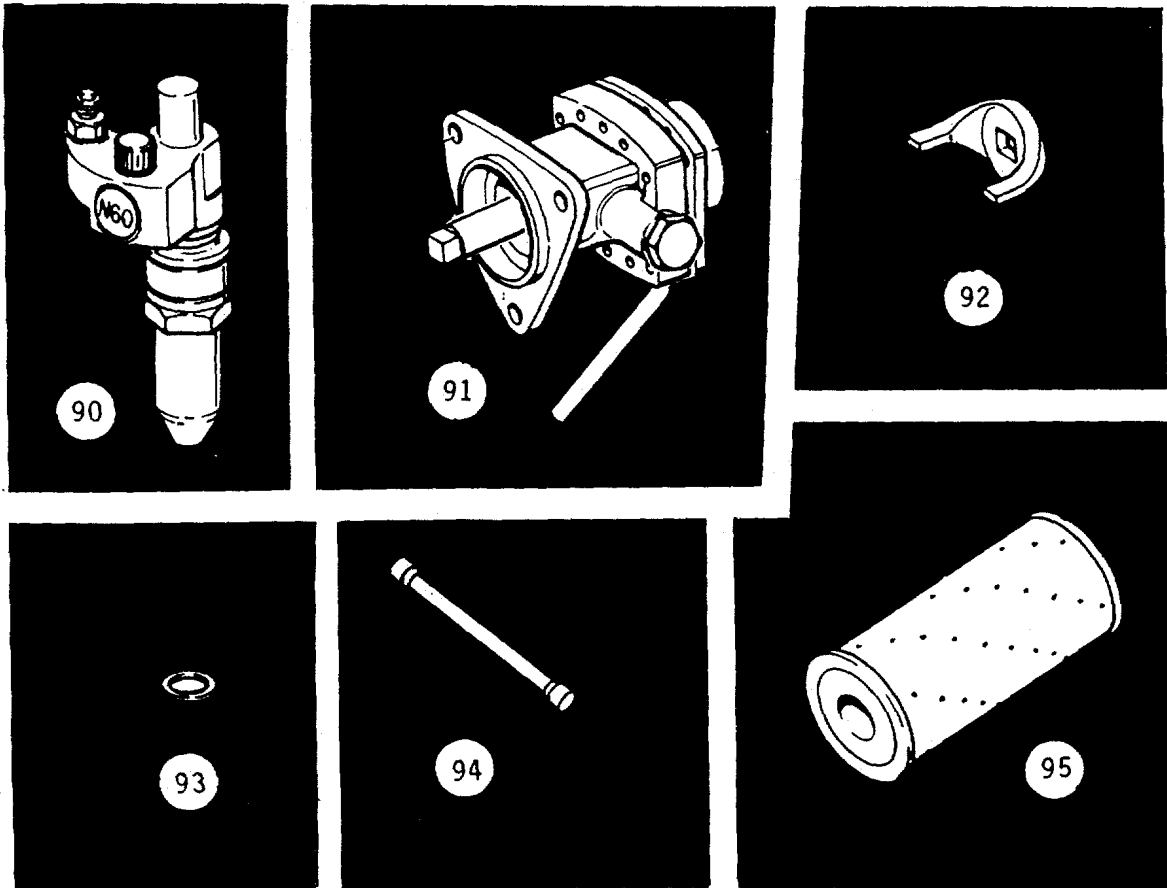

(1) ILLUS NO.	(2) NATIONAL STOCK NUMBER	(3) DESCRIPTION FSCM AND PART NUMBER	(4) USABLE ON CODE U/M	(5) QTY RQR
90	2910-00-075-7474	Injector, Fuel (N60) (72582) 5228760	EA	3
91	2910-00-808-2655	Pump, Fuel (72582) 5199561	EA	2
92	2910-00-524-7862	Fork, Fuel Pump Drive (72582) 5102257	EA	4
93	5310-00-785-3961	Washer, Fuel Connector (72582) 5125108	EA	6
94	2815-00-623-1467	Shaft, Drive, Blower (72582) 5154638	EA	1
95	2940-00-589-6283	Element, Filter, L.O. (72582) 5573014	EA	48

SECTION III. BASIC ISSUE ITEMS LIST (CONTINUED).

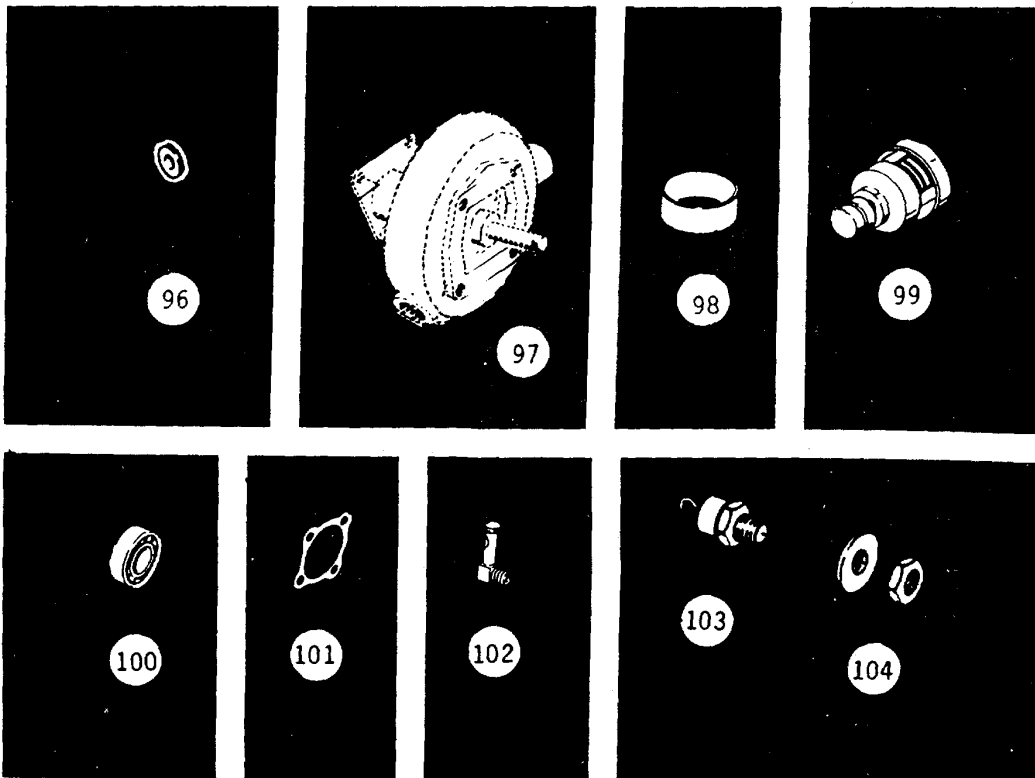

(1) ILLUS NO.	(2) NATIONAL STOCK NUMBER	(3) DESCRIPTION FSCM AND PART NUMBER	(4) USABLE ON CODE U/M	(5) QTY RQR
96	5330-00-604-8094	Seal, Element, L.O. (72582) 5187310	EA	12
97	2930-00-027-2479	Pump, Fresh Water (72582) 5149374	EA	2
98	5330-00-354-1235	Seal, Water	EA	1
99	6620-00-377-3497	Thermostat (72582) 5172141	EA	2
100	3110-00-554-3248	Bearing (72582) 5333914	EA	1
101	5330-00-329-4039	Gasket (72582) 5334586	EA	1
102	6680-00-526-8366	Gauge (72582) 5330431	EA	1
103	5961-00-024-0752	Rectifier (72582) 3179357	EA	6
104	5310-01-040-5346	Nut (72582) 3195233	EA	6

SECTION III. BASIC ISSUE ITEMS LIST (CONTINUED).

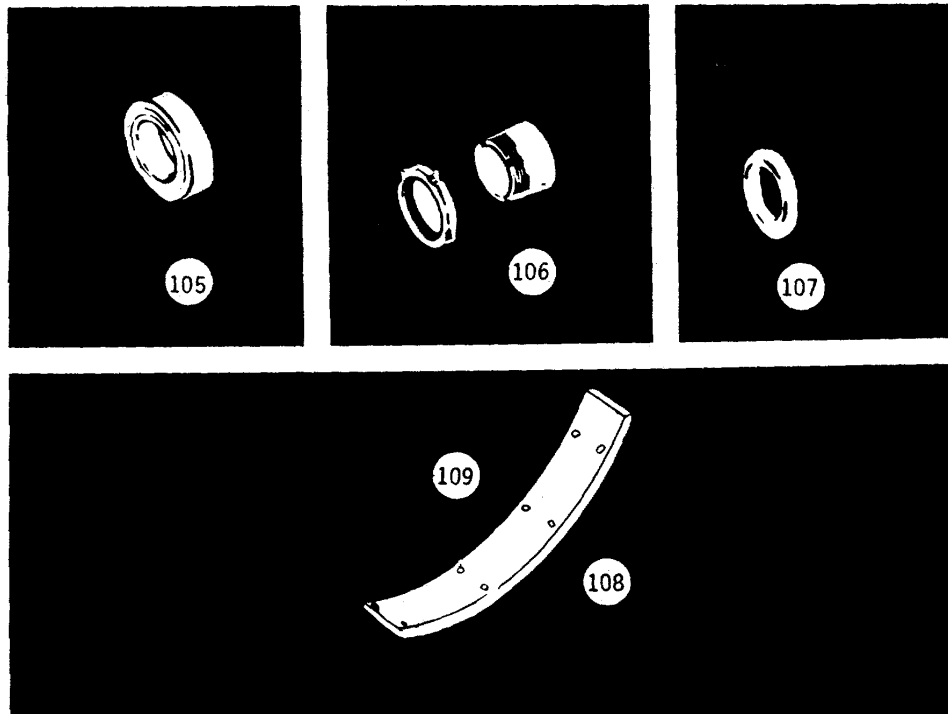

(1) ILLUS NO.	(2) NATIONAL STOCK NUMBER	(3) DESCRIPTION FSCM AND PART NUMBER	USABLE ON CODE	(4) U/M	(5) QTY RQR
		The following 21 items are u/o Bow Ramp Winch (New England Trawler mdl X-1454):			
		WINCH			
105	3110-00-105-2632	Bearing (52676) 22218CK		EA	1
106	3110-00-191-0481	Adapter, Bearing (52676) SNW18		EA	1
107	5330-01-040-3837	Seal, Oil (76727) R-11290-15		EA	1
108	2030-01-068-5324	Lining, Brake (76727) B-11292-1		EA	1
109	5320-01-069-2663	Rivets, Brake Band (76727) B11292-4		EA	22

SECTION III. BASIC ISSUE ITEMS LIST (CONTINUED).

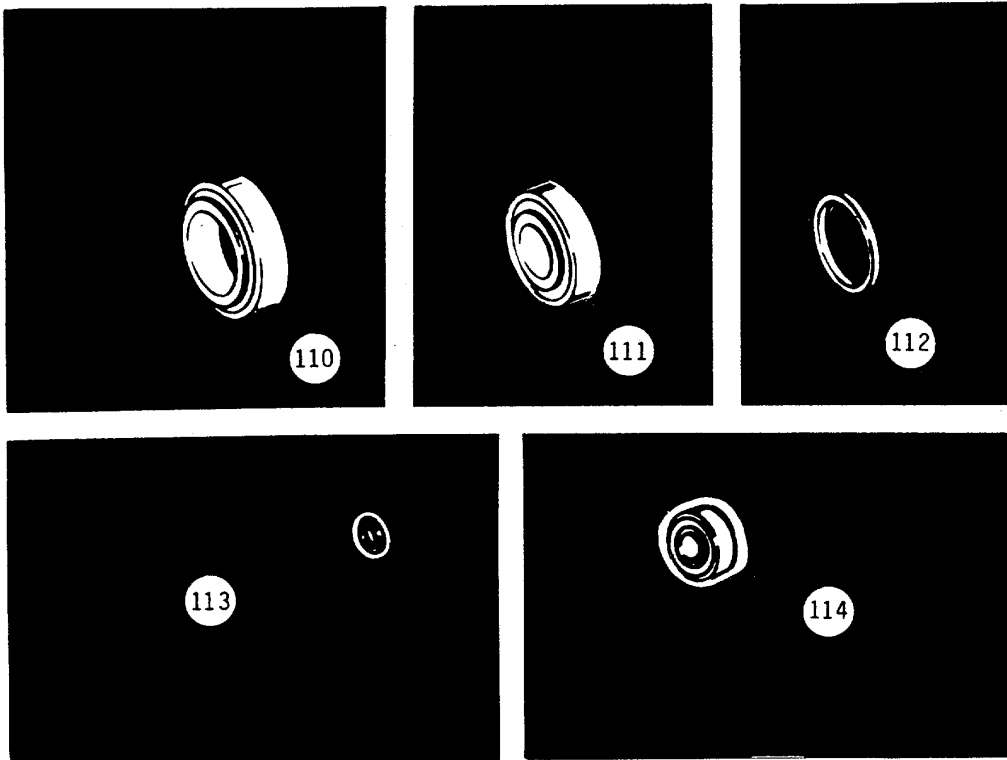

(1) ILLUS NO.	(2) NATIONAL STOCK NUMBER	(3) DESCRIPTION FSCM AND PART NUMBER	USABLE ON CODE	(4) U/M	(5) QTY RQR
		HORSBURG - SCOTT 90T SPEED REDUCER			
110	3110-00-001-4769	Bearing, Slow Speed (60038) JM718149/JM718110		EA	2
111	3110-00-115-6105	Bearing, Slow Speed (60038) H414249/H414210		EA	2
112	5330-00-477-0225	Seal, Slow Speed (29386) 34861		EA	1
113	5330-00-888-6345	Seal, High Speed (29386) CR11124 STERLING POWER 15 HP MOTOR		EA	1
114	3110-00-114-6000	Bearing (38443) 308SZZ		EA	2

SECTION III. BASIC ISSUE ITEMS LIST (CONTINUED).

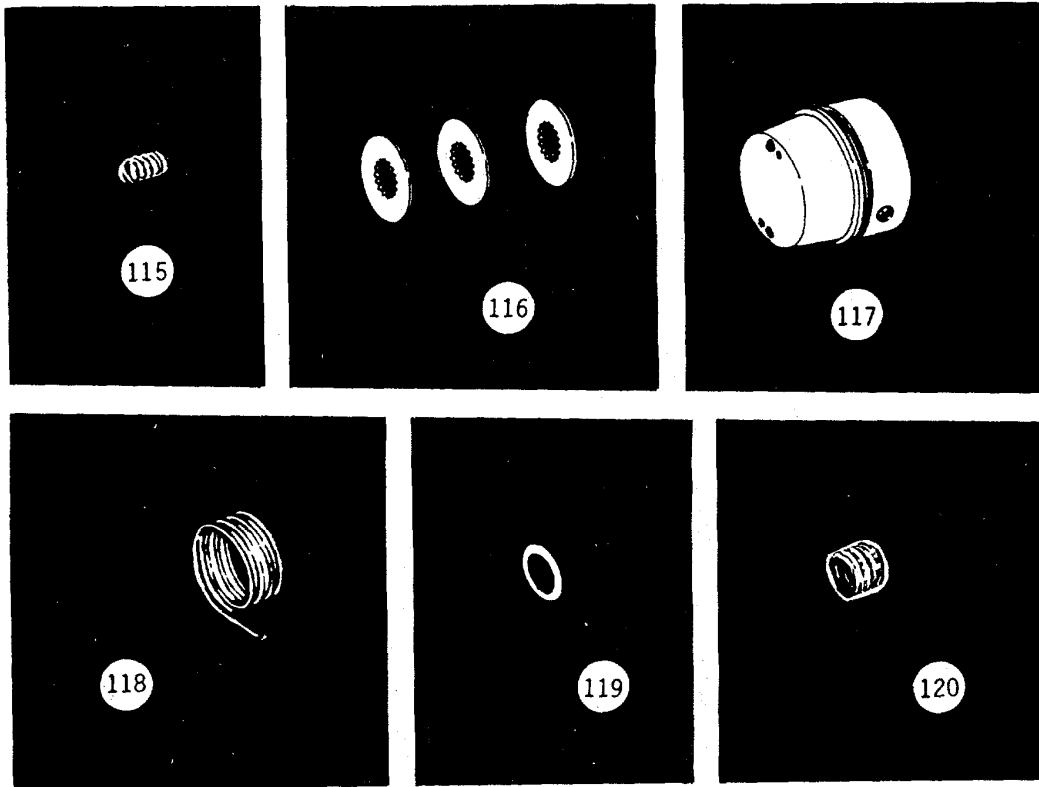

(1) ILLUS NO.	(2) NATIONAL STOCK NUMBER	(3) DESCRIPTION FSCM AND PART NUMBER	USABLE ON CODE	(4) U/M	(5) QTY RQR
		DINGS MDL 5-73050-4 50 LB BRAKE			
115	5360-00-021-1547	Spring, Pressure (17904) G700-12		EA	1
116	3010-00-718-4525	Disc, Friction (17904) H70103		EA	2
117	5950-01-039-7161	Magnet, Brake (17904) R73050-4 NAMCO SNAP-LOCK LIMIT SWITCH & MARINE SWITCH		EA	1
118	5360-01-017-2522	Spring, Torsion (42337) EH160-03892		EA	2
119	5330-01-042-2328	"O" Ring (51238) EH080-00063		EA	2
120	5360-01-017-2493	Spring, Cam (51238) EH160-03898		EA	2

SECTION III. COMPONENTS OF END ITEMS LIST

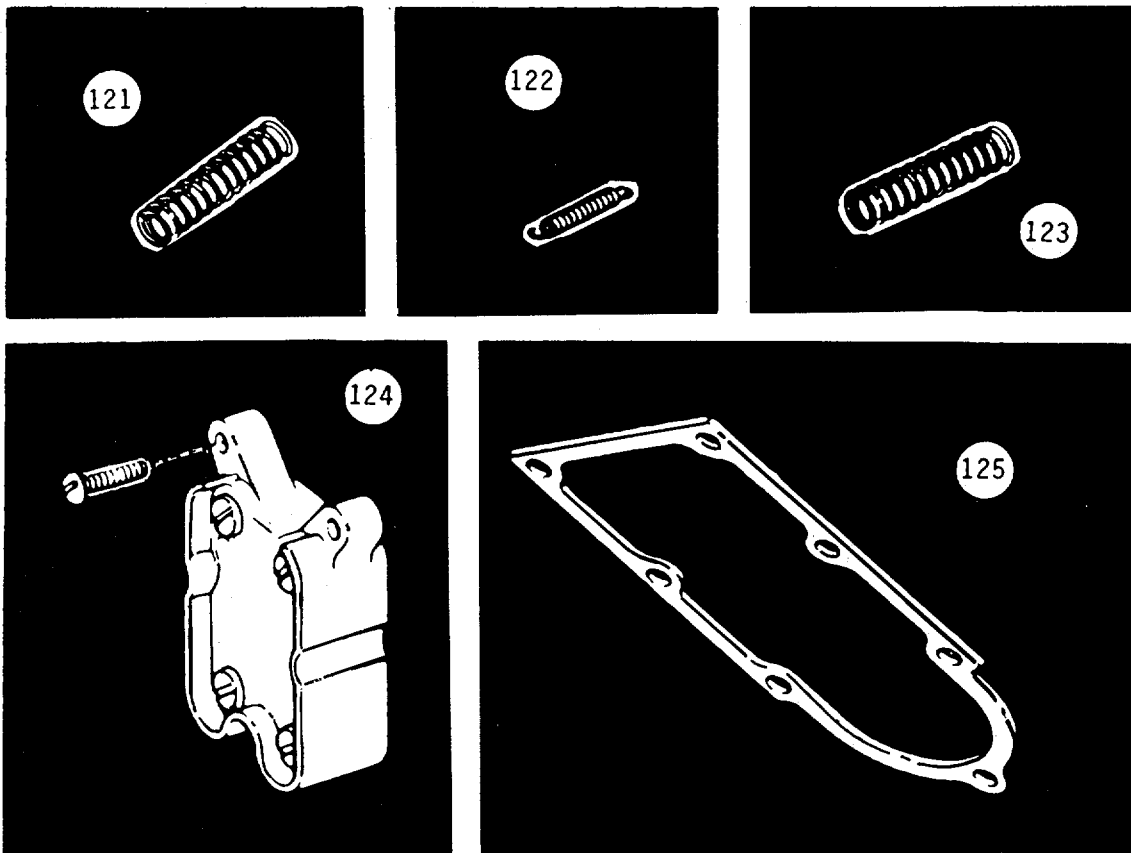

(1) ILLUS NO.	(2) NATIONAL STOCK NUMBER	(3) DESCRIPTION FSCM AND PART NUMBER USABLE ON CODE	(4) U/M	(5) QTY RQR
121	5360-01-017-2523	Spring, Slide (51238) EH160-03899	EA	1
122	5360-01-017-2494	Spring, Latch (51238) EH160-03897	EA	1
123	5360-01-017-2524	Spring, Slide Return (51238) EH160-03704	EA	1
124	5930-01-024-0877	Block, Assy, Contact (51238) EA711-11601	EA	1
125	5330-01-041-0699	Gasket, Bottom Cover EA780-10100-91	EA	1

SECTION III. BASIC ISSUE ITEMS LIST (CONTINUED).

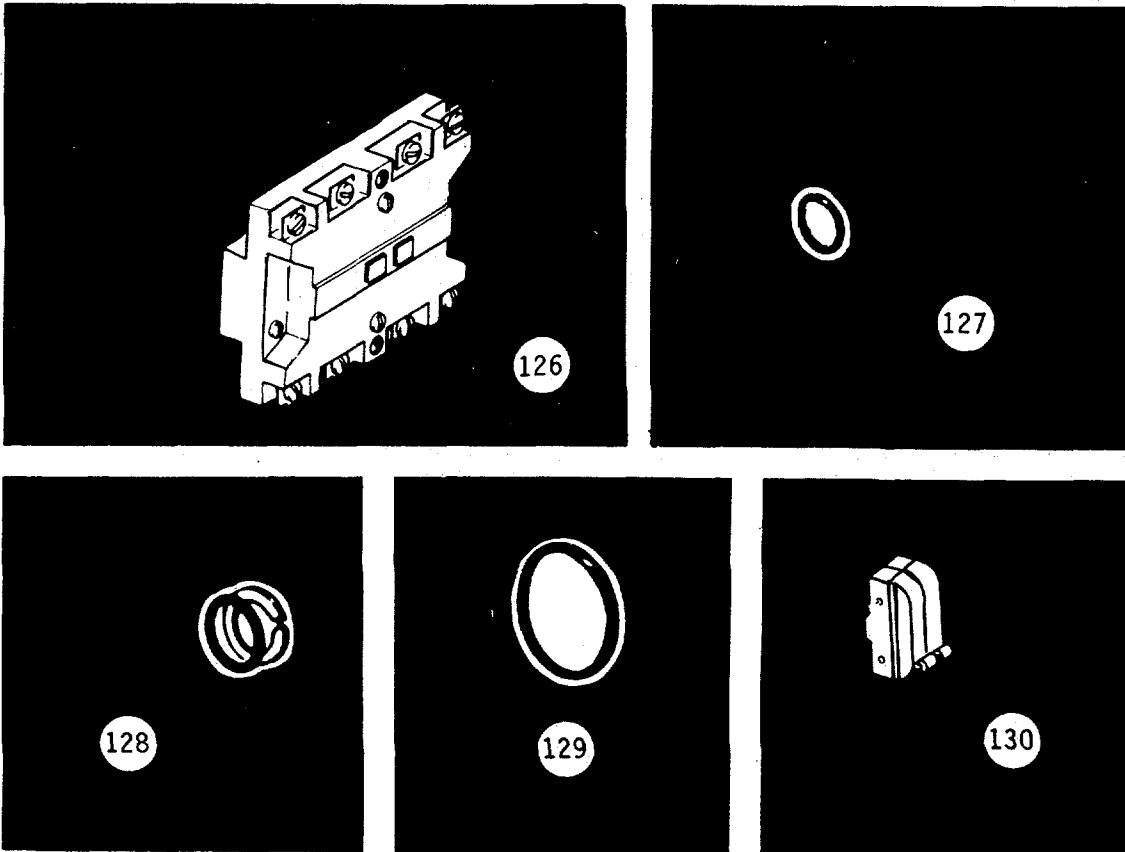

(1) ILLUS NO.	(2) NATIONAL STOCK NUMBER	(3) DESCRIPTION FSCM AND PART NUMBER	(4) USABLE ON CODE U/M	(5) QTY RQR
		The following 21 items are u/o Sperry Steering System:		
126	5950-00-018-9265	Coil, Starter (01411) 505C806G1	EA	1
127	5330-00-434-1487	"O" Ring, 3/4 x 1 (30780) ARP568-210	EA	2
128	5330-00-835-3007	"O" Ring & Backup, 1 1/4 x 1 1/2 (30780) ARP568-218	EA	2
129	5330-00-984-3762	"O" Ring, 2 1/4 x 2 1/2 (30780) ARP568-228	EA	2
130	5930-01-063-2958	Switch, Micro (56232) 771614	EA	2

SECTION III. BASIC ISSUE ITEMS LIST (CONTINUED).

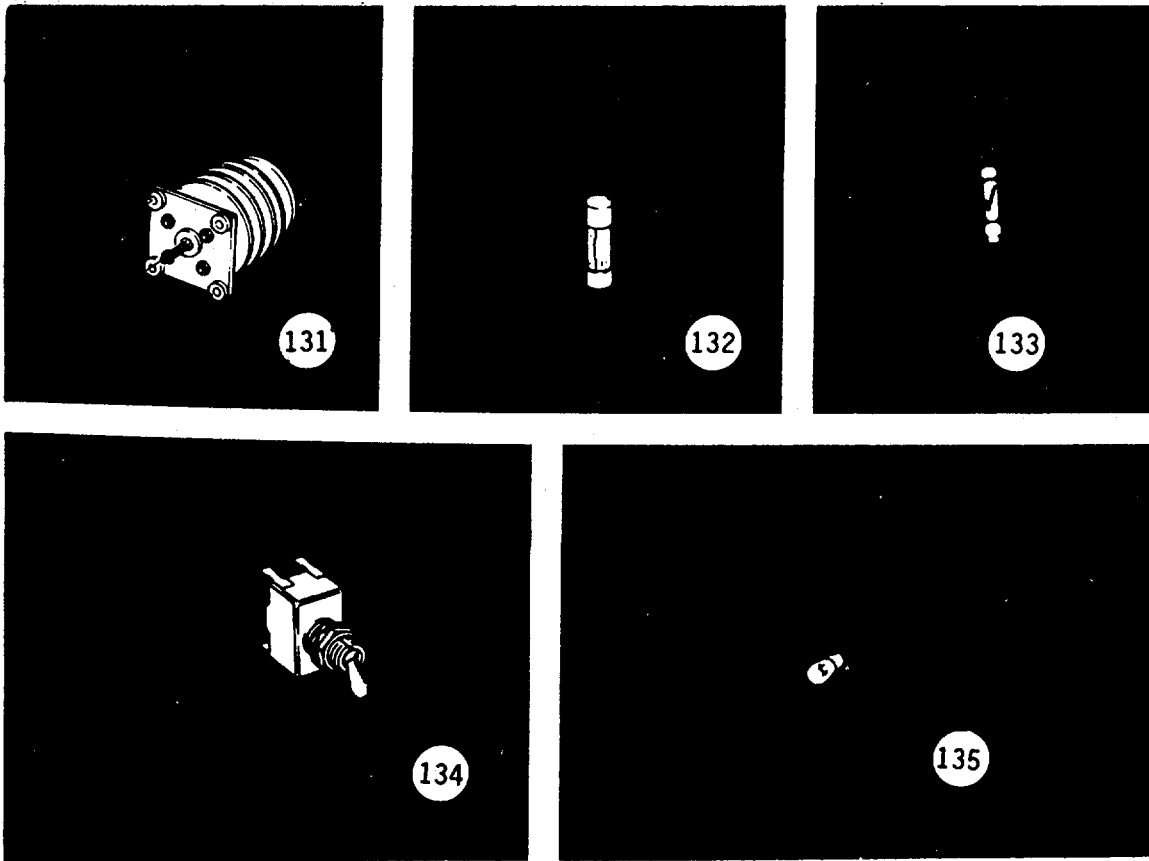

(1) ILLUS NO.	(2) NATIONAL STOCK NUMBER	(3) DESCRIPTION FSCM AND PART NUMBER	(4) USABLE ON CODE U/M	(5) QTY RQR
131	5930-01-017-0342	Switch, Operator (27191) E30AD	EA	1
132	5920-00-280-4960	Fuse (81349) F02A250V 2A	EA	5
133	5920-00-284-6787	Fuse (81349) R02A250V 5A	EA	10
134	5930-00-683-1628	Switch, Toggle (96906) MS24523-22	EA	1
135	6240-00-939-7859	Lamp (71744) 120MB	EA	10

SECTION III. BASIC ISSUE ITEMS LIST (CONTINUED).

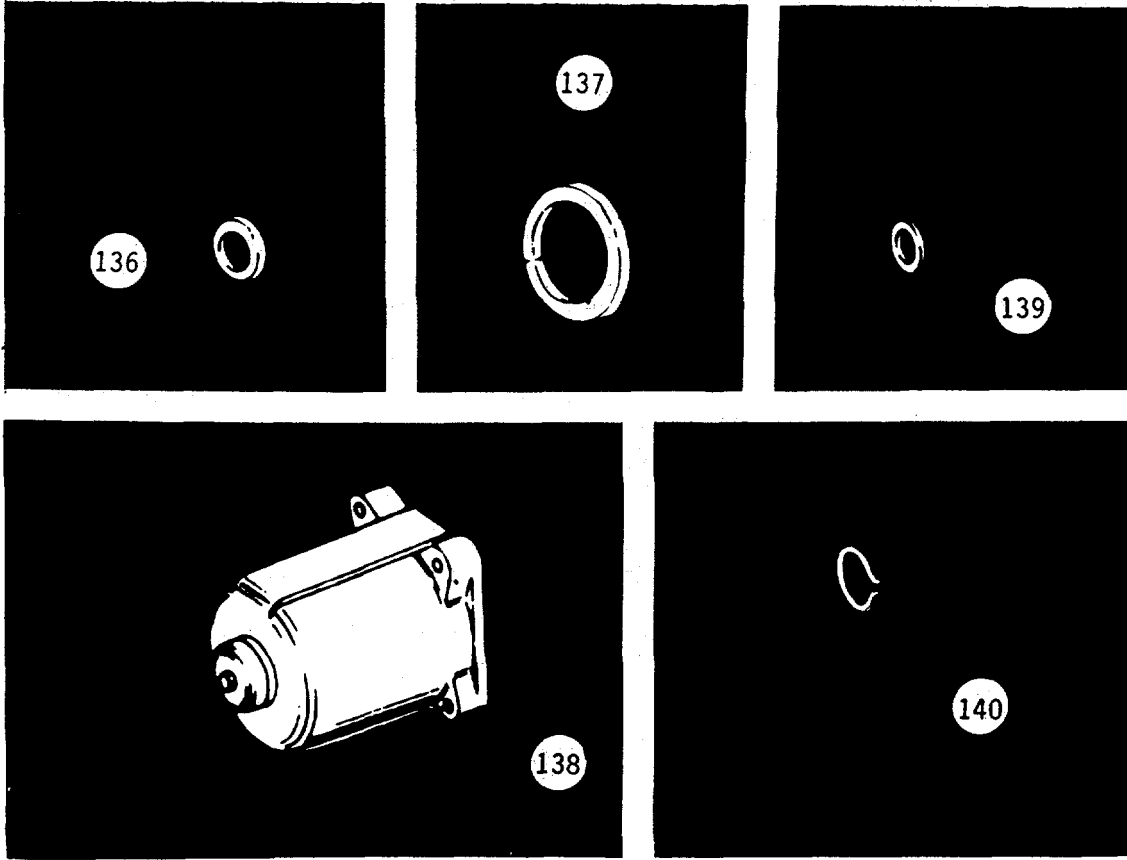

(1) ILLUS NO.	(2) NATIONAL STOCK NUMBER	(3) DESCRIPTION FSCM AND PART NUMBER	(4) USABLE ON CODE U/M	(5) QTY RQR
136	5330-01-021-3786	Cup, Seal, Rod, 1 x 1 3/8 (02697) 18701000	EA	2
137	5330-01-021-3787	Cup, Seal, 2 1/8 x 2 1/2 (83259) 18702125	EA	4
138	5945-00-967-4798	Solenoid (62983) 195053	EA	1
139	5310-01-040-5372	Washer (62983) 211846	EA	2
140	5845-00-999-2985	Ring, Retaining (62983) 236797	EA	1

SECTION III. BASIC ISSUE ITEMS (CONTINUED).

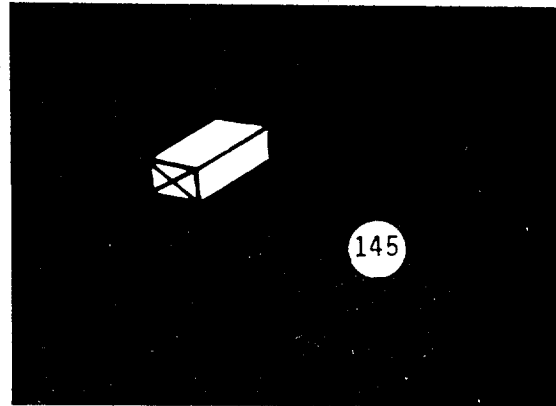
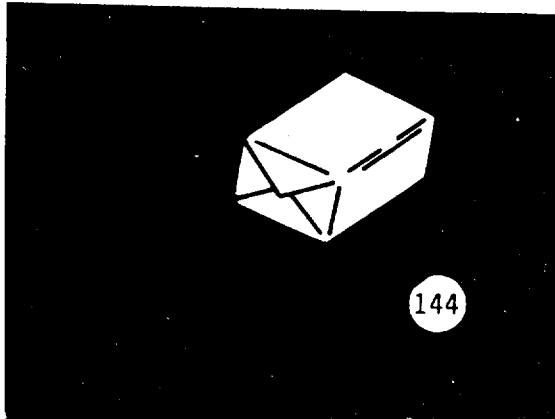
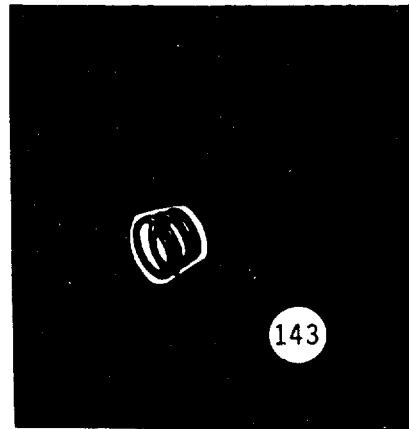
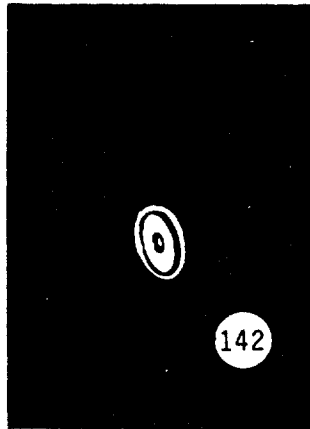
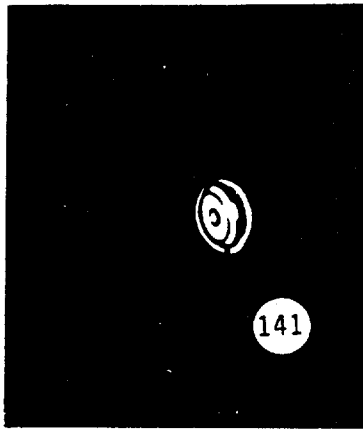

(1) ILLUS NO.	(2) NATIONAL STOCK NUMBER	(3) DESCRIPTION FSCM AND PART NUMBER	(4) USABLE ON CODE U/M	(5) QTY RQR
141	5315-00-159-2781	Guide, Spring (62983) 281422	EA	3
142	4810-00-059-6729	Washer (62983) 281423	EA	2
143	5360-00-059-6725	Spring (62983) 290072	EA	1
144	5330-01-073-0865	Gasket Kit (62983) 919190	EA	1
145	5330-01-040-7788	Gasket Kit (62983) 919428	EA	1

SECTION III. BASIC ISSUE ITEMS LIST (CONTINUED).

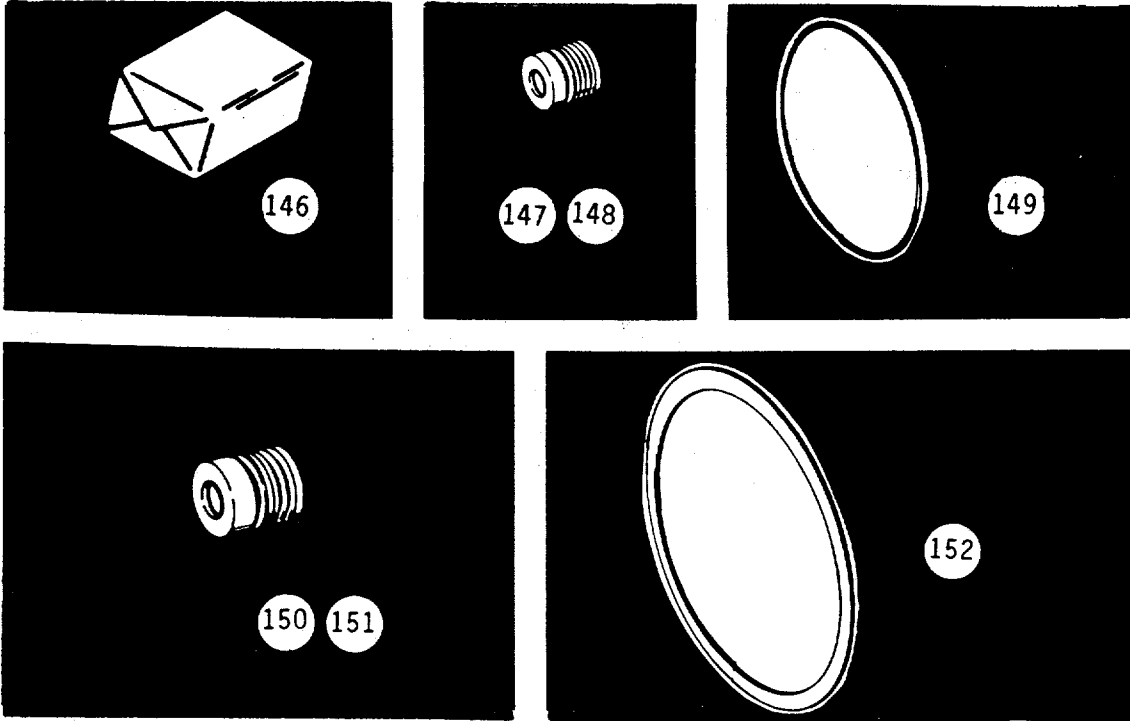

(1) ILLUS NO.	(2) NATIONAL STOCK NUMBER	(3) DESCRIPTION FSCM AND PART NUMBER	USABLE ON CODE	(4) U/M	(5) QTY RQR
146	3930-00-587-7019	Pump Seal Kit (62983) 922733 The following 3 items are u/o Pacific Pumping Co: Fresh Water Pump		EA	1
147	5330-01-011-1441	Seat, Seal (45396) 14008631		EA	1
148	5330-01-040-7772	Seal, Head (45396) 14010237		EA	1
149	5330-01-040-6648	"O" Ring (45396) 17029928G The following 3 items are u/o Pacific Pumping Co. Salt Water Cooling Pump:		EA	1
150	5330-01-040-3920	Gasket Case (45396) 11005688X006		EA	1
151	5330-01-011-1441	Seal, Seat (45396) 14008631		EA	1
152	5330-01-040-7772	Seal, Head (45396) 4010237		EA	1

SECTION III. BASIC ISSUE ITEMS LIST (CONTINUED).

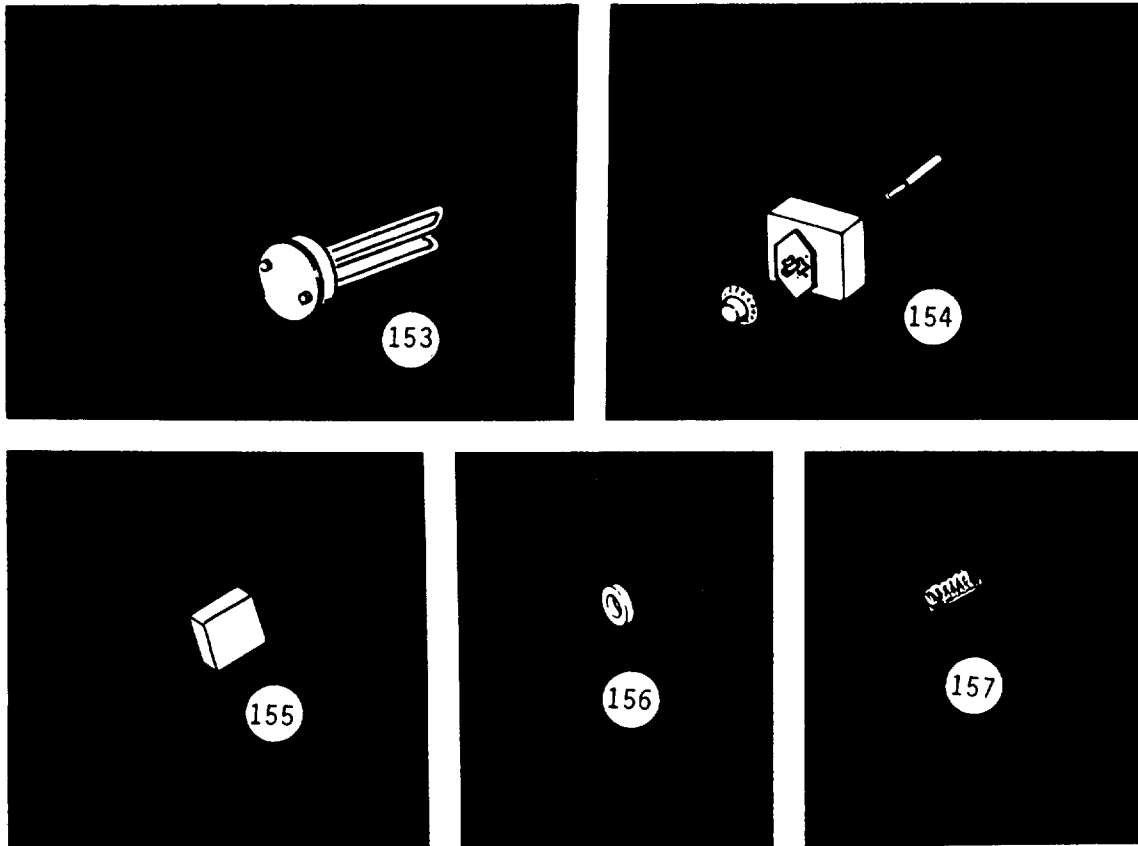

(1) ILLUS NO.	(2) NATIONAL STOCK NUMBER	(3) DESCRIPTION FSCM AND PART NUMBER	(4) U/M	(5) QTY RQR
		The following 2 items are u/o Electric Heater Co. Hot Water Heater		
153	4540-00-938-2907	Element, Heater (19857) 3-38682	EA	1
154		Switch, Thermostatic (19857) DIA-Z-52162-006	EA	1
		The following 3 items are u/o Blackmer Pump Co. Lube Oil Transfer Pump:		
155	4320-00-712-1452	Vane (07524) 090405	EA	3
156	5330-00-054-4946	Packing (07524) 300105	EA	1
-157	5360-00-776-7201	Spring (07524) 110401	EA	3

SECTION III. BASIC ISSUE ITEMS LIST (CONTINUED).

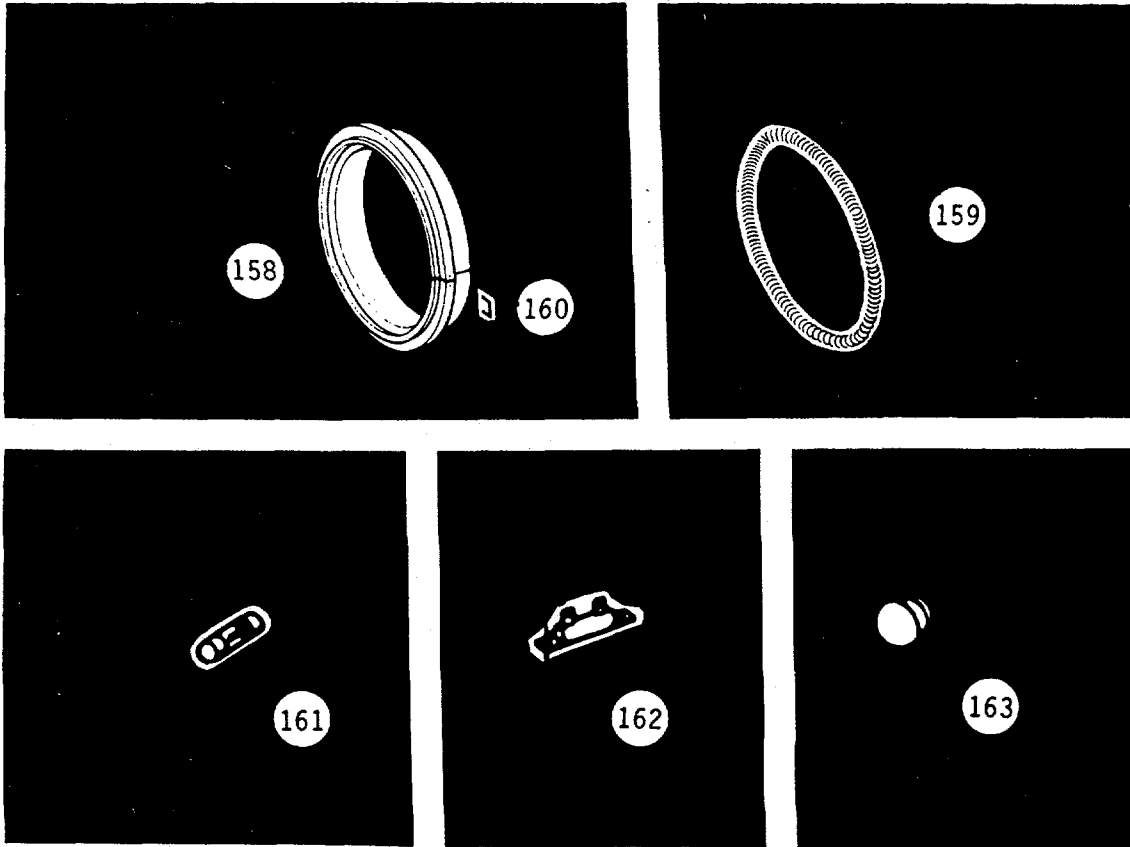

(1) ILLUS NO.	(2) NATIONAL STOCK NUMBER	(3) DESCRIPTION FSCM AND PART NUMBER	(4) USABLE ON CODE U/M	(5) QTY RQR
		The following 3 items are u/o The Propeller Shaft Syntron Seal by RMC Corp.		
158	5330-00-650-2587	Element, Sealing (58849) 52384	EA	4
159	5360-00-619-0773	Spring, Garter (58849) 52385	EA	4
160	5315-00-664-0696	Staple, Barbed (58849) 44244		
		The following 3 items are u/o Electrol Specialties Ship's Service Switchboard.		
161	5920-00-539-6920	Fuse (71400) ABC-30	EA	5
162	5905-00-892-0337	Resistor (71400) 0214	EA	1
163	6240-00-143-7432	Lamp, Indicator (96906) MS15579-6	EA	5

SECTION III. BASIC ISSUE ITEMS LIST (CONTINUED).

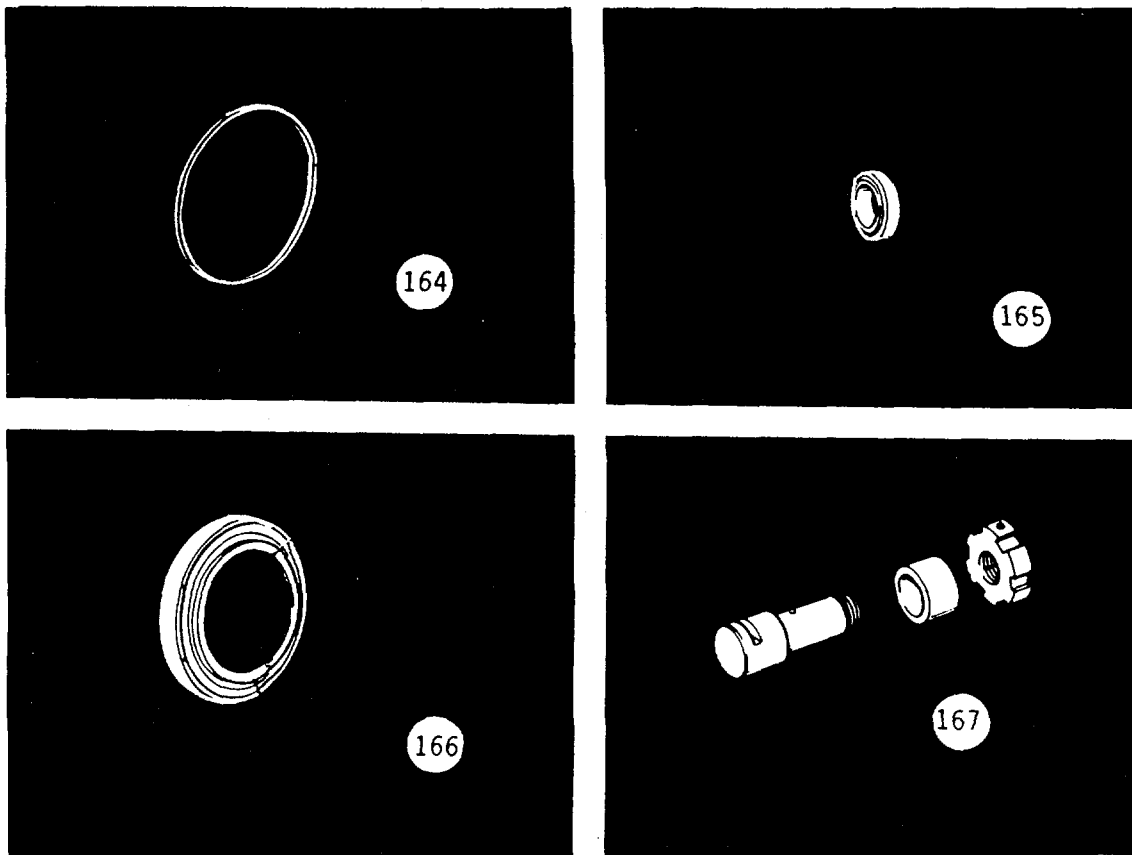

(1) ILLUS NO.	(2) NATIONAL STOCK NUMBER	(3) DESCRIPTION FSCM AND PART NUMBER	(4) USABLE ON CODE U/M	(5) QTY RQR
		The following 4 items are u/o Anchor Cable Swivel Fairleader by Smith-Berger Corp.		
164	5330-01-073-0905	Seal, Shank (Felt) (15950) MK-2	EA	1
165	3110-00-100-0317	Bearing, Sheave (15950) (60038) 472	EA	2
166	3110-01-101-0797	Bearing, Sheave (15950) M241543-M241510	EA	2
167	5315-01-040-6554	Pin, Sheave w/nut (15950) 31838	EA	2

SECTION III. BASIC ISSUE ITEMS LIST (CONTINUED).

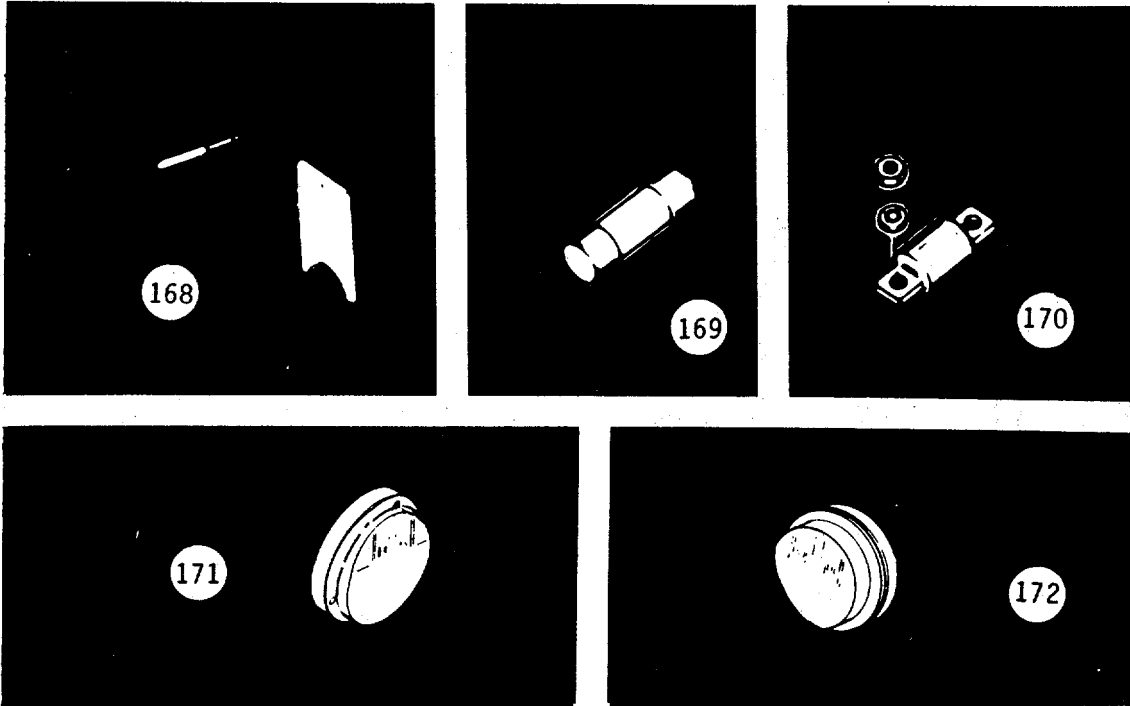

(1) ILLUS NO.	(2) NATIONAL STOCK NUMBER	(3) DESCRIPTION FSCM AND PART NUMBER	(4) USABLE ON CODE U/M	(5) QTY RQR
168	5110-01-038-5815	The following item is u/o Northern Hardware - Wire Rope Cutter. Blade (85767) 135	EA	3
169	5920-00-829-3806	The following 2 items are u/o Lamarche Mfg. Co. - Rectifier. Fuse, Input (45A250V) AC (92731) P-8-45	EA	2
170	5920-00-828-0148	Fuse, Output (80A130V) AC (83698) A13X-80	EA	2
171	5865-01-039-9061	The following 2 items are u/o Hose-McCann Sound Powered Telephone Headset. Unit, Earphone (14100) 702003-277	EA	2
172	5965-01-040-4304	Unit, Transmitter (14100) 702003-278	EA	1

SECTION 111. BASIC ISSUE ITEMS LIST (CONTINUED).

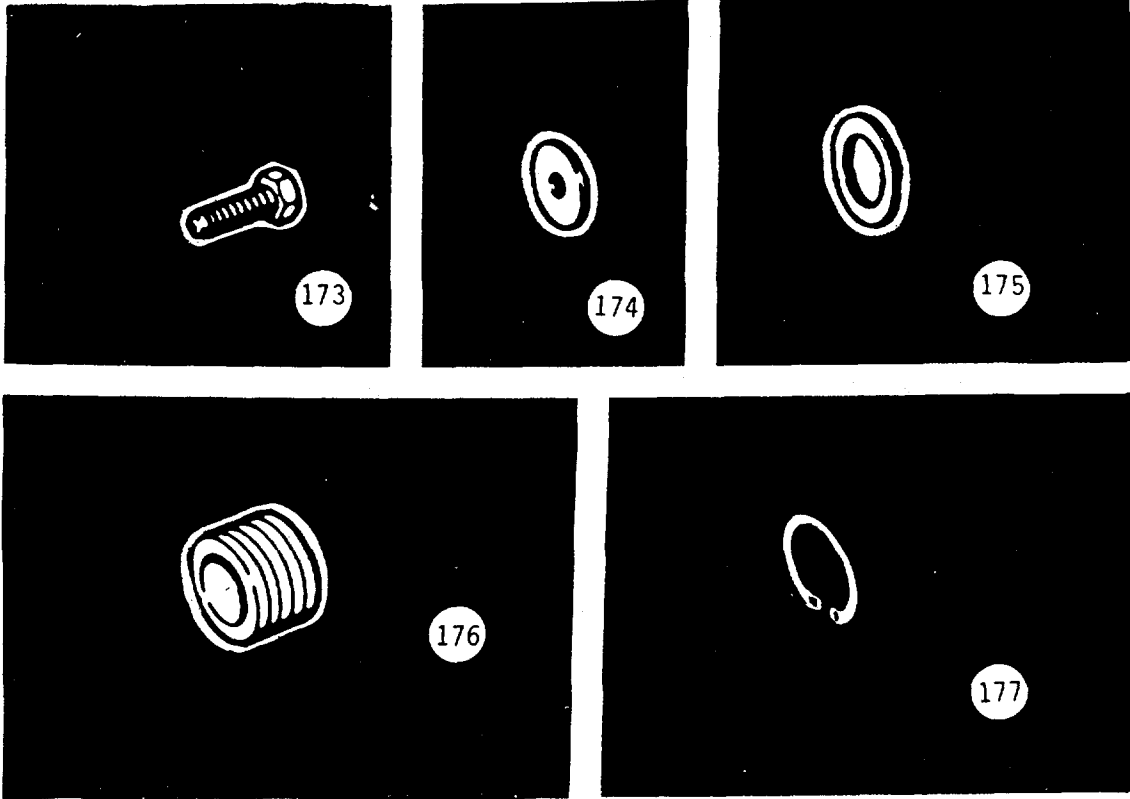

(1) (2) ILLUS NO.	(3) NATIONAL STOCK NUMBER	(4) DESCRIPTION FSCM AND PART NUMBER	USABLE ON CODE	(5) U/M	QTY RQR
		The following 5 items are u/o Air Conditioning with Circulating Pump.			
173	5305-00-057-3969	Capscrew, Impeller (45396) 08023447H303		EA	1
174	5310-00-397-5332	Washer, Impeller (45396) 10001769H303		EA	1
175	5310-00-397-5320	Washer, Packing (45396) 10006510B		EA	1
176	5330-01-040-7773	Packing (45396) 13021775		EA	1
177	5330-01-069-9250	Ring, Packing Retaining (45396) 61025033L		EA	1

SECTION III. BASIC ISSUE ITEMS LIST (CONTINUED).

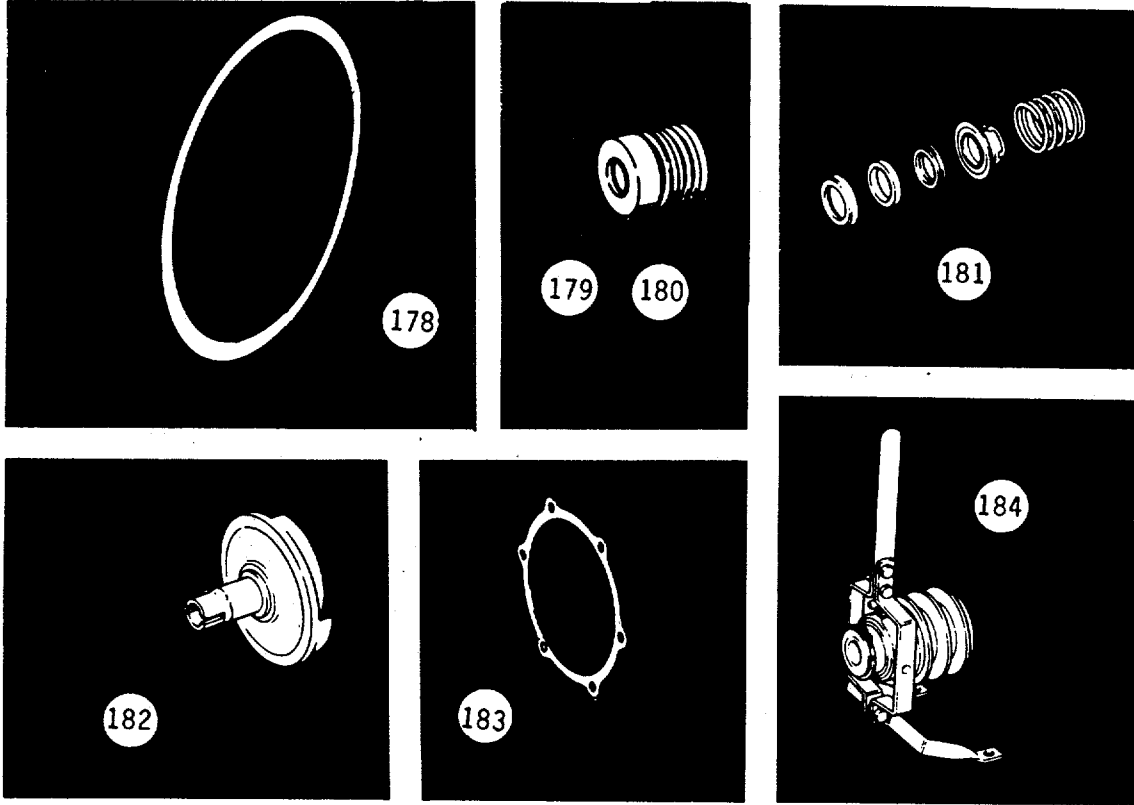

(1) ILLUS NO.	(2) NATIONAL STOCK NUMBER	(3) DESCRIPTION FSCM AND PART NUMBER	(4) USABLE ON CODE U/M	(5) QTY RQR
		The following 3 items are u/o Pacific Pump Co. Flush Water Pump.		
178	5330-01-040-3920	Gasket, Case (45396) 11005688X006	EA	1
179	5330-01-011-1441	Seat, Seal (45396) 14008631	EA	1
180	5330-01-040-7772	Seal, Head (45396) 14010237	EA	1
		The following 4 items are u/o M. P. Pumps Inc. Bilge Pump with Clutch Pack.		
181	4320-00-104-4355	Seal (76122) 22361	EA	1
182	4320-01-040-8838	Impeller (76122) 23037	EA	1
183	5330-01-040-5360	Gasket (76122) 22240	EA	1
184	3010-01-040-4290	Clutch Pak (76122) 24463	EA	1

SECTION III. BASIC ISSUE ITEMS LIST (CONTINUED).

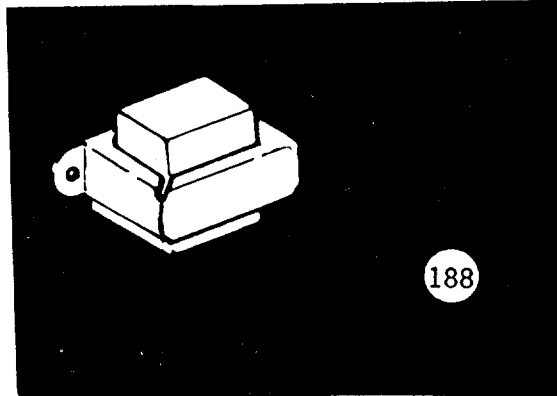
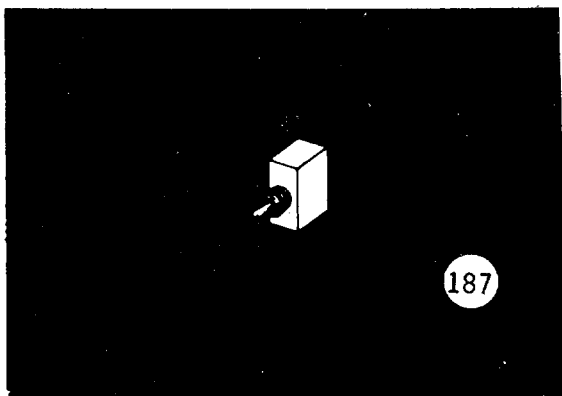
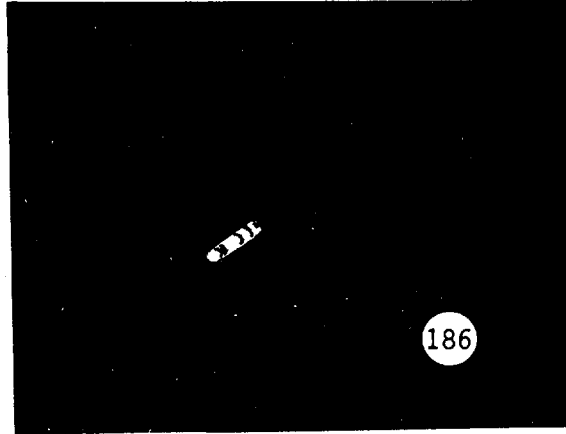
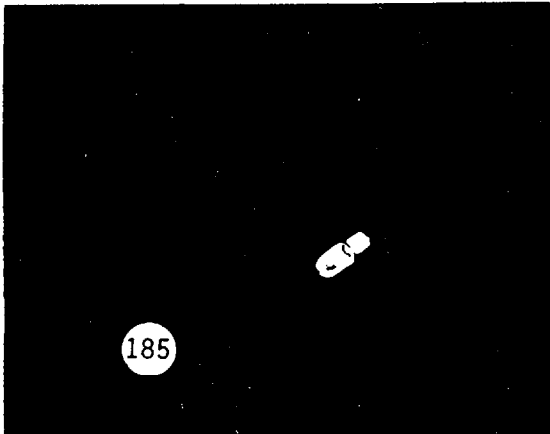

(1) ILLUS NO.	(2) NATIONAL STOCK NUMBER	(3) DESCRIPTION FSCM AND PART NUMBER	(4) USABLE ON CODE U/M	(5) QTY RQR
		The following 4 items are u/o Delaval Gens. Sensors Modular Receiver		
185	6240-00-763-7744	Lamp (96906) MS25237	EA	3
186	5920-00-665-2881	Fuse, Lamp (04034) 15483	EA	3
187	5930-00-110-7651	Switch, Toggle (73559) HM-25A	EA	1
188	5950-01-039-7145	Transformer (04034) 37031	EA	1

SECTION III. BASIC ISSUE ITEMS LIST (CONTINUED).

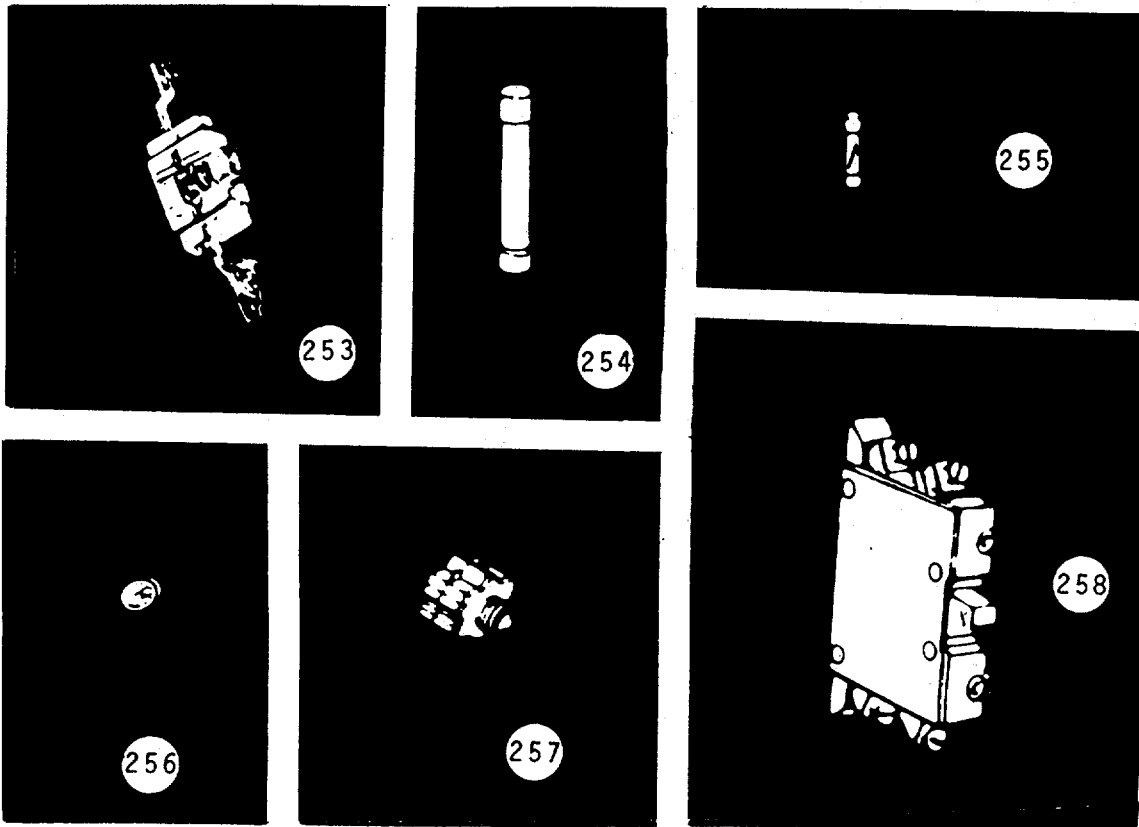

(1) ILLUS NO.	(2) NATIONAL STOCK NUMBER	(3) DESCRIPTION FSCM AND PART NUMBER	(4) USABLE ON CODE U/M	(5) QTY RQR
253	5930-00-421-6208	Contact (27191) D26MPR	EA	20
254	5920-01-090-0425	Fuse (27191) 611-562	EA	4
255	5920-01-019-6523	Fuse (27191) 611-564	EA	4
256	6240-00-110-4497	Lamp (27191) 28-1022	EA	11
257	6240-01-043-8549	Transformer (27191) 42-2672	EA	1
258	5945-00-138-5220	Interlock (27191) C320KB2	EA	4

SECTION III. BASIC ISSUE ITEMS LIST (CONTINUED).

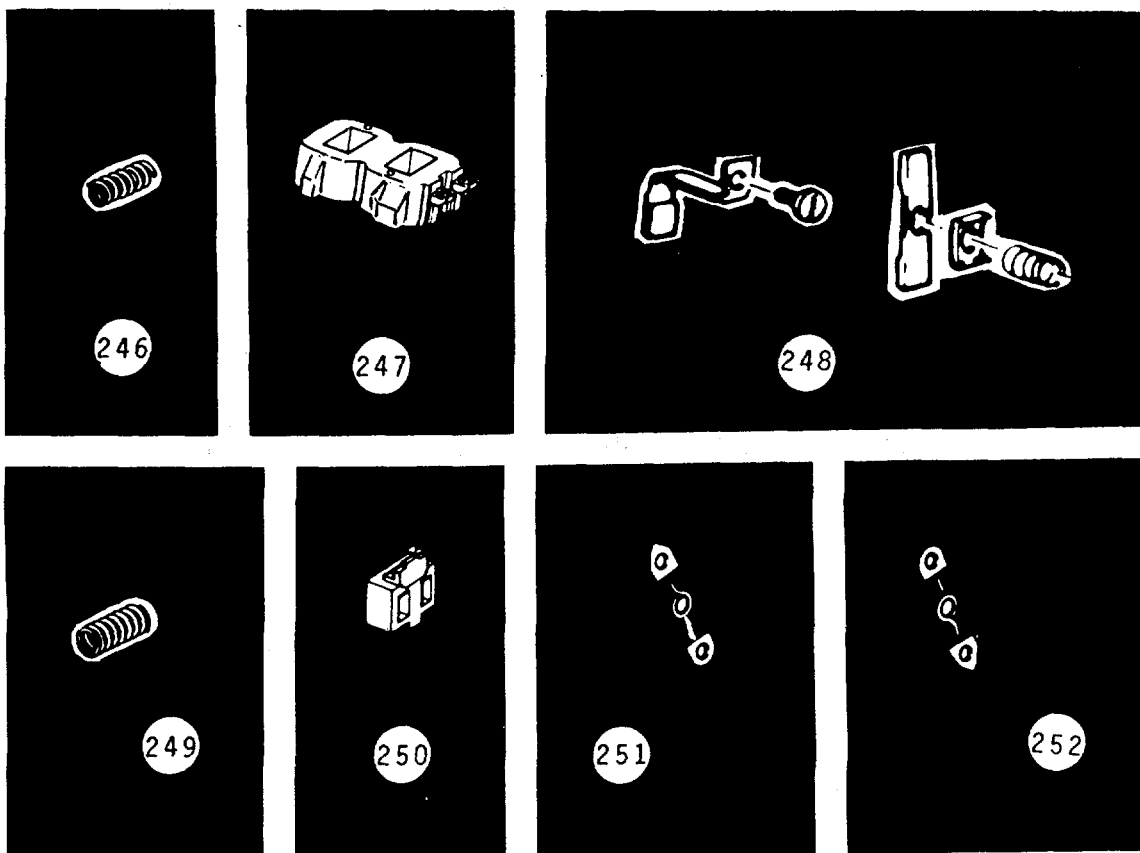

(1) ILLUS NO.	(2) NATIONAL STOCK NUMBER	(3) DESCRIPTION FSCM AND PART NUMBER	(4) USABLE ON CODE U/M	(5) QTY RQR
246	5360-00-438-8671	Spring, Retaining, Coil (27191) 69-2740	EA	10
247	5950-01-031-3205	Coil, Shunt (440V) (27191) 9-1889-20	EA	2
248	5999-00-318-2670	Renewal Set (27191) 6-22-2	EA	4
249	5360-00-760-7331	Spring, Arm, Frame (27191) 69-2507	EA	6
250	5950-00-121-2796	Coil, Shunt (110V) (27191) 9-1887-17	EA	1
251	5945-00-520-5580	Coil, Heater (27191) H1021	EA	4
252	5950-01-039-7162	Coil, Heater (27191) H1034	EA	4

SECTION III. BASIC ISSUE ITEMS LIST(CONTINUED).

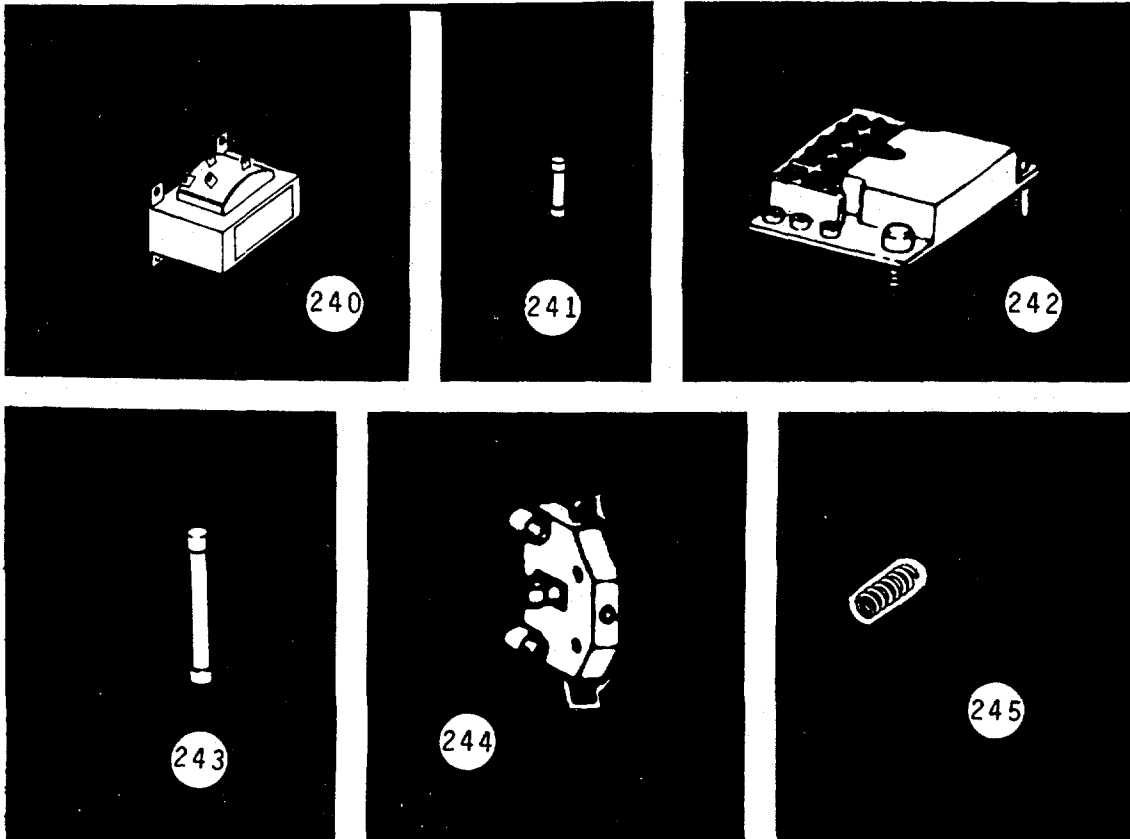

(1) ILLUS NO.	(2) NATIONAL STOCK NUMBER	(3) DESCRIPTION FSCM AND PART NUMBER	USABLE ON CODE	(4) U/M	(5) QTY RQR
240	5930-00-907-9461	Transformer, 250V (27191) 10942H55A		EA	2
241	5920-00-984-4428	Fuse 10A 250V (27191) 44-861		EA	4
242	6625-01-039-9975	Timer (on Delay) (27191) D26MTE		EA	2
243	5920-00-229-5236	Fuse 30A 600V (27191) 611-683		EA	4
244	5945-01-052-6222	Interlock (27191) C320KB8		EA	1
245	5360-00-438-8668	Spring, Push Bar Return (27191) 69-2741		EA	10

SECTION III. BASIC ISSUE ITEMS LIST (CONTINUED).

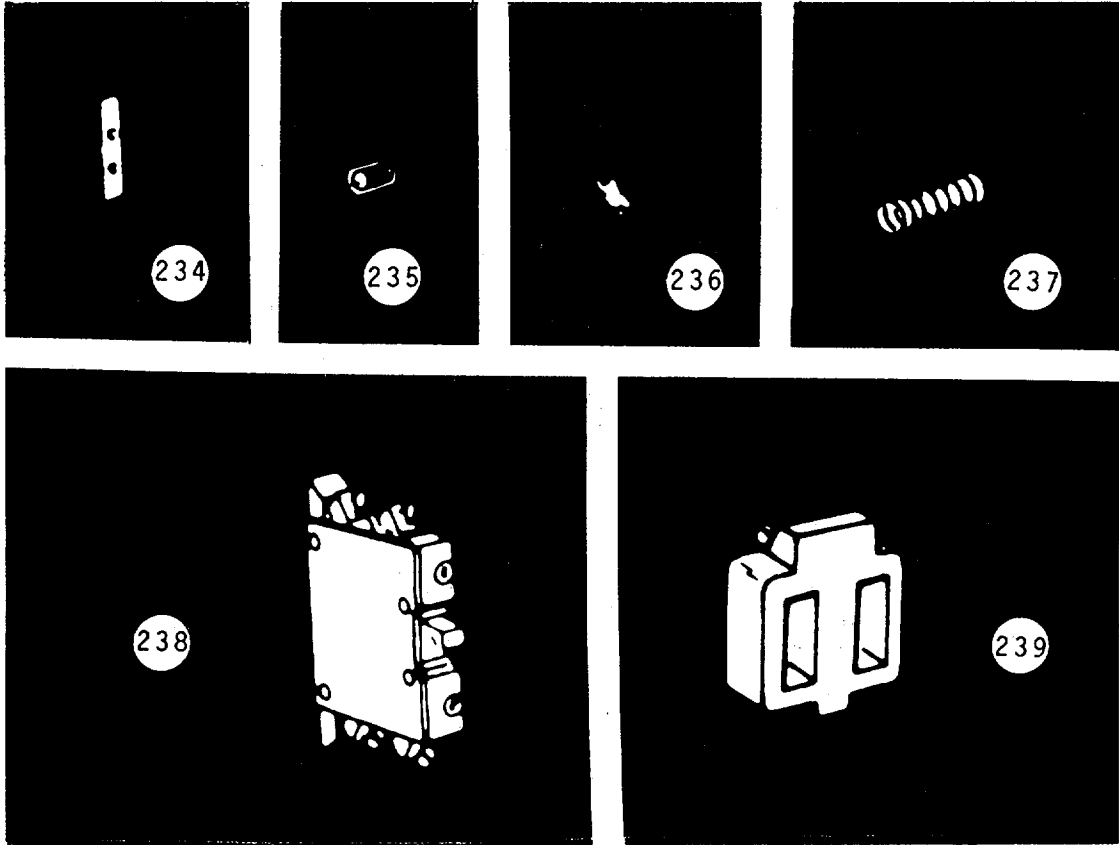

(1) ILLUS NO.	(2) NATIONAL STOCK NUMBER	(3) DESCRIPTION FSCM AND PART NUMBER	(4) USABLE ON CODE U/M	(5) QTY RQR
234	5999-00-482-2196	Contact, Moveable (27191) 23-3706	EA	6
235	5360-00-483-2334	Spring, Contact (27191) 69-2598	EA	6
236	5340-00-482-6985	Retainer, Spring (27191) 55-1950	EA	6
237	5360-00-483-2337	Spring, Helical (27191) 69-2692	EA	4
238	5945-00-138-5221	Interlock (27191) C320KB5	EA	2
239	5950-00-428-3217	Coil, Shunt (11OV) (27191) 9-1889-28	EA	2

SECTION III. BASIC ISSUE ITEMS LIST (CONTINUED).

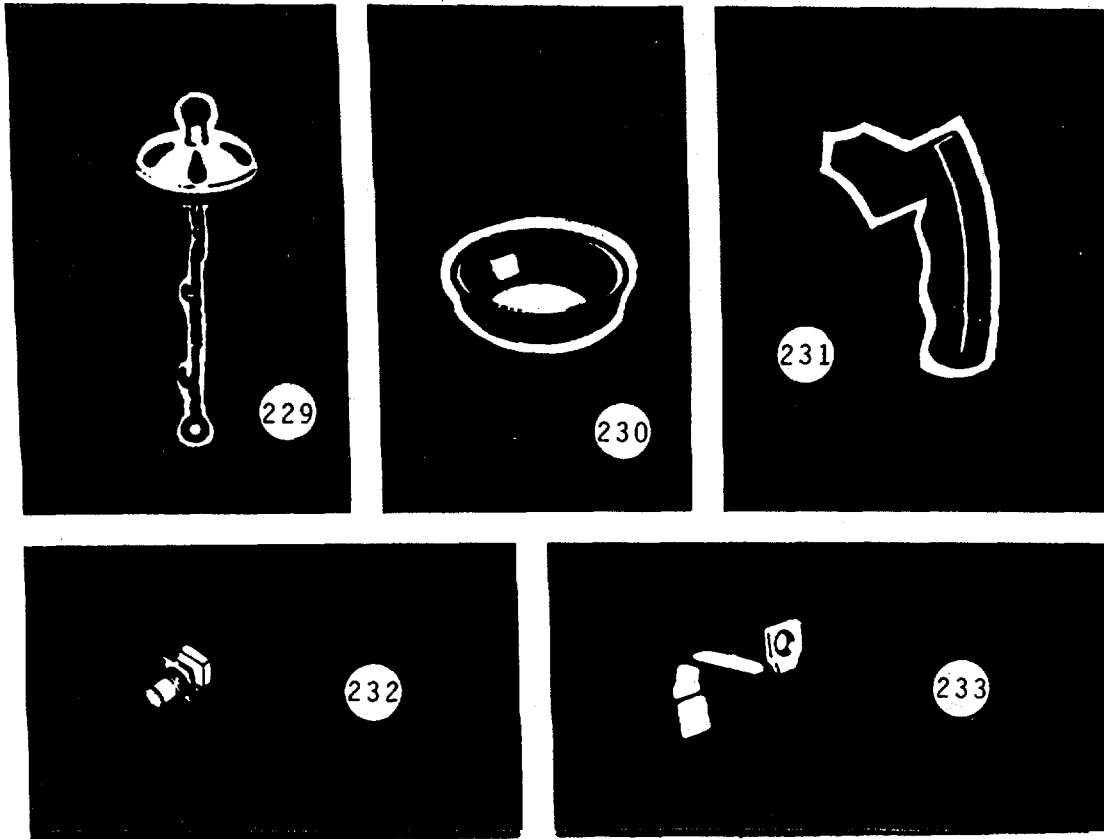

(1) ILLUS NO.	(2) NATIONAL STOCK NUMBER	(3) DESCRIPTION FSCM AND PART NUMBER	(4) USABLE ON CODE U/M	(5) QTY RQR
229	7310-01-041-1216	Filter, CRES (14718) 205301	EA	1
230	5325-01-041-9578	Bushing, Rubber (14718) 204000	EA	1
231	7310-01-044-5385	Handle (14718) 201000	EA	1
		The following 30 items are u/o various Cutler-Hammer Magnetic Controllers		
232	5930-00-615-2193	Block, Contact (27191) 10250T2	EA	2
233	5999-00-482-2195	Contact, Stationary (27191) 23-3470	EA	4

SECTION III. BASIC ISSUE ITEMS LIST (CONTINUED).

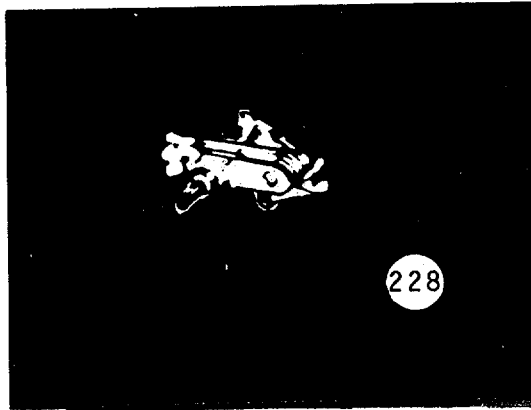
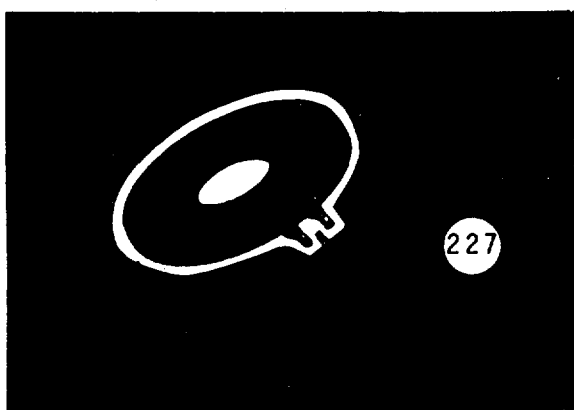
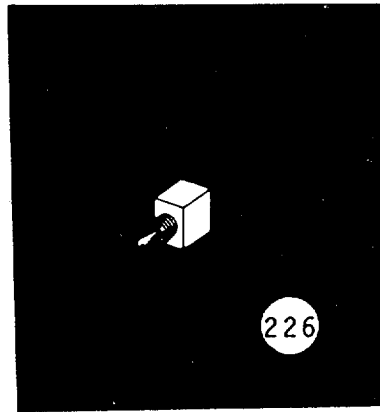
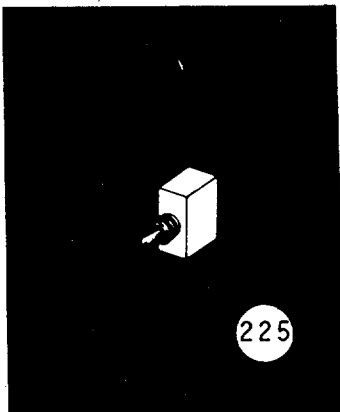
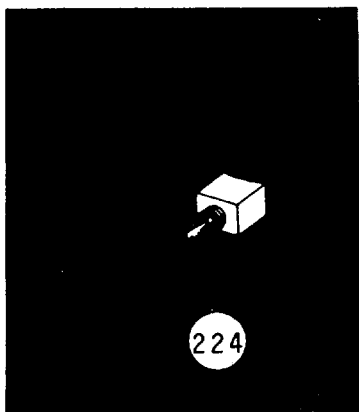

(1) ILLUS NO.	(2) NATIONAL STOCK NUMBER	(3) DESCRIPTION FSCM AND PART NUMBER	(4) USABLE ON CODE U/M	(5) QTY RQR
		The following 3 items are u/o Electrol Specialties Navigational Light Panel		
224	5930-00-615-9376	Switch, toggle (96906) MS35059-21	EA	1
225	5930-00-615-7883	Switch, toggle (96906) MS25068-21	EA	1
226	5930-00-655-1575	Switch, toggle (96906) MS35059-22	EA	1
		The following 5 items are u/o Cory Corp, Coffee Maker and 2 Burner Range		
227	7310-00-998-2811	Element (14718) 134829	EA	1
228	5930-00-018-9276	Switch (14718) 185200	EA	2

SECTION III. BASIC ISSUE ITEMS LIST (CONTINUED).

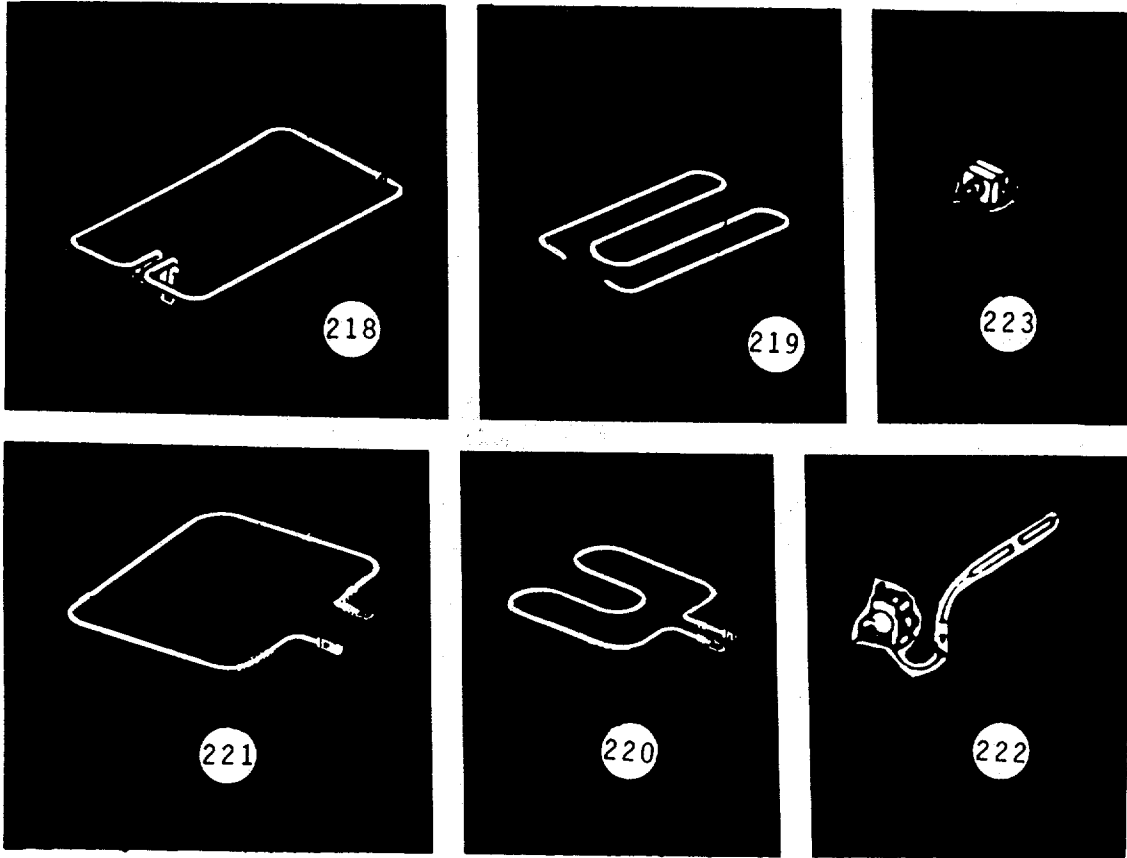

(1) ILLUS NO.	(2) NATIONAL STOCK NUMBER	(3) DESCRIPTION FSCM AND PART NUMBER	(4) USABLE ON CODE U/M	(5) QTY RQR
The following 6 items are u/o McGraw-Edison 440V Electric Range				
218	7310-01-093-3457	Element, Surface, Outer, 2750W, 460V (78770) 20MIE-30	EA	1
219	7310-01-093-3458	Element, Surface Inner, 2750W, 460V (78770) 20MIE-31	EA	1
220	7310-01-093-3459	Element, Oven, Inner, 900W, 460V (78770) PA-169-13	EA	1
221		Element, Oven Outer 900W, 460V (78770) PA-169-13	EA	1
222	5930-00-828-0004	Thermostat, Oven (78770) 18A18-74	EA	1
223	5930-00-784-8989	Switch, 3-Heat (78770) 4111A8733	EA	1

SECTION III. BASIC ISSUE ITEMS LIST (CONTINUED).

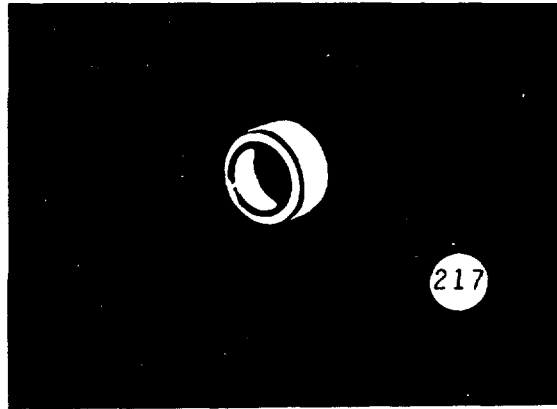
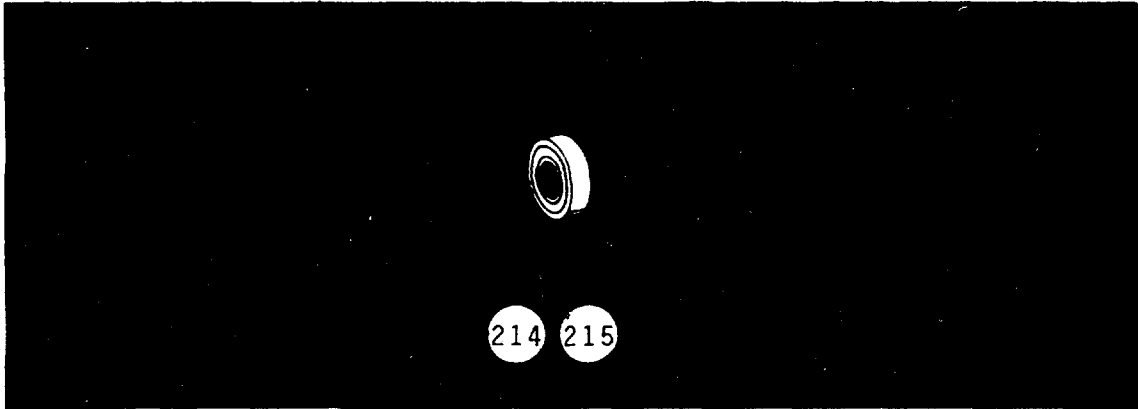

(1) ILLUS NO.	(2) NATIONAL STOCK NUMBER	(3) DESCRIPTION FSCM AND PART NUMBER	(4) USABLE ON CODE U/M	(5) QTY RQR
		The following 2 items are u/o Various Reliance Electric Co. Fan Motors		
214	3110-00-470-5800	Bearing, Ball (38740) 151248	EA	2
215	3110-00-470-5800	Bearing, Ball (38740) 151248	EA	2
		The following 2 items are u/o Reliance Electric Air Conditioner Compressor Motor		
216	3110-01-013-3762	Bearing, Ball (FE) (50380) 405850-43-E	EA	1
217	3110-01-013-3761	Bearing, Ball (BE) (50380) 405850-43-D	EA	1

SECTION III. BASIC ISSUE ITEMS LIST (CONTINUED).

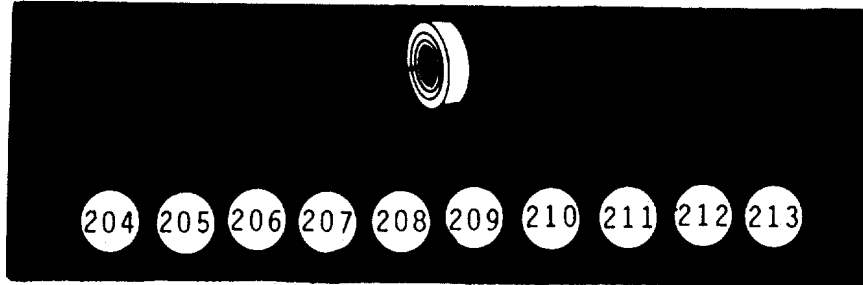

(1) ILLUS NO.	(2) NATIONAL STOCK NUMBER	(3) DESCRIPTION FSCM AND PART NUMBER	(4) USABLE ON CODE U/M	(5) QTY RQR
		The following 2 items are u/o Reliance Electric Fresh Water Pump.		
204	3110-00-321-9789	Bearing, Ball (FE) 405850-95-A	EA	1
205	3110-00-321-9789	Bearing, Ball (BE) 405850-95-A	EA	1
		The following 2 items are u/o Reliance Electric Air Cond. Unit Electric Motor.		
206	3110-01-023-7644	Bearing, Ball (FE) (50380) 405850-43-C	EA	1
207	3110-01-023-7644	Bearing, Ball (BE) (50380) 405850-43-C	EA	1
		The following 2 items are u/o Reliance Elec. Co. Reduction Gear Lube Oil Pump Motor.		
208	3110-00-321-9789	Bearing, Ball (FE) (50380) 405850-95-A	EA	1
209	3110-00-321-9789	Bearing, Ball (BE) (50380) 405850-95-A	EA	1
		The following 4 items are u/o Reliance Electric Flush Water Pump Motor.		
210	3110-01-092-0281	Bearing, Ball (FE) (50380) 416821-52D	EA	1
211	3110-00-280-3316	Bearing, Ball (BE) (50380) 416821-52F	EA	1
212	3110-00-321-9789	Bearing, Ball (FE) (50380) 405850-95-A	EA	1
213	3110-00-321-9789	Bearing, Ball (BE) (50380) 405850-95-A	EA	1

SECTION III. BASIC ISSUE ITEMS LIST (CONTINUED).

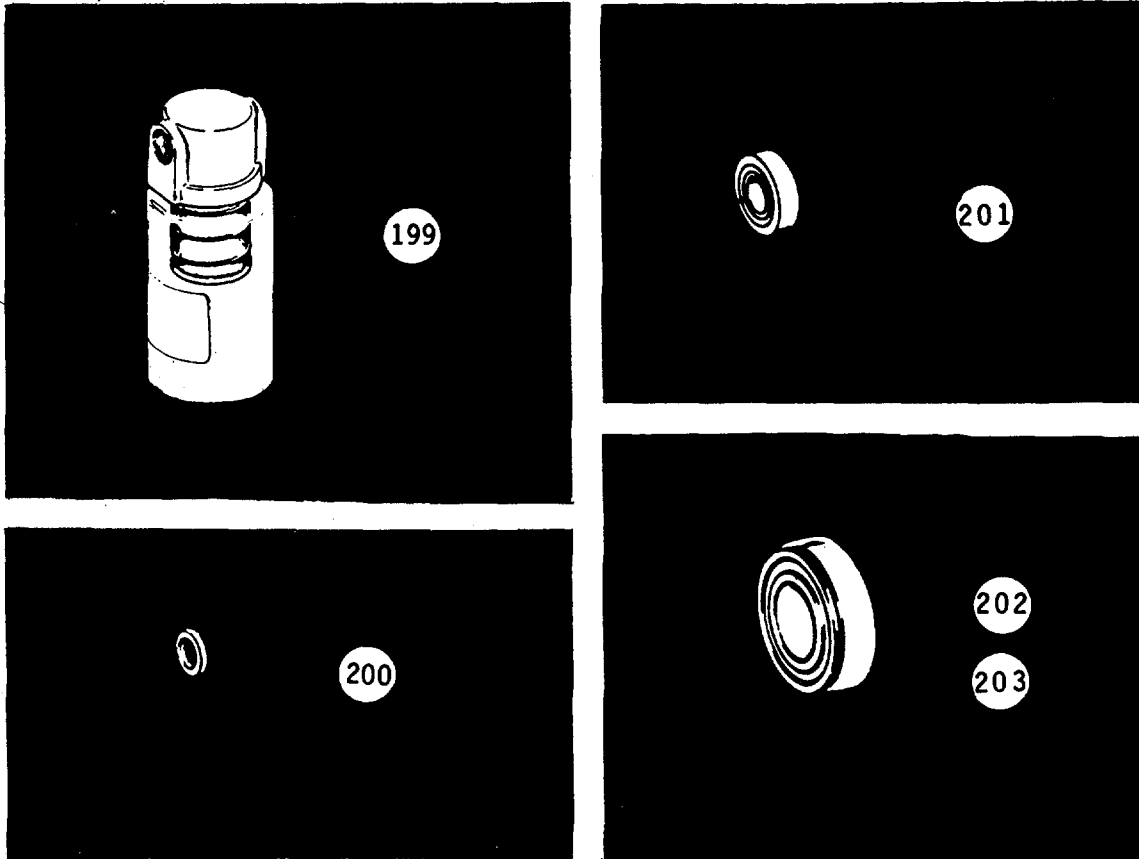

(1) ILLUS NO.	(2) NATIONAL STOCK NUMBER	(3) DESCRIPTION FSCM AND PART NUMBER	USABLE ON CODE	(4) U/M	(5) QTY RQR
199	4310-00-432-6969	Filter (98523) AD560		EA	1
200	5330-01-082-0566	Seal (98523) 920-1		EA	1
201	3110-00-554-5719	Bearing (31015) 65-7		EA	1
		The following 2 items are u/o Reliance Electric Fire Pump Motor			
202	3110-00-486-3123	Bearing, Ball (FE) (50380) 405850-95-D		EA	1
203	3110-00-486-3130	Bearing, Ball (BE) (50380) 405850-95-AH		EA	1

SECTION III. BASIC ISSUE ITEMS LIST (CONTINUED).

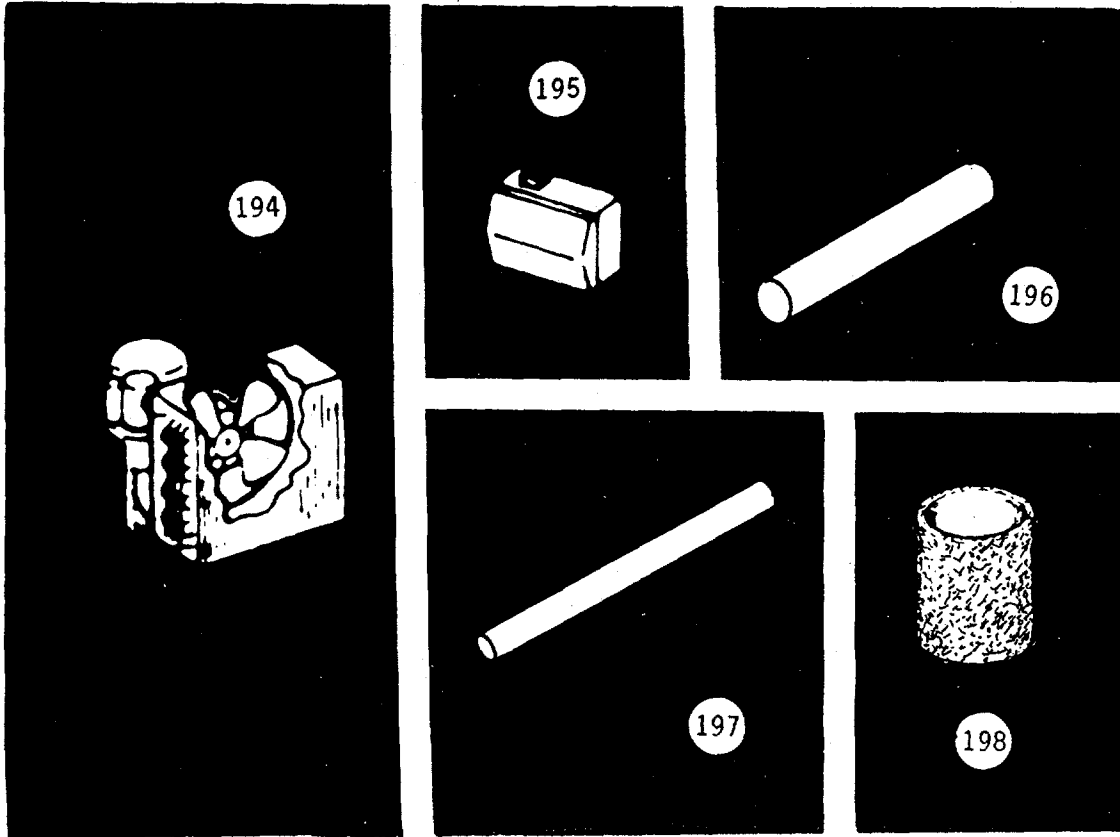

(1) ILLUS NO.	(2) NATIONAL STOCK NUMBER	(3) DESCRIPTION FSCM AND PART NUMBER	USABLE ON CODE	(4) U/M	(5) QTY RQR
194	6105-00-078-7588	Motor, Condensor Fan (Freezer) (25795) 3M285		EA	1
195	6645-01-068-6524	Timer, Defrost (45605) 8045-0		EA	1
		The following 6 items are u/o Jered Industries Sewage Plan			
196	4720-01-040-5385	Hose (98523) Z149B012		EA	1
197	4720-01-040-3178	Hose Assembly (98523) A149B014		EA	1
198	4310-00-353-5277	Filter (24123) D344B		EA	1

SECTION III. BASIC ISSUE ITEMS LIST (CONTINUED).

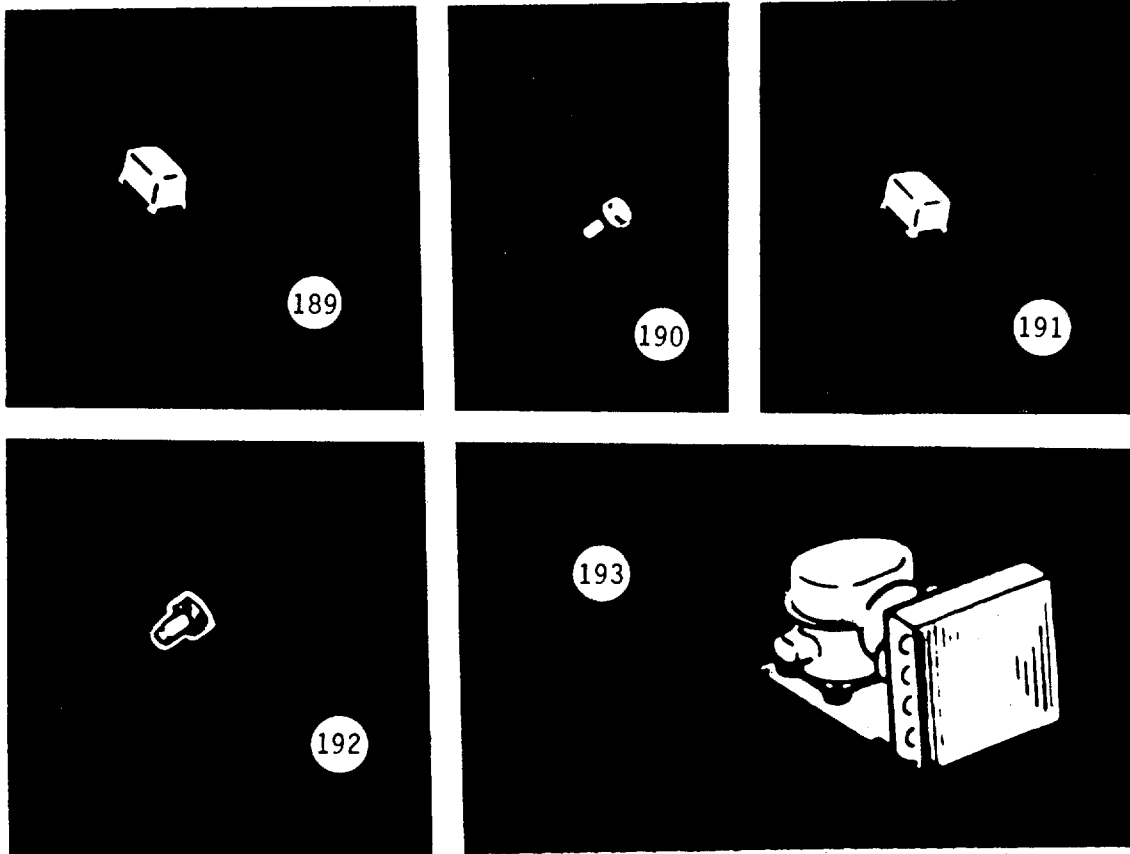

(1) ILLUS NO.	(2) NATIONAL STOCK NUMBER	(3) DESCRIPTION FSCM AND PART NUMBER	(4) USABLE ON CODE U/M	(5) QTY RQR
		The following 7 items are u/o Foster Refrigeration Co. Refrigerator Freezer		
189	5945-00-982-7728	Relay, Refrigerator (59431) 82684	EA	1
190	5945-01-050-0961	Relay, Freezer (59431) 82403	EA	1
191	5945-00-457-5368	Overload, Refrigerator (59431) 83458	EA	1
192	6105-00-937-5785	Overload, Freezer (59431) 83426	EA	1
193	6105-01-032-4705	Motor, Condensor Fan (Refrigerator) (59431) 87099A	EA	1

SECTION III. BASIC ISSUE ITEMS LIST (CONTINUED).

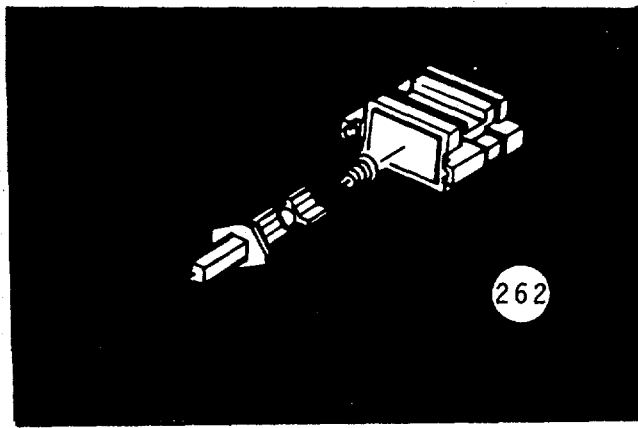
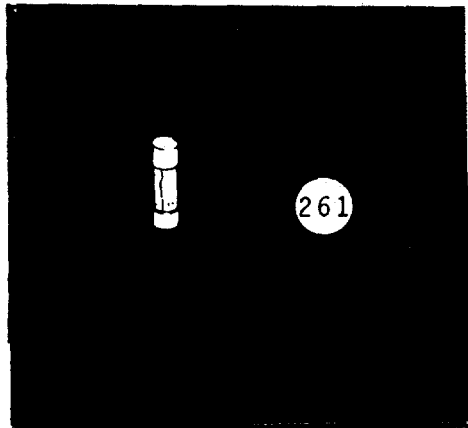
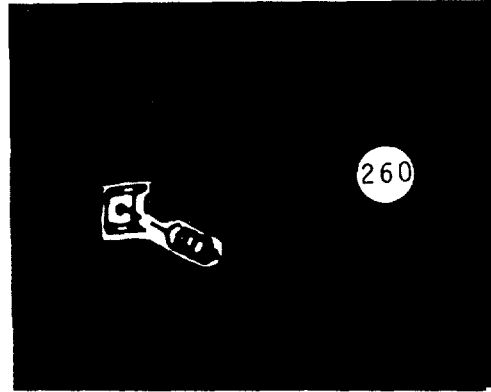
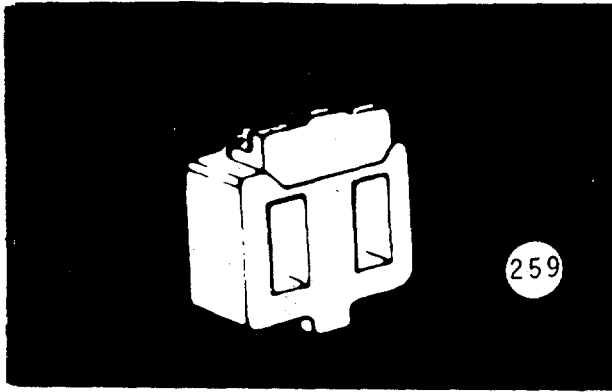

(1) ILLUS NO.	(2) NATIONAL STOCK NUMBER	(3) DESCRIPTION FSCM AND PART NUMBER	USABLE ON CODE	(4) U/M	(5) QTY RQR
259	5950-00-401-6781	Coil, Shunt (440V) (27191) 9-1887-19		EA	2
260	5999-00-487-7697	Renewal Set (27191) 6-25-2		EA	2
261	5920-00-367-9073	Fuse, 6A-250V (27191) 611-33		EA	4
		The following 6 items are u/o various Cutler-Hammer Pushbutton stations			
262	5930-00-538-0715	Element, N.O. (27191) 86-346-2		EA	3

SECTION III. BASIC ISSUE ITEMS LIST (CONTINUED).

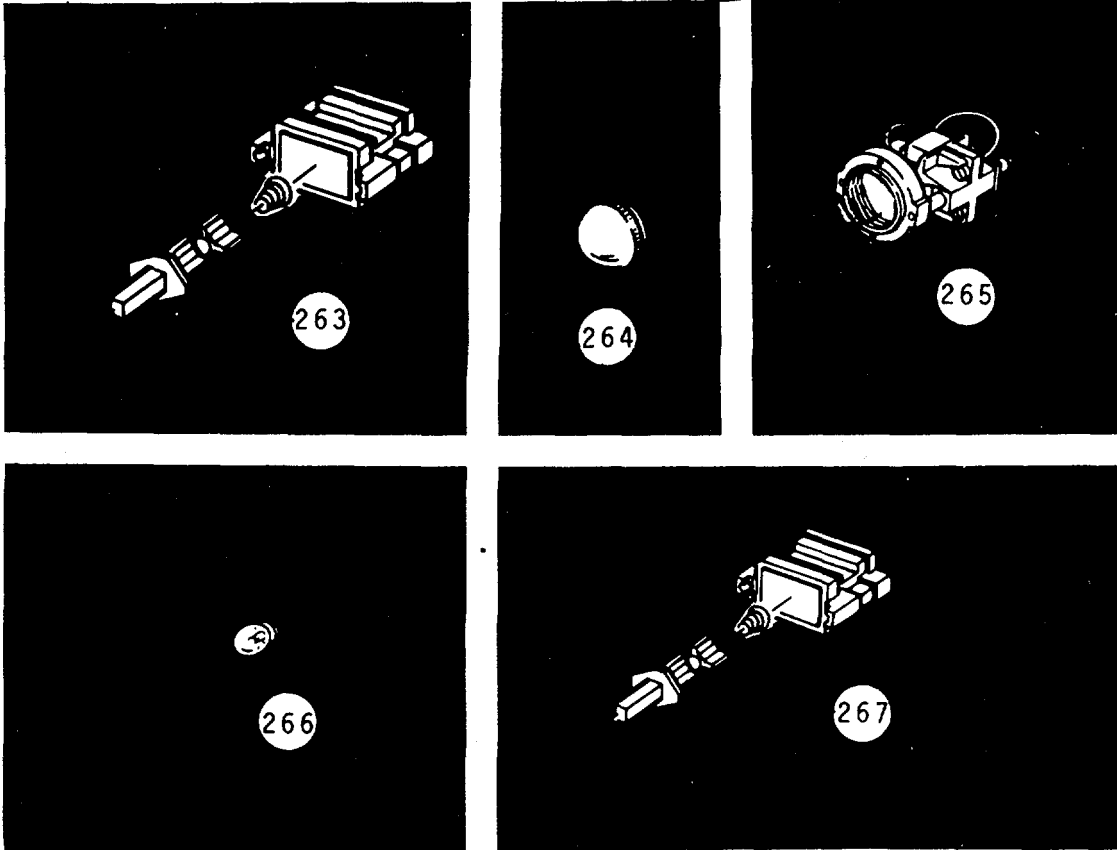

(1) ILLUS NO.	(2) NATIONAL STOCK NUMBER	(3) DESCRIPTION FSCM AND PART NUMBER	(4) USABLE ON CODE U/M	(5) QTY RQR
263	5930-00-636-0707	Element (27191) 86-346	EA	1
264	5950-00-828-0463	Lens (Red) (27191) 28-166	EA	1
265	6240-00-907-9451	Transformer (27191) 42-734-2	EA	1
266	5930-00-296-6431	Lamp (27191) 28-312	EA	1
267	5930-00-296-6431	Element (Pushbutton) (15605) 86-346-3	EA	1

SECTION III. BASIC ISSUE ITEMS LIST (CONTINUED).

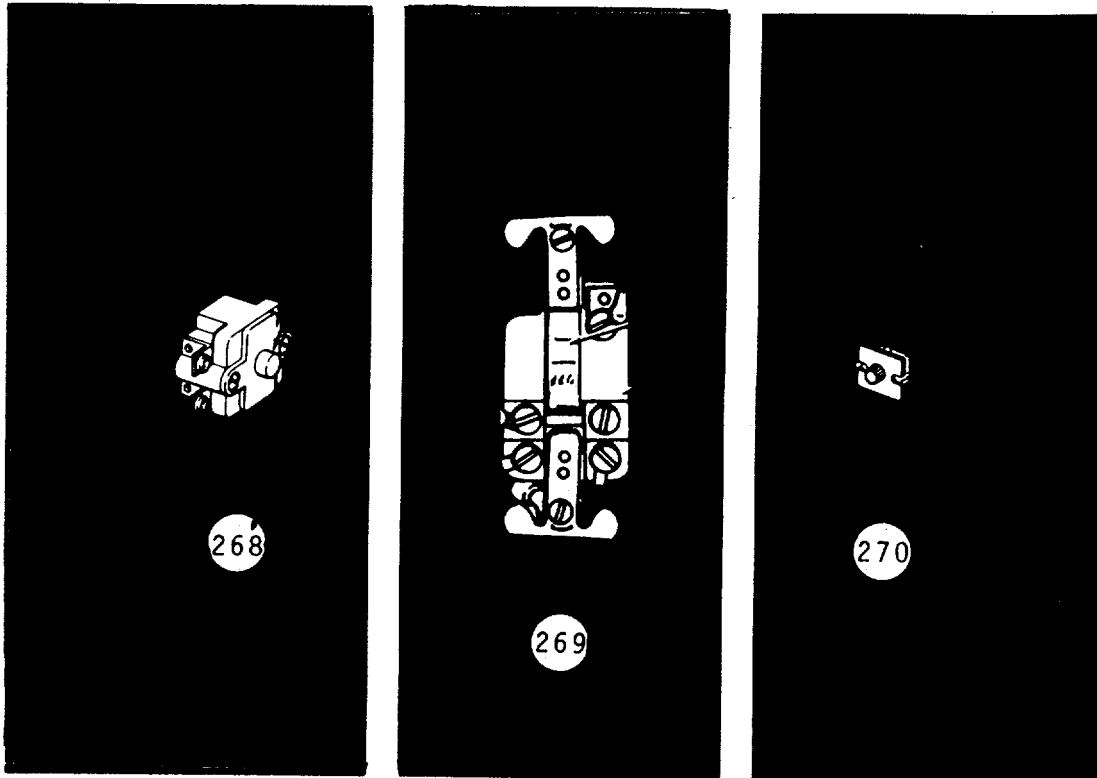

(1) ILLUS NO.	(2) NATIONAL STOCK NUMBER	(3) DESCRIPTION FSCM AND PART NUMBER	(4) USABLE ON CODE U/M	(5) QTY RQR
268	5930-00-446-4826	The following 1 item is u/o Cutler-Hammer Emergency Stop Break-Glass Stations Element (27191) 86-2639-3	EA	1
269	5930-00-056-4926	The following 1 item is u/o Cutler-Hammer Manual Starters Switch Mechanism (27191) 82-2084-7	EA	1
270	5930-00-922-4822	The following 5 items are u/o Stevens-Lee 5 Gallon Milk Dispenser Control, Temperature (49744) A10-935	EA	1

SECTION III. BASIC ISSUE ITEMS LIST (CONTINUED).

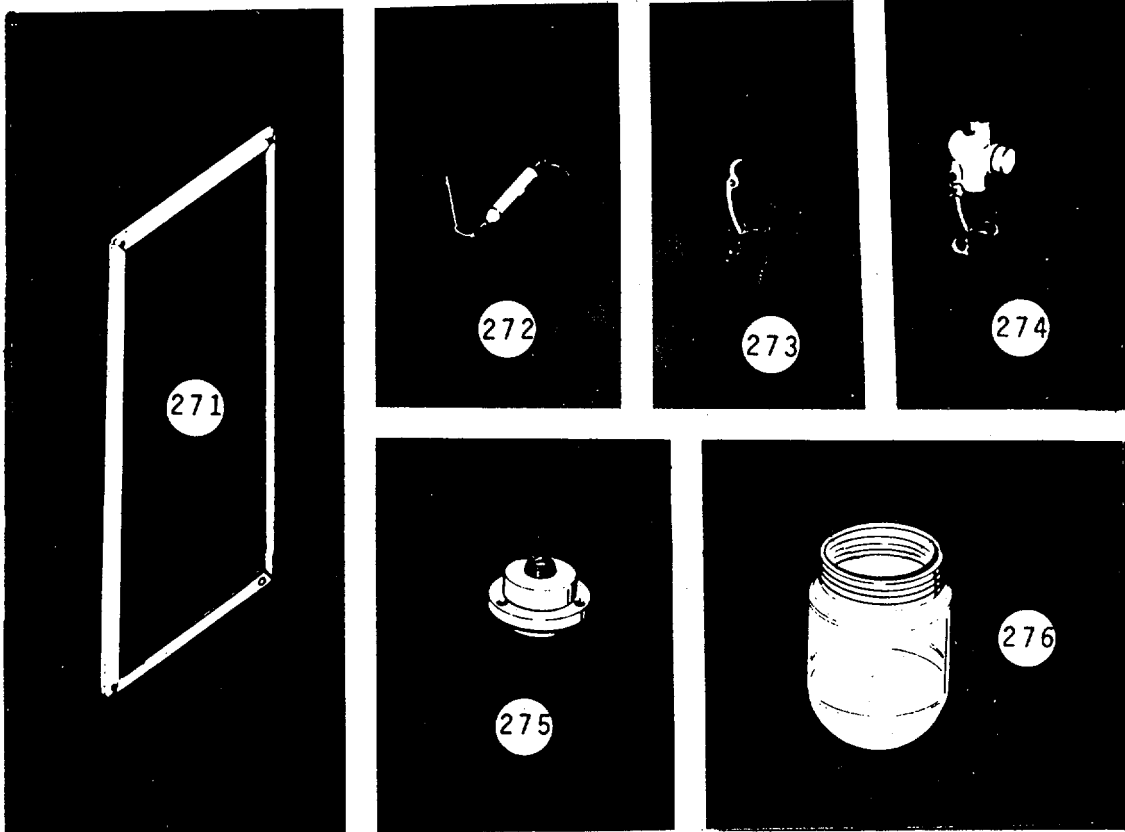

(1) ILLUS NO.	(2) NATIONAL STOCK NUMBER	(3) DESCRIPTION FSCM AND PART NUMBER	USABLE ON CODE	(4) U/M	(5) QTY RQR
271	5330-01-041-6158	Gasket, Door (12884) 20407		EA	1
272	4130-00-872-4929	Dryer (12844) 20013		EA	1
273	7310-01-045-0430	Valve, Arm (12884) 40248		EA	1
274	4110-00-911-2456	Valve Assy (12884) 40301		EA	1
		The following 2 items are u/o Benson Electric Ceiling Fixtures, Symbol 232			
275	6250-01-064-5720	Socket (75382) 130C		EA	2
276	6210-01-068-5101	Globe, Clear (76012) C40-38-325		EA	2

SECTION III. BASIC ISSUE ITEMS LIST (CONTINUED).

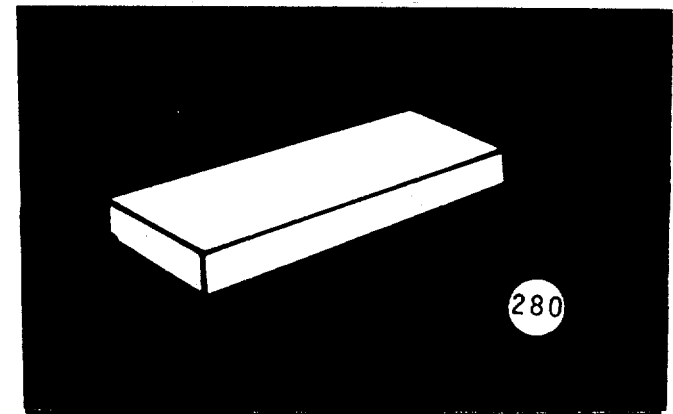
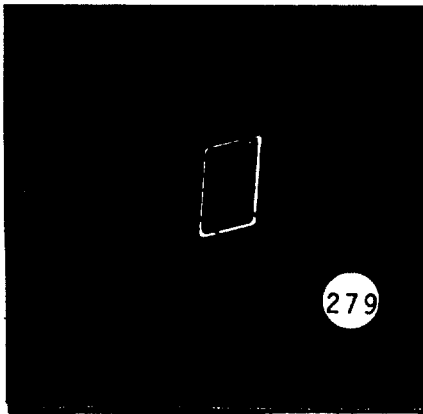
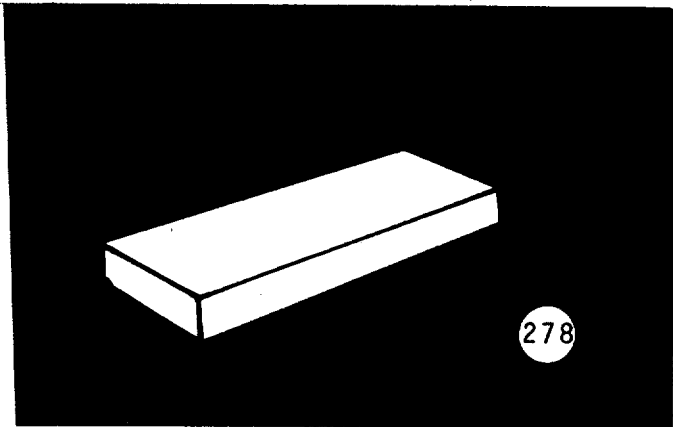
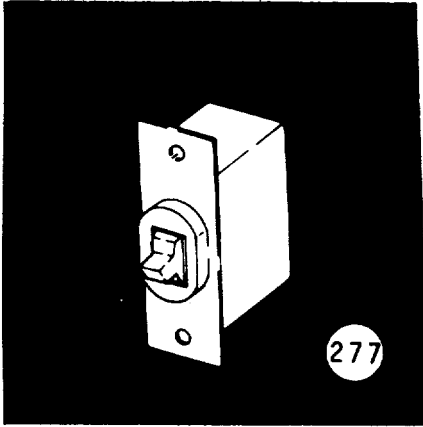

(1) ILLUS NO.	(2) NATIONAL STOCK NUMBER	(3) DESCRIPTION FSCM AND PART NUMBER	(4) USABLE ON CODE U/M	(5) QTY RQR
277	5930-01-088-8224	The following 1 item is u/o Light Fixtures Switch, Toggle DPST (70109) CL114-1-96	EA	6
278	5330-00-379-4327	The following 31 items are u/o Detroit Diesel MdL.1043-7000 (Prime mover for Anchor Winch) Gasket Kit, Engine Overhaul (72582) 5193114	EA	1
279	5330-00-425-5142	Gasket, Hand Hole Cover (72592) 5150020	EA	4
280	5330-00-166-8622	Gasket Kit, Cylinder Head Overhaul (72582) (5198676)	EA	1

SECTION III. BASIC ISSUE ITEMS LIST (CONTINUED).

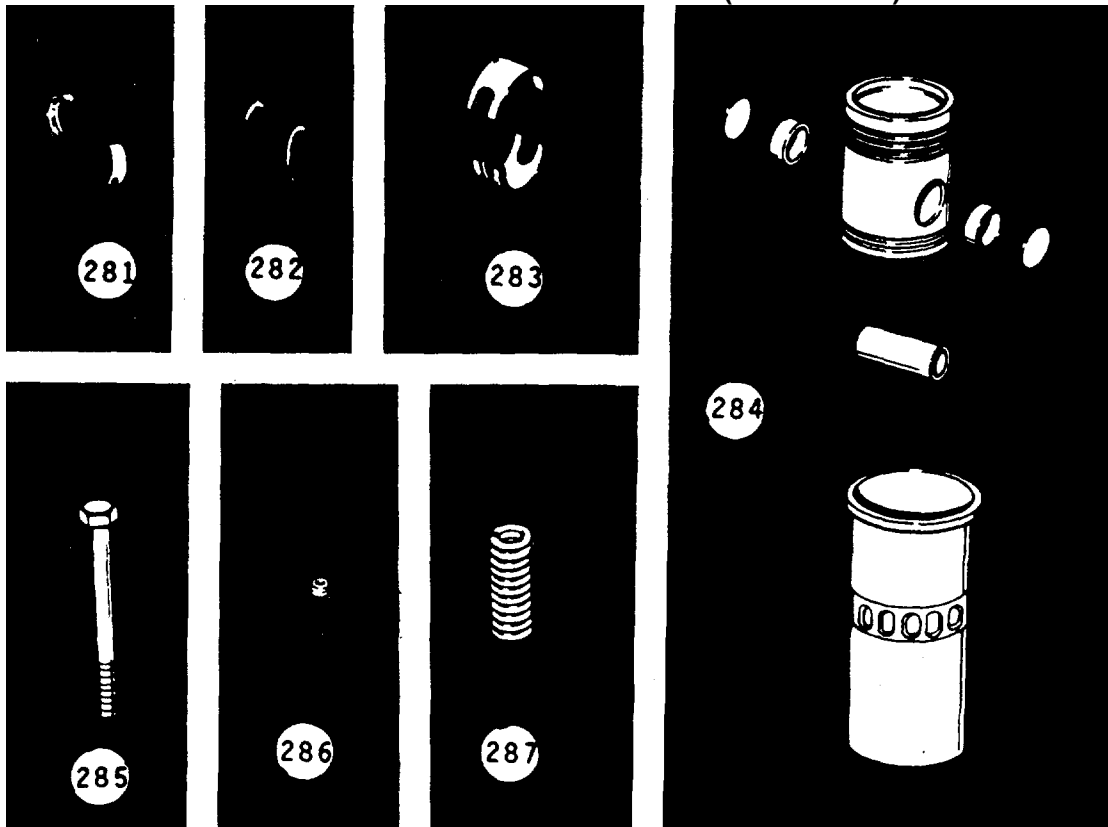

(1) ILLUS NO.	(2) NATIONAL STOCK NUMBER	(3) DESCRIPTION FSCM AND PART NUMBER	(4) USABLE ON CODE U/M	(5) QTY RQR
281	3120-00-662-8992	Shell Set, Main Bearing (72582) 5192874	EA	9
282	2815-00-511-2336	Washer, Thrust Main Bearing (72582) 5159353	EA	2
283	3120-00-662-8425	Shell Set, Con Rod (STD) (72582) 5192895	EA	4
284	2815-00-937-6571	Cylinder kit "N" Non-Auto (72582) 5149265	EA	8
285	4730-00-212-6331	Bolt, Rocker Shaft Bracket (72582) 5150325	EA	8
286	5310-00-270-7111	Nut, Lock, Push Rod (72582) 5151601	EA	8
287	5360-00-252-8444	Spring, Push Rod (72582) 5186858	EA	8

SECTION III. BASIC ISSUE ITEMS LIST (CONTINUED).

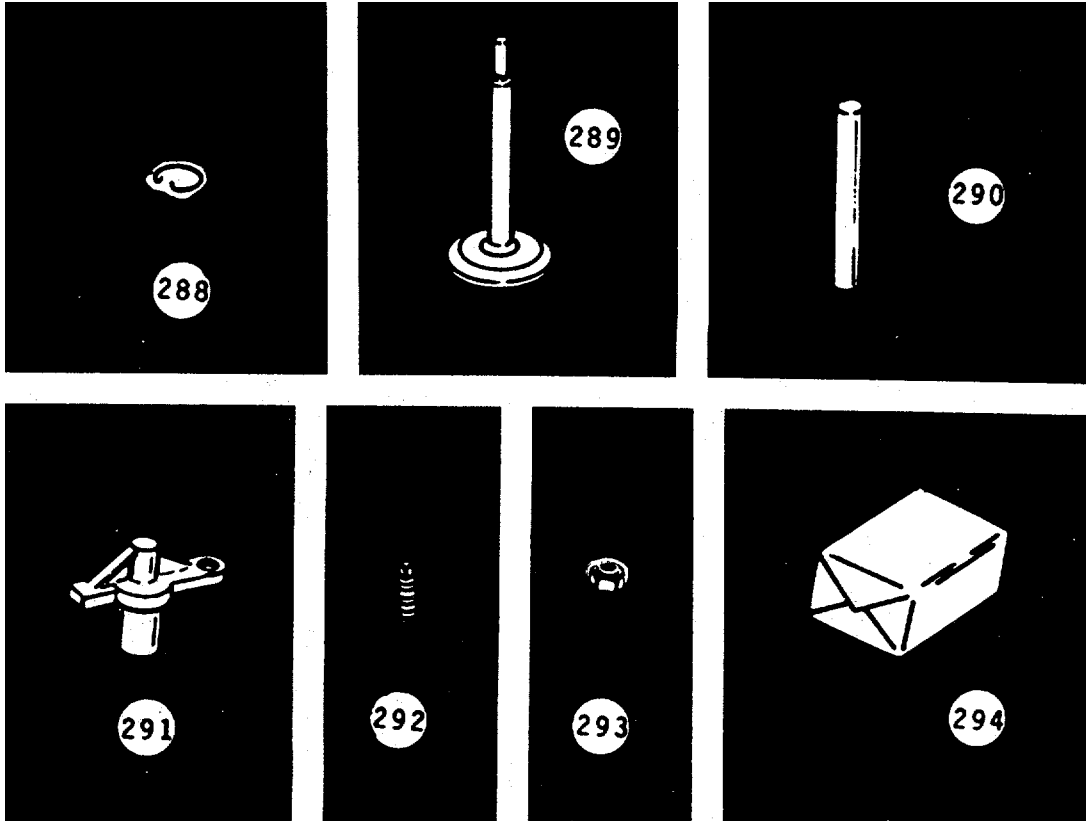

(1) ILLUS NO.	(2) NATIONAL STOCK NUMBER	(3) DESCRIPTION FSCM AND PART NUMBER	(4) U/M	(5) QTY RQR
288	5365-00-282-5031	Retainer, Push Rod (72582) 5150303	EA	8
289	2815-00-842-0859	Valve, Exhaust (72582) 5195167	EA	16
290	5360-01-893-3295	Spring, Exhaust Valve (72582) 5147347	EA	16
291	2815-00-731-4335	Bridge, Exhaust Valve (72582) 5117565	EA	2
292	2815-00-884-4803	Screw, Exhaust Valve Bridge Adjusting (72582) 5129101	EA	4
293	5310-00-270-7111	Nut, Exhaust Valve Bridge Screw Lock (72582) 5151601	EA	4
294	2910-00-808-2655	Overhaul kit, Fuel Pump (72582) 5199561	EA	2

SECTION III. BASIC ISSUE ITEMS LIST (CONTINUED).

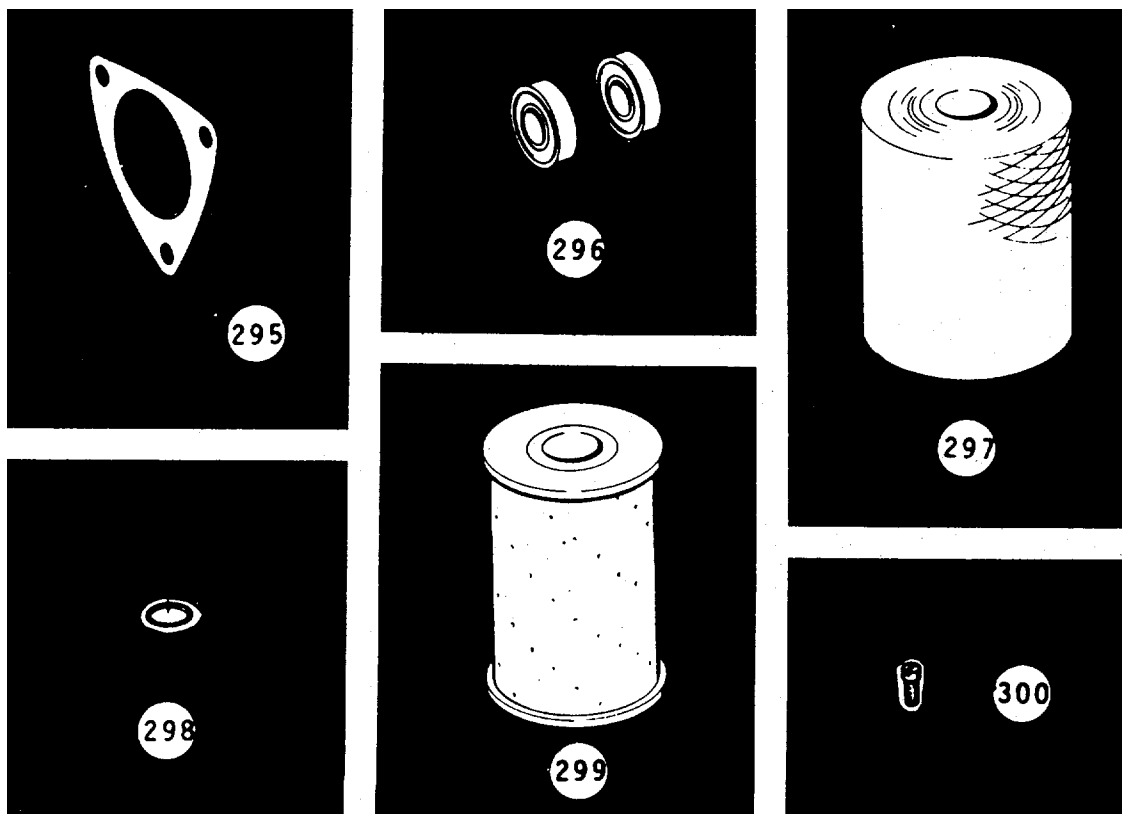

(1) ILLUS NO.	(2) NATIONAL STOCK NUMBER	(3) DESCRIPTION FSCM AND PART NUMBER	(4) USABLE ON CODE U/M	(5) QTY RQR
295	5330-00-212-6290	Gasket, Fuel Pump to Blower (72582) 5150193	EA	4
296	5330-00-178-3773	Seal, Oil, Fuel Pump (72582) 5230007	EA	2
297	2910-00-792-8985	Element, Fuel Strainer (72582) 5574961	EA	2
298	5330-00-930-3244	Gasket, Fuel Strainer Cover Screws (72582) 6435794	EA	6
299	2910-00-890-2436	Element, Fuel Filter (72582) 5573261	EA	2
300	5305-00-272-2080	Screw, Injector Control Tube Rack Lever (72582) 5176228	EA	10

SECTION III. BASIC ISSUE ITEMS LIST (CONTINUED).

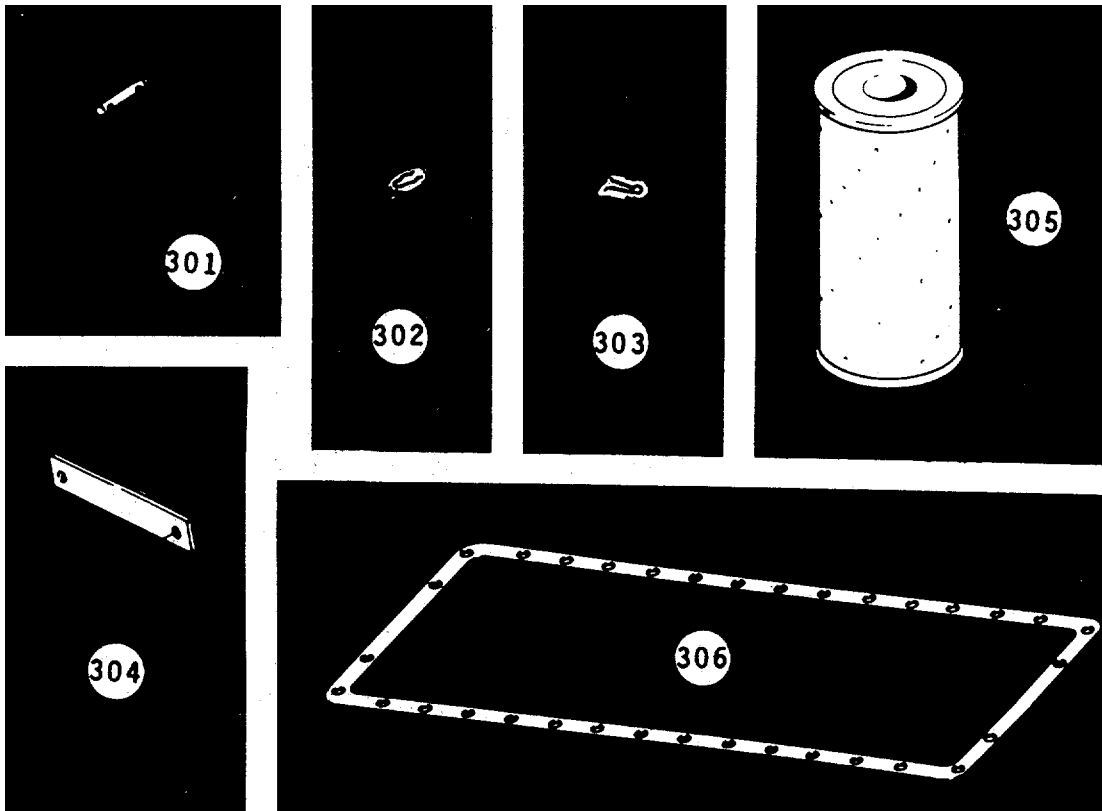

(1) ILLUS NO.	(2) NATIONAL STOCK NUMBER	(3) DESCRIPTION FSCM AND PART NUMBER	USABLE ON CODE	(4) U/M	(5) QTY RQR
301	5315-01-027-4955	Pin, Injector Control Tube to Gov Link (72582) 5147345		EA	4
302	5340-00-814-2583	Retainer, Injector Control Tube to Gov. link (72582) 142583		EA	4
303	5315-00-234-1619	Pin, Cotter (96906) MS24665-170		EA	4
304	5365-00-597-7348	Shim, Oil, Pump, .003 (72582) 5176119		EA	4
305	2940-00-141-9026	Element, Lube Oil Filter By-Pass (72582) 5572425		EA	20
306	5330-00-383-8661	Gasket, Oil Pan (4 cyl) (72582) 5150116		EA	2

SECTION III. BASIC ISSUE ITEMS LIST (CONTINUED).

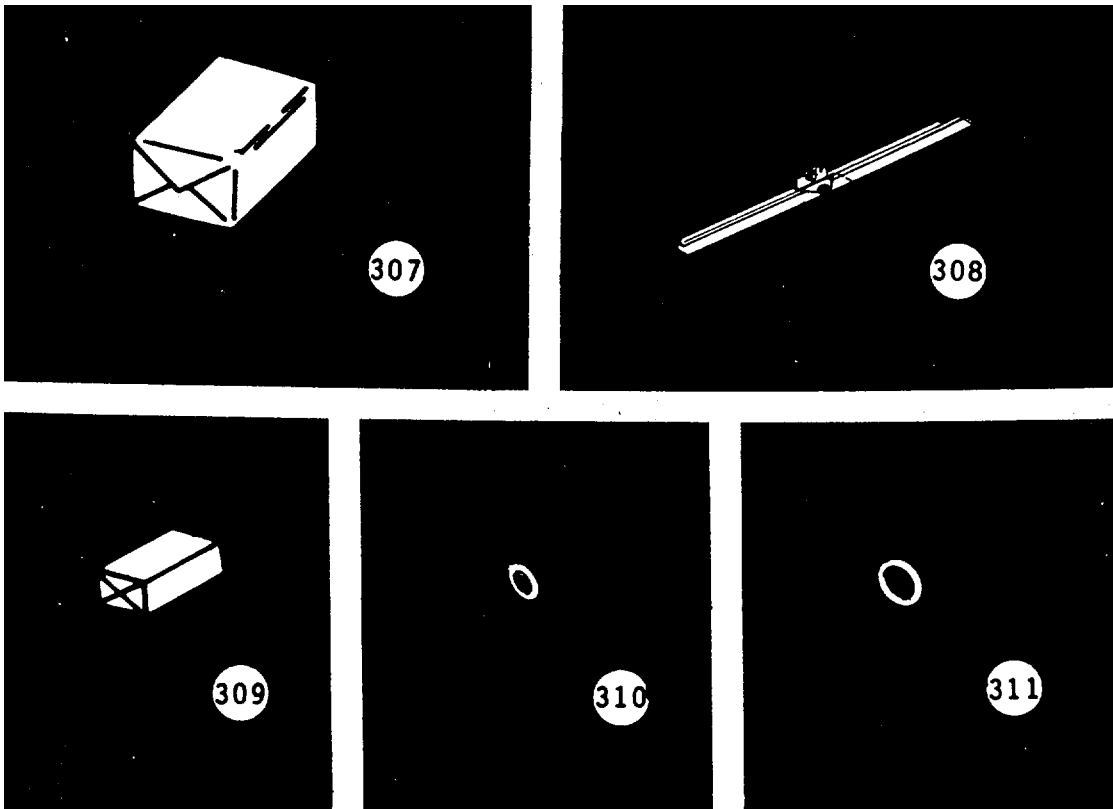

(1) ILLUS NO.	(2) NATIONAL STOCK NUMBER	(3) DESCRIPTION FSCM AND PART NUMBER	USABLE ON CODE	(4) U/M	(5) QTY RQR
307	2930-00-986-4068	Reconditioning Kit, (FW) Pump (Std with Carbon Seal) (72582) 5198307 The following one item is u/o Singer-Kearfott Windshield Wiper		EA	2
308	2090-00-708-2022	Blade, Wiper (81100) N56-14 The following 24 items are u/o J. W. Grimstead Hydraulic Power Unit		EA	2
309	5330-01-040-7776	(Racine Hyd) Seal Kit (77521) 723199		EA	1
310	5330-00-914-0795	(Racine Hyd) "0" Ring (77521) 401273		EA	1
311	5330-00-121-2825	(Racine Hyd) "0" Ring (77521) 406270		EA	2

SECTION III. BASIC ISSUE ITEMS LIST (CONTINUED).

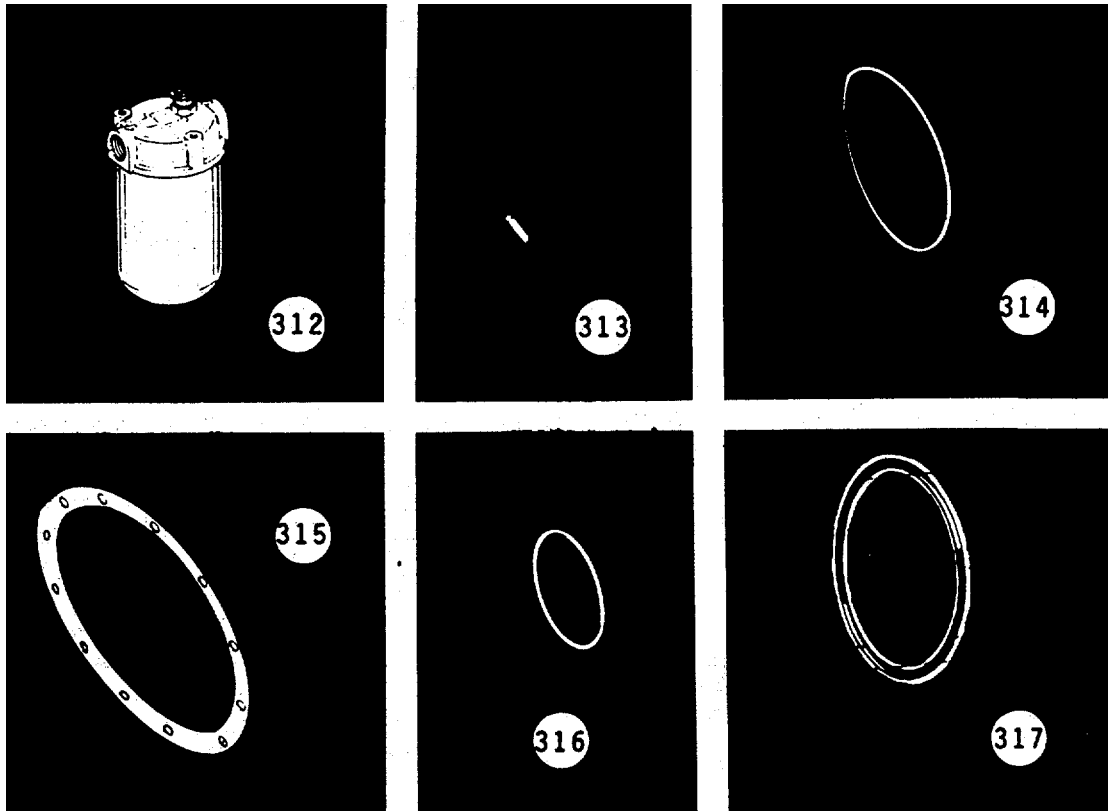

(1) ILLUS NO.	(2) NATIONAL STOCK NUMBER	(3) DESCRIPTION FSCM AND PART NUMBER	(4) USABLE ON CODE U/M	(5) QTY RQR
312	4330-01-019-8959	Element Filter 10 Micron (06816) HC9500SUJ4H	EA	1
313	5330-01-073-2870	Seal, Shaft (10522) A62305	EA	1
314	5330-00-349-9666	"O" Ring (10522) A60723	EA	1
315	5330-00-491-1520	Gasket (10522) B60528	EA	1
316	5330-01-040-7851	"O" Ring (10522) A62844	EA	1
317	5330-01-040-7778	Seal, Oil (10522) (A)-62471	EA	1

SECTION III. BASIC ISSUE ITEMS LIST (CONTINUED).

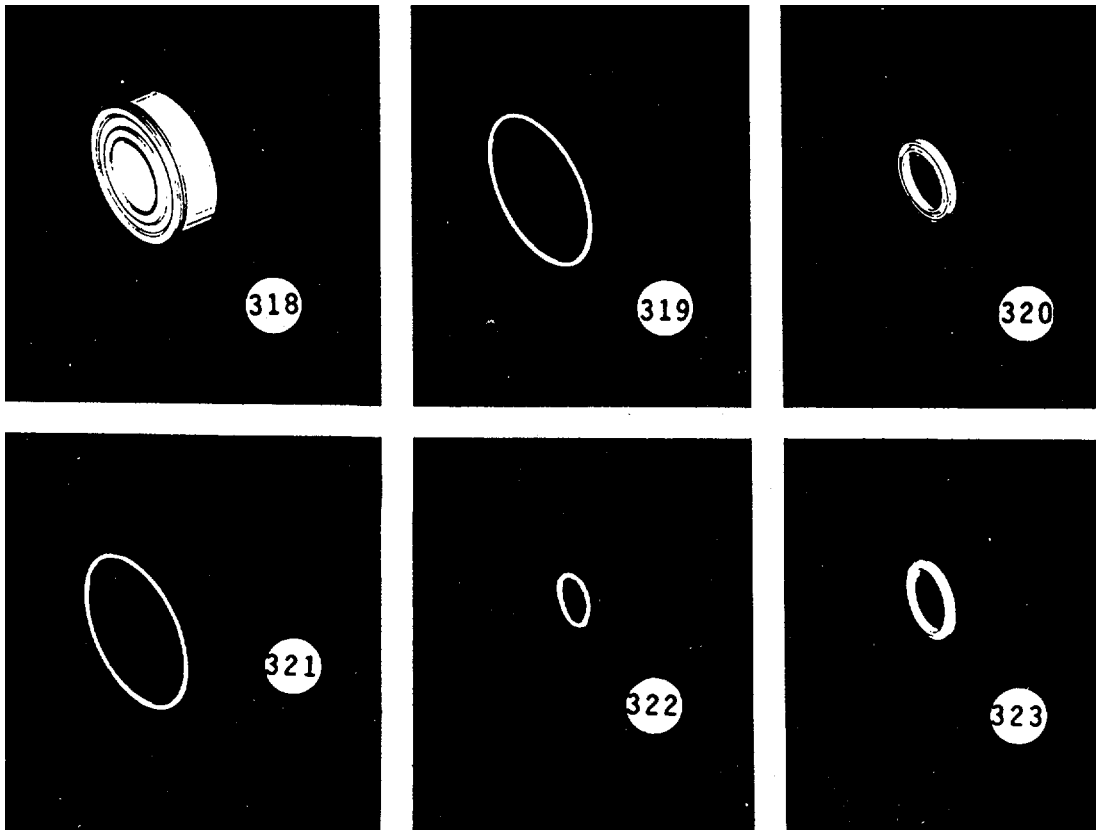

(1) ILLUS NO.	(2) NATIONAL STOCK NUMBER	(3) DESCRIPTION FSCM AND PART NUMBER USABLE ON CODE	(4) U/M	(5) QTY RQR
318	5330-01-026-4271	Seal, Shaft (10522) A-62892	EA	1
319	5330-01-093-7813	"O" Ring (10522) (A)-62463	EA	1
320	2040-00-946-0408	Packing, Piston (60285) 5030-3/4	EA	1
321	5330-00-760-4240	Scraper, Rod (60285) 5045-6-A	EA	1
322	5330-00-966-8692	"O" Ring, Body (60285) 5245-8	EA	1
323	5330-00-957-7680	"O" Ring, Piston Rod (60285) 5070-16	EA	1

SECTION III. BASIC ISSUE ITEMS LIST (CONTINUED).

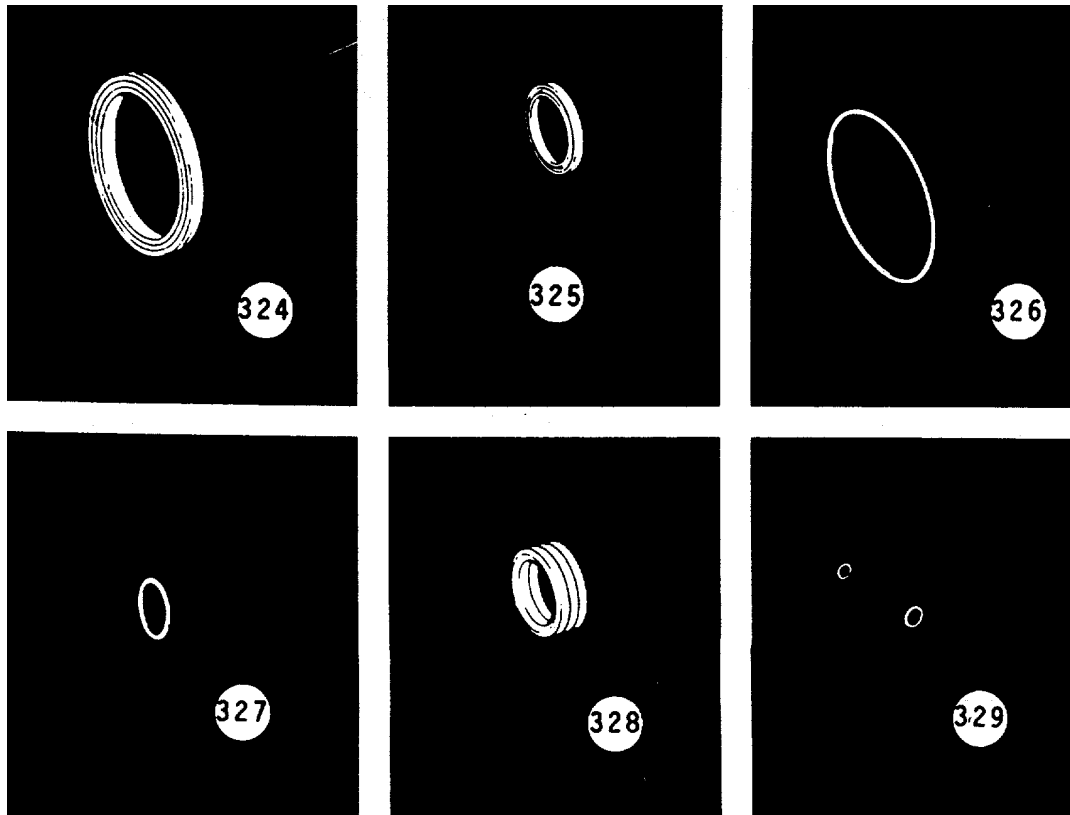

(1) ILLUS NO.	(2) NATIONAL STOCK NUMBER	(3) DESCRIPTION FSCM AND PART NUMBER	(4) USABLE ON CODE U/M	(5) QTY RQR
324	5330-00-946-0487	Packing, Rod (60285) 5080-60	EA	1
325	2030-00-878-0420	Scraper, Rod (60285) 5030-1-1/2	EA	1
326	5330-01-073-0906	"O" Ring, Body (60285) 5045018-A	EA	2
327	5330-00-904-8903	"O" Ring, Piston Rod (60285) 5245-12-1	EA	1
328	5330-01-041-9568	Packing, Rod (60285) 5070027	EA	3
329	5330-00-811-1629	"O" Ring, Adjustable Screw (60285) 5145-006	EA	2

SECTION III. BASIC ISSUE ITEMS LIST (CONTINUED).

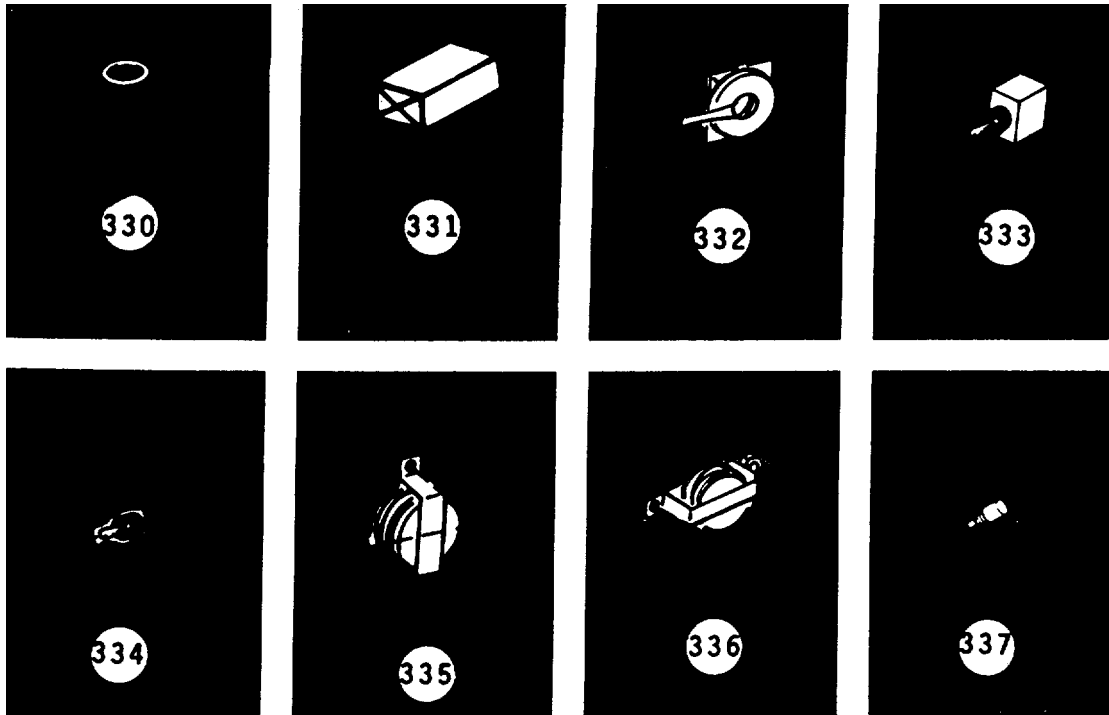

(1) ILLUS NO.	(2) NATIONAL STOCK NUMBER	(3) DESCRIPTION FSCM AND PART NUMBER	(4) USABLE ON CODE U/M	(5) QTY RQR
330	5330-01-041-1884	"O" Ring (Racine Hyd) (77521) 406216)	EA	4
331	5330-01-073-5006	Seal Kit (77521) 723394	EA	3
		The following 10 items are u/o Audio Equipped Tabet Mfr Co. Portable Electric Megaphones.		
332	5905-00-294-9097	Thermistor Assy (83186) A-815	EA	1
333	5930-00-552-9877	Switch, SPDT (40931) V3-32	EA	1
334	5930-00-556-9217	Switch (91929) 6AT-1	EA	1
.335	5950-01-039-7146	Transformer, Input (89829) 1T-1079	EA	1
336	5950-00-733-2823	Transformer, Driver (88829) DT 1080	EA	1
337	5830-01-039-7259	Control, Volume (88829) VR-5	EA	1

SECTION III. -BASIC ISSUE ITEMS LIST (CONTINUED).

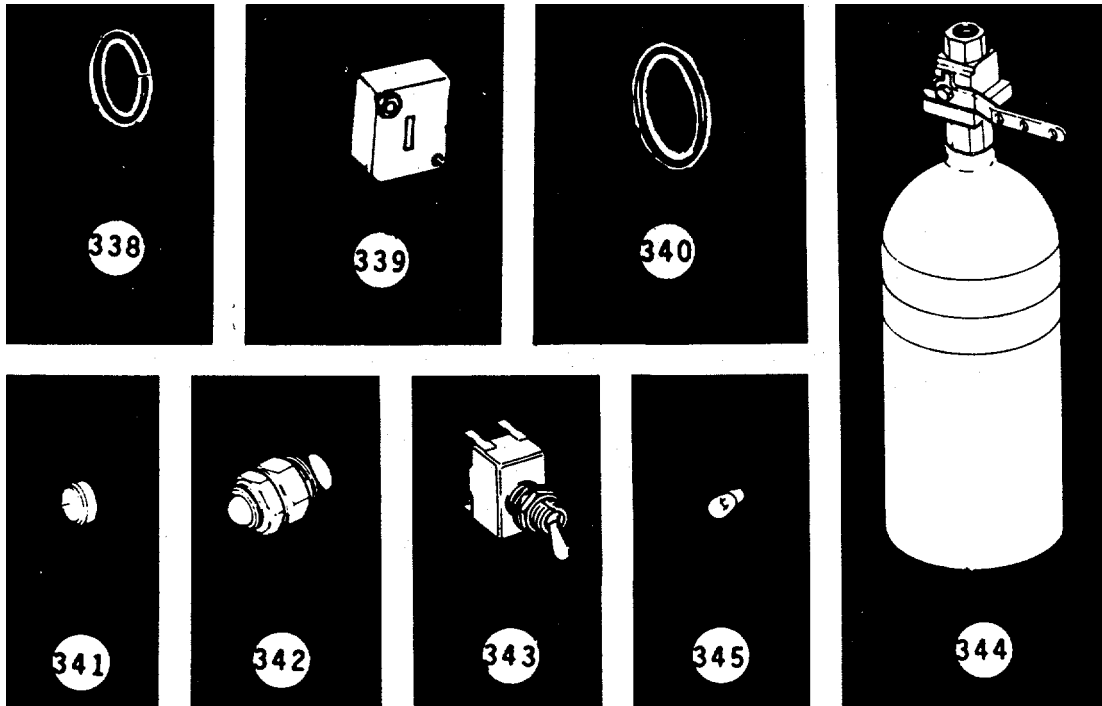

(1) ILLUS NO.	(2) NATIONAL STOCK NUMBER	(3) DESCRIPTION FSCM AND PART NUMBER	(4) U/M	(5) QTY RQR
338	5330-00-194-3733	"O" Ring, Drive Unit (88044) AN-6230-18	EA	1
339	5935-00-885-8598	Socket, Transistor (71785) 14T24324	EA	1
340	5330-00-993-3792	"O" Ring, Cover (88044) AN-6230-15	EA	1
341	5965-01-039-9060	Element, Microphone (88829) T8 The following 6 items are u/o Protector Inc. Fire Detection and Extinguishing System.	EA	1
342	6350-00-263-0588	Detector, Flame (11941) 30-2013-5	EA	2
343	5950-00-655-1575	Switch, Toggle (96906) MS35059-22	EA	1
344	4210-01-040-7619	Cylinder and Valve Assembly	EA	2
345	6240-00-491-0530	Lamp Incandescent (71744) 376-AS15	EA	10

SECTION III. BASIC ISSUE ITEMS LIST (CONTINUED).

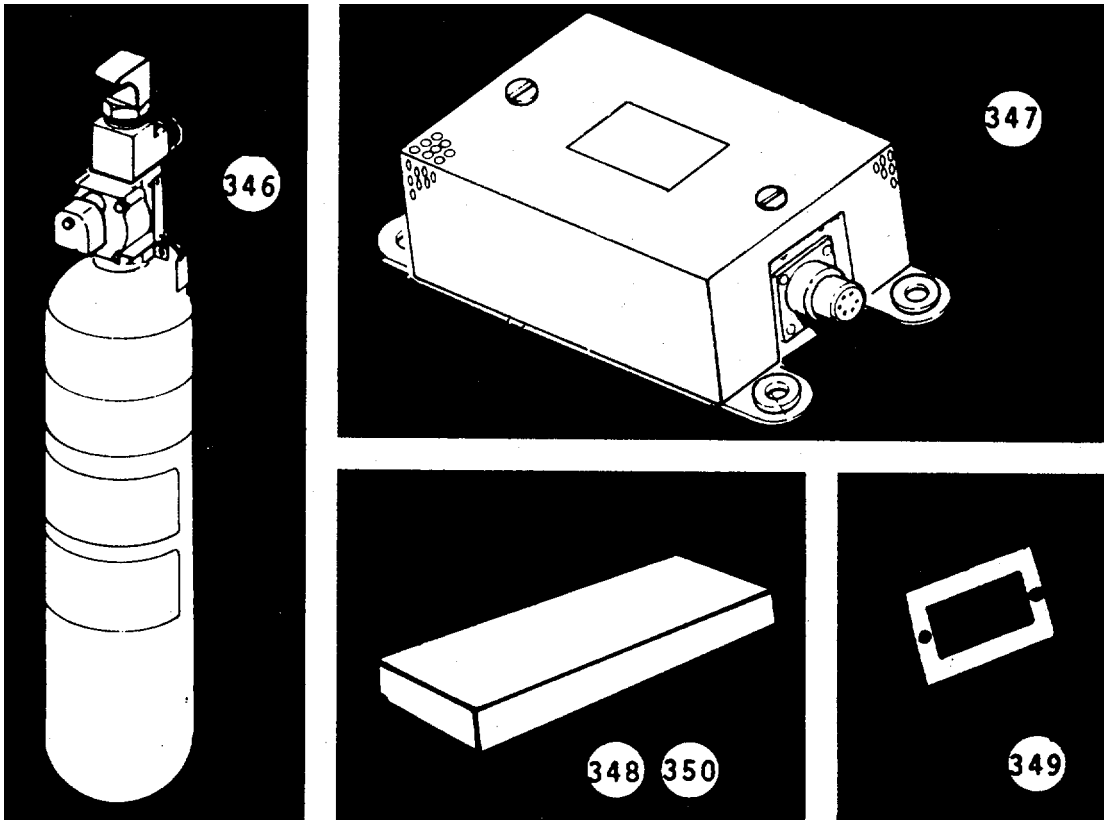

(1) ILLUS NO.	(2) NATIONAL STOCK NUMBER	(3) DESCRIPTION FSCM AND PART NUMBER	(4) USABLE ON CODE U/M	(5) QTY RQR
346	4210-01-042-0268	Cylinder and Valve/Nozzle (11941) 30-295-87	EA	1
347	4210-01-040-5556	Detector, Smoke (11941) 30-231-11 The following 6 items are u/o Detroit Diesel Main Propulsion Engines (DDAD Mdl 7122-7000). Some of these parts may also be u/o the Anchor Winch Engine and Generator Engines (DDAD Mdl 1043-7000 and 1033-7005).	EA	2
348	5330-00-837-8327	Gasket Kit, Engine Overhaul (72582)	EA	1
349	5330-00-866-9401	Gasket, Hand Hole Cover Small (WBP) 72582 5132924	EA	12
350	2815-00-839-6203	Gasket Kit, Cylinder Head Overhaul (72582) 5196382	EA	1

SECTION III. BASIC ISSUE ITEMS LIST (CONTINUED).

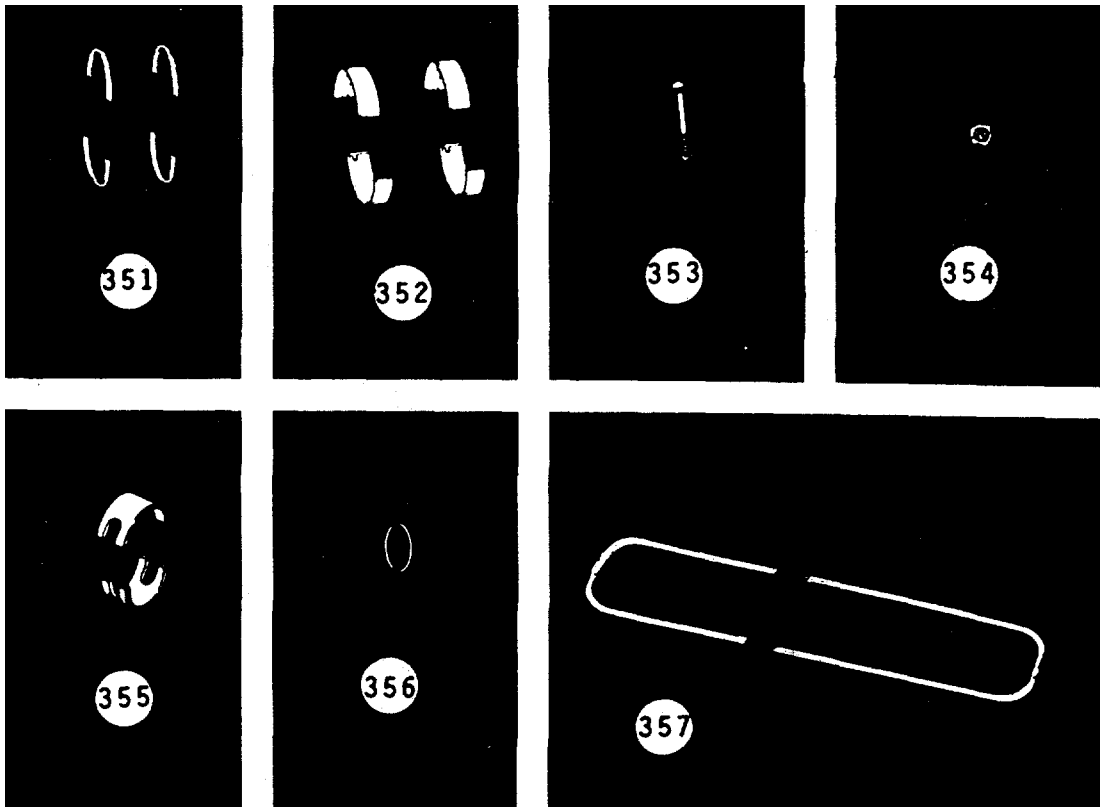

(1) ILLUS NO.	(2) NATIONAL STOCK NUMBER	(3) DESCRIPTION FSCM AND PART NUMBER	USABLE ON CODE	(4) U/M	(5) QTY RQR
351	2815-00-735-4202	Washer, Thrust, Main Bearing (72582) 5196319		EA	1
352	3120-00-903-0786	Shell Set, Main Bearing (STD) (72582) 5196319		EA	7
353	5360-00-136-9989	Bolt, Con Rod (72582) 5132383		EA	4
354	5310-00-841-5700	Nut, Con Rod Bolt (72582) 5117629		EA	6
355	3120-01-084-5357	Shell Set, Con Rod Bearing (STD) (72582) 5199946		EA	12
356	5330-00-792-9849	Seal, Oil, Camshaft (72582) 5116476		EA	2
357	5330-00-471-5618	Gasket, Rocker Cover (72582) 5143407		EA	2

SECTION III. BASIC ISSUE ITEMS LIST (CONTINUED).

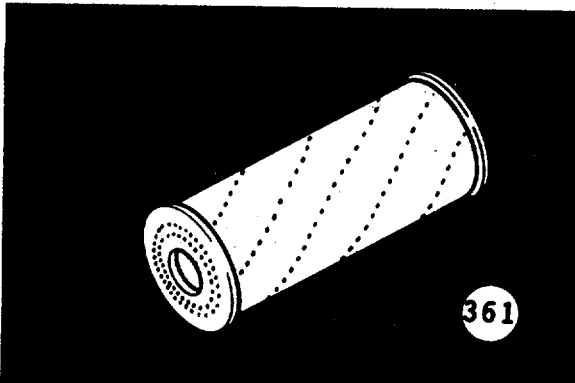
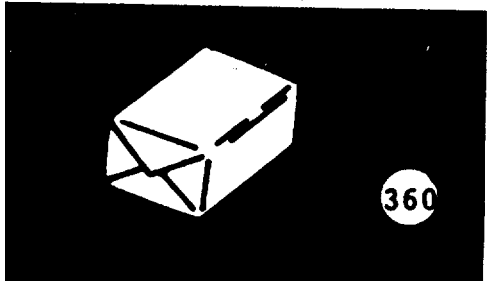
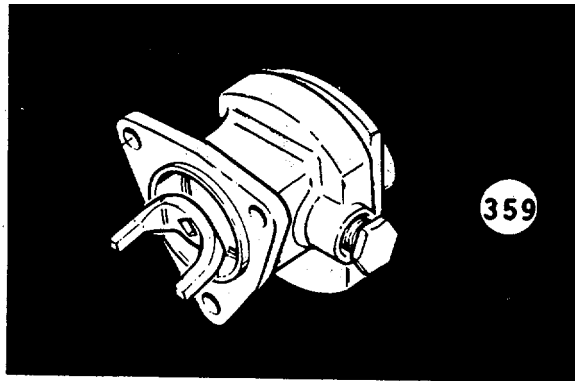
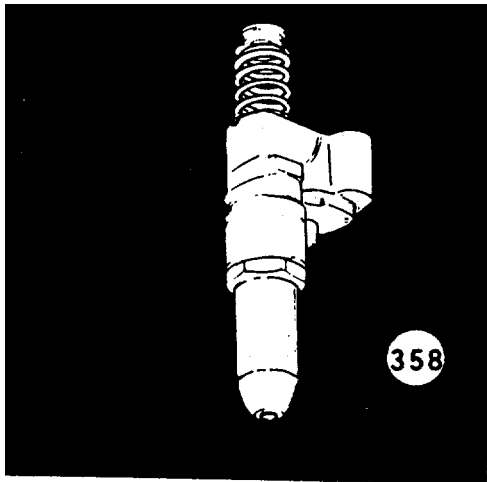

(1) ILLUS NO.	(2) NATIONAL STOCK NUMBER	(3) DESCRIPTION FSCM AND PART NUMBER	(4) USABLE ON CODE U/M	(5) QTY RQR
358	2910-00-911-0139	Injector, Fuel (72582) 5228770	EA	24
359	2910-01-024-9238	Pump, Fuel (72582) 5199735	EA	2
360	2910-00-880-0054	Overhead Kit, Fuel Pump (72582) 5196938	EA	2
361	2910-00-089-6012	Element, Fuel Filter (72582) 6436719	EA	12

SECTION III. BASIC ISSUE ITEMS LIST (CONTINUED).

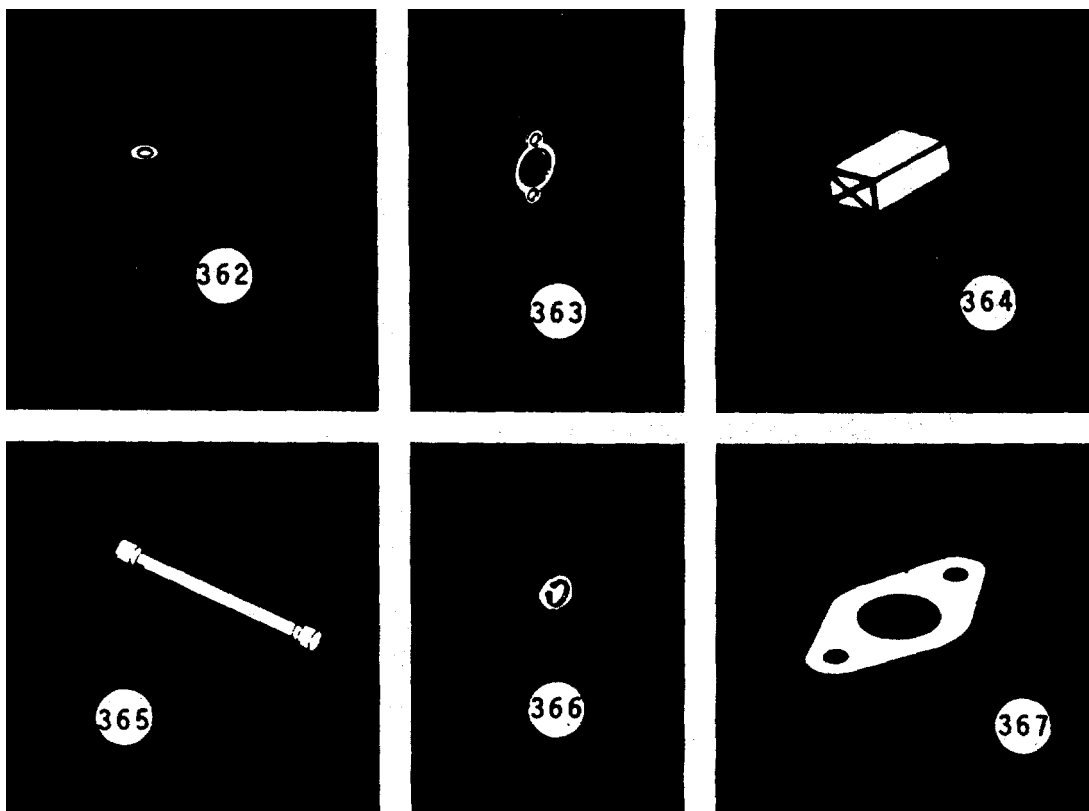

(1) ILLUS NO.	(2) NATIONAL STOCK NUMBER	(3) DESCRIPTION FSCM AND PART NUMBER	(4) USABLE ON CODE U/M	(5) QTY RQR
362	5330-00-930-3244	Gasket, Fuel Filter Cover Screw (72582) 6435794	EA	4
363	5330-00-250-5817	Gasket, Governor High Speed Spring Cover (72582) 5152944	EA	2
364	2815-00-837-8371	Installation Kit, Blower (72582) 5196386	EA	1
365	2990-01-009-8178	Shaft, Blower Drive (72582) 5148253		EA
1 366	5365-00-266-1963	Ring, Snap, Blower Drive Shaft (Ind) (72582) 5154637	EA	1
367	5330-00-735-4291	Gasket, Pressure Regulator (72582) 5117269	EA	1

SECTION III. BASIC ISSUE ITEMS LIST (CONTINUED).

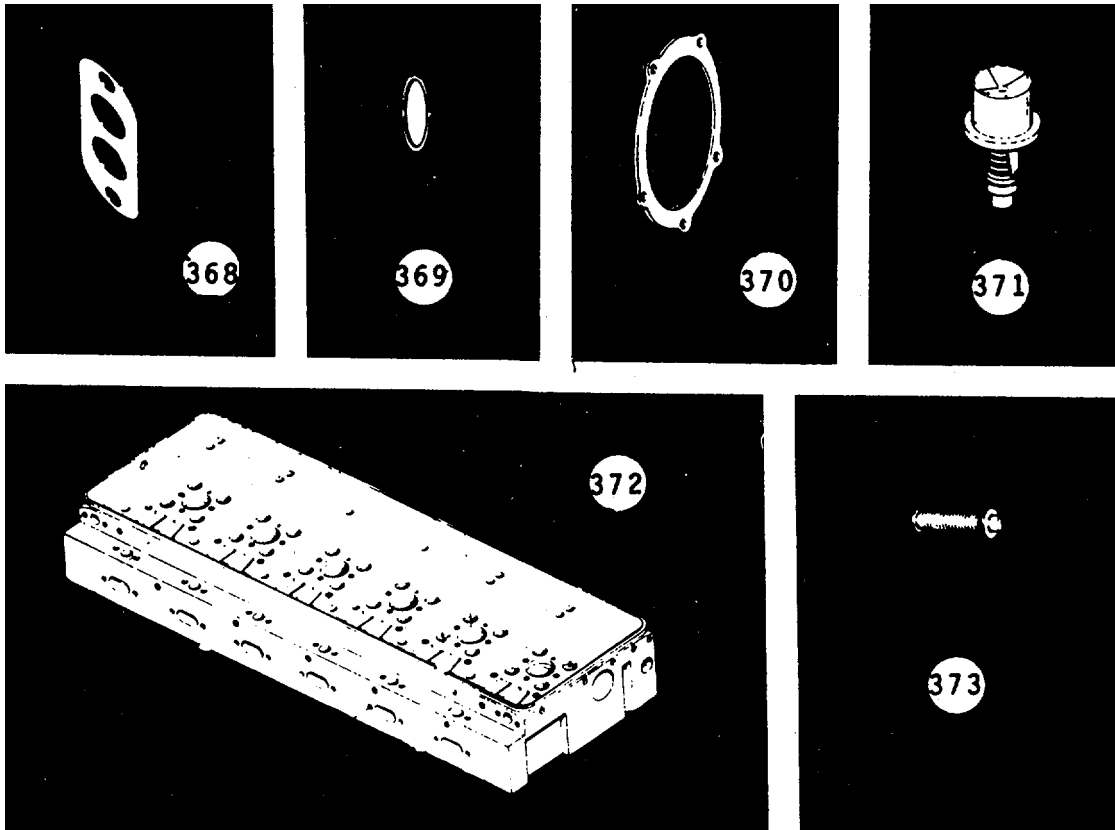

(1) ILLUS NO.	(2) NATIONAL STOCK NUMBER	(3) DESCRIPTION FSCM AND PART NUMBER	(4) USABLE ON CODE U/M	(5) QTY RQR
368	5330-00-835-6131	Gasket, (FF) Filter Cover Screw (72582) 5117575	EA	4
369	5330-00-736-3508	Gasket, (FF) Filter By-Pass Valve (72582) 5575086	EA	1
370	5330-00-758-2868	Gasket, (FW) Pump cover (72582) 5117976	EA	1
371	6620-00-846-9848	Thermostat Assembly (72582) 5119826	EA	2
372	2815-01-012-5834	Head, Cylinder Complete (72582) 5199717	EA	2
373	4720-01-071-2848	Hose, Metal, Flexible 205-4661556-23	EA	4

SECTION III. BASIC ISSUE ITEMS LIST (CONTINUED).

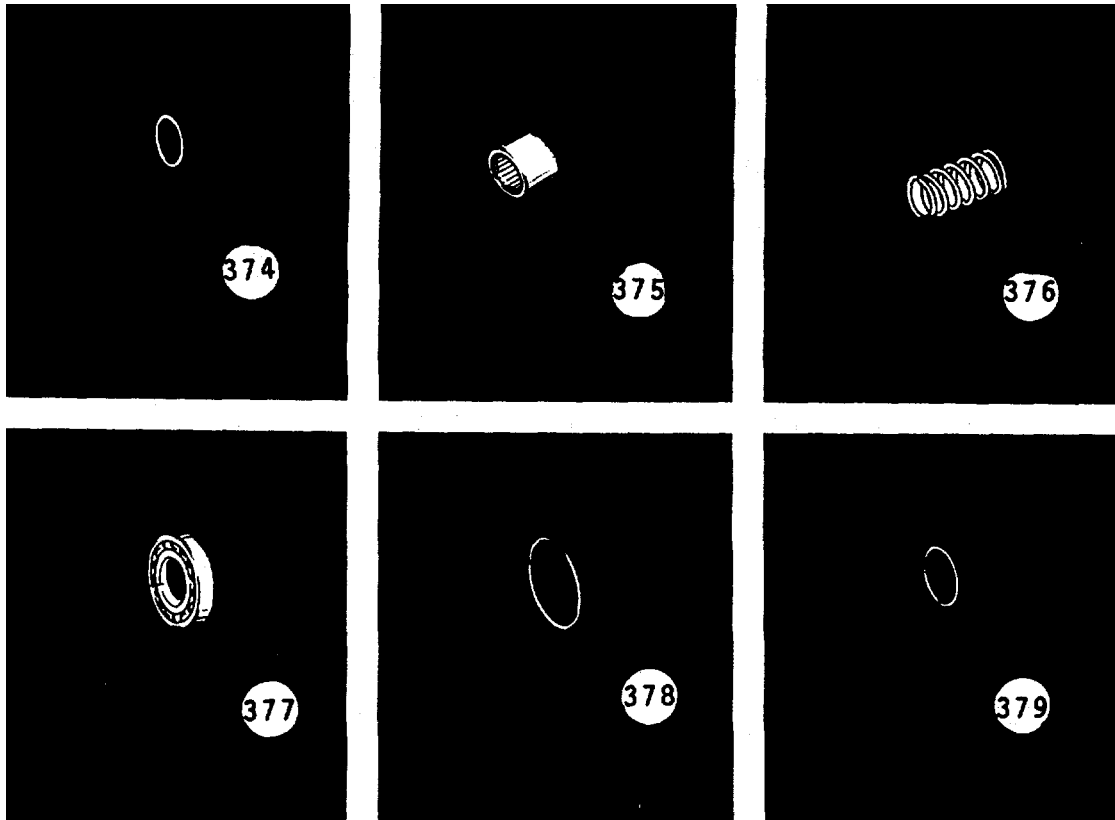

(1) ILLUS NO.	(2) NATIONAL STOCK NUMBER	(3) DESCRIPTION FSCM AND PART NUMBER	(4) USABLE ON CODE U/M	(5) QTY RQR
		The following 11 items are u/o American Bosch Engine Hydraulic Cranking System		
374	5330-00-052-1853	"O" Ring (01843) GA1129-2	EA	4
375	3120-00-227-3237	Bearing Roller (01843) BN1013	EA	2
376	2990-00-646-6439	Spring, Barrel (01843) SP 202663	EA	2
377	3110-00-554-5611	Bearing, Ball	EA	2
378	5330-00-897-2626	"O" Ring, Outer Seal (01843) GS 100064	EA	2
379	5330-00-897-2625	"O" Ring, Inner Seal (01843) GA 100061	EA	2

SECTION III. BASIC ISSUE ITEMS LIST (CONTINUED).

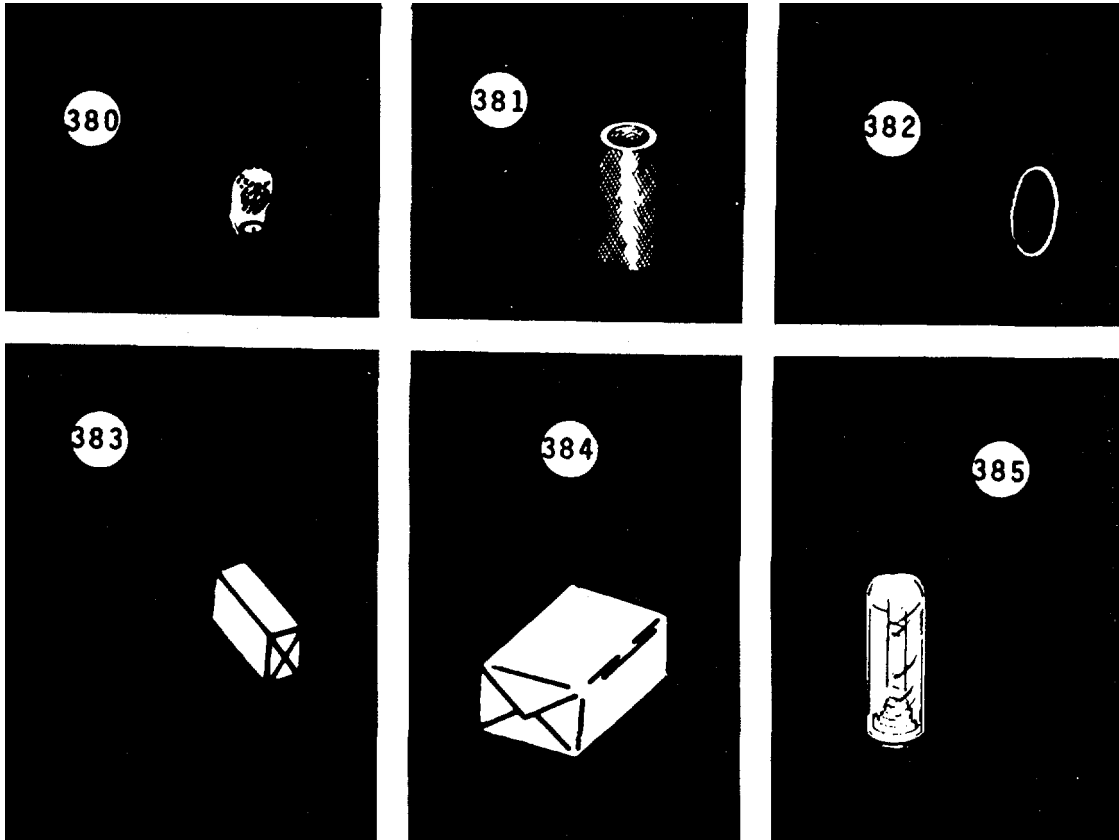

(1) ILLUS NO.	(2) NATIONAL STOCK NUMBER	(3) DESCRIPTION FSCM AND PART NUMBER	USABLE ON CODE	(4) U/M	(5) QTY RQR
380	5340-00-740-1274	Fuse Assembly (01843) FU 20257203		EA	5
381	2940-00-810-5686	Element, Filter (01843) FE 200575		EA	6
382	5330-00-897-2641	"O" Ring (01843) GA 100201		EA	6
383	2990-00-824-0454	Kit, Repair (01843) KT 202777		EA	3
384	2910-00-839-6239	Kit, Repair (01843) KT 202565		EA	3
		The following 4 items are u/o Carlisle and Finch 12 inch Signaling Searchlight			
385	6240-00-143-3142	Lamp, 1000W (96906) MS25015		EA	2

SECTION III. BASIC ISSUE ITEMS LIST (CONTINUED).

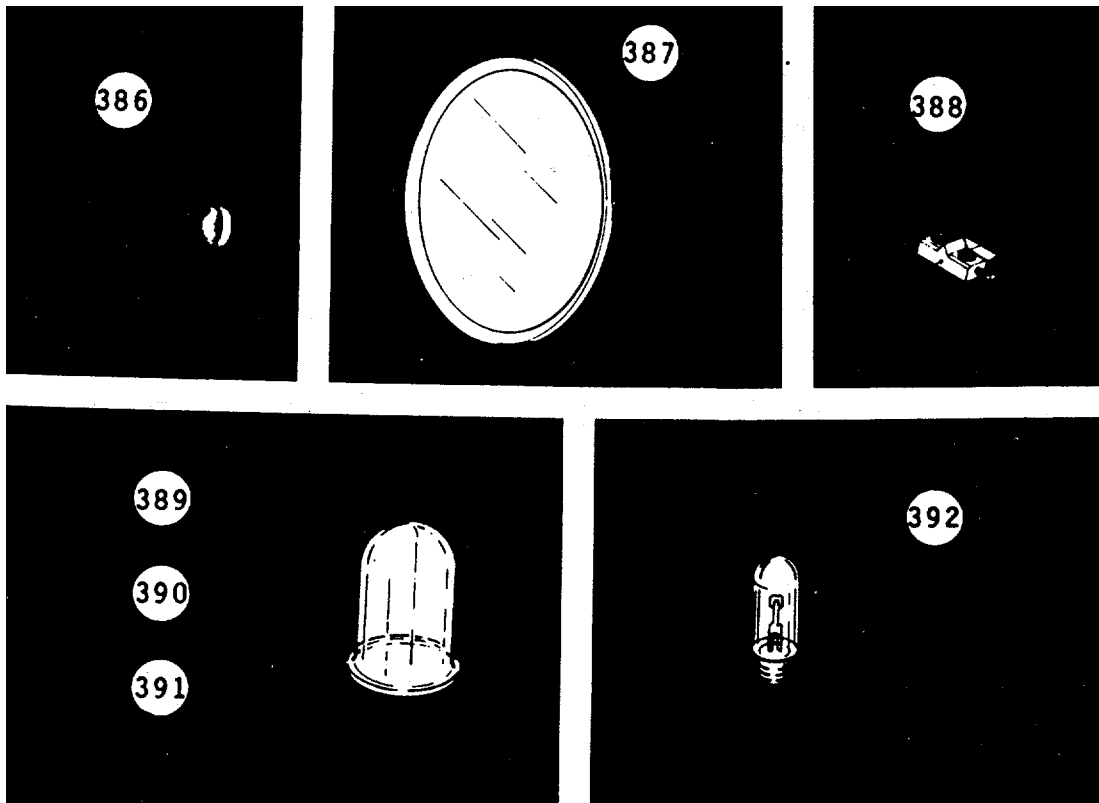

(1) ILLUS NO.	(2) NATIONAL STOCK NUMBER	(3) DESCRIPTION FSCM AND PART NUMBER	USABLE ON CODE	(4) U/M	(5) QTY RQR
386	5360-00-619-3418	Spring, Shutter (10741) SP16-1		EA	1
387	6230-00-299-5902	Glass, Cover (10741) FE15F		EA	1
388	6250-00-785-6482	Lamp holder (10741) FE 132X		EA	1
		The following 4 items are u/o Carlisle and Finch Navigation Lights			
389	6220-00-722-4496	Globe, Clear (96906) MS16867-1		EA	1
390	6220-00-715-2029	Globe, Green (96906) MS168623-3		EA	1
391	6220-00-722-2013	Globe, Red (96906) MS16867-2		EA	1
392	6240-00-577-8455	Lamp, 115V		EA	12

SECTION III. BASIC ISSUE ITEMS LIST (CONTINUED).

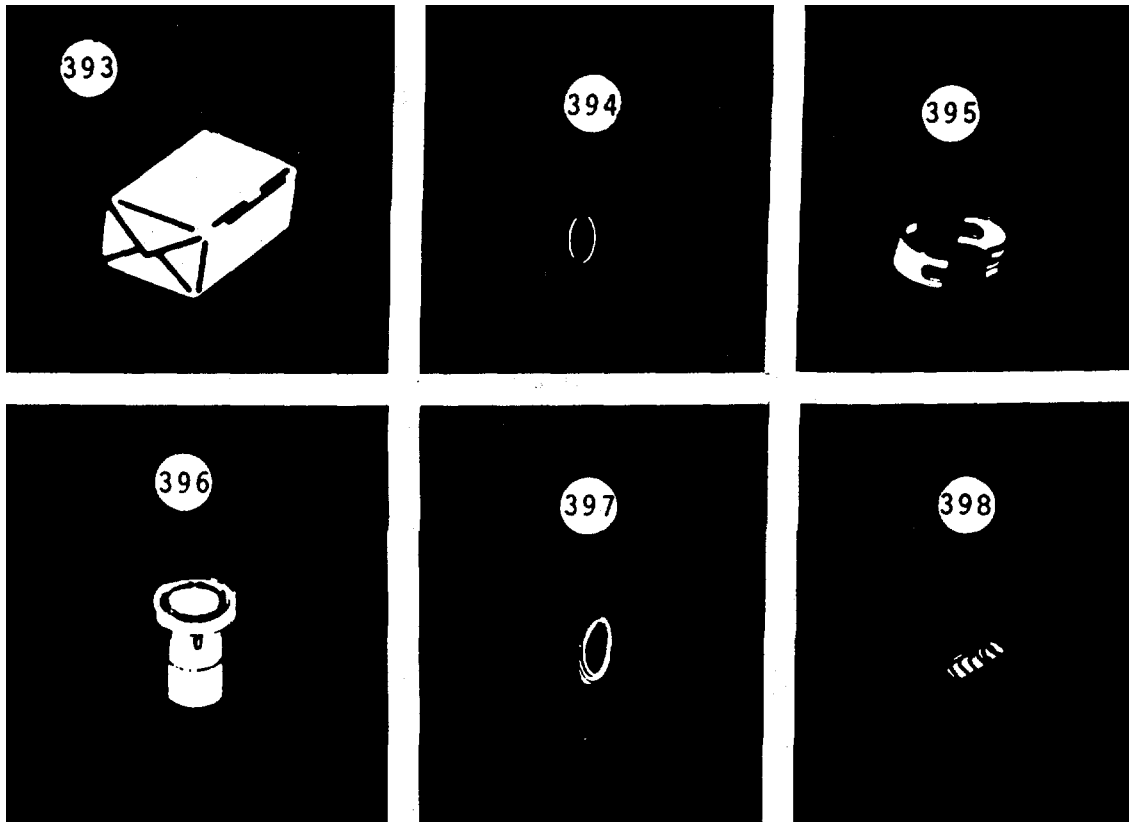

(1) ILLUS NO.	(2) NATIONAL STOCK NUMBER	(3) DESCRIPTION FSCM AND PART NUMBER	(4) USABLE ON CODE U/M	(5) QTY RQR
393	5330-01-040-7867	The following 23 items are u/o Carrier-Transicold Air Conditioning Plant, Gasket Set (10855) 5F20660001	EA	1
394	4130-00-625-4955	Seal, Shaft (10855) 5F20-676	EA	1
395	3120-00-796-2600	Bearing Pkg, Con Rod (10855) 5F20-451	EA	3
396	4130-00-895-1693	Spring Discharge Valve (10855) 6G45-1151	EA	12
397	4130-00-393-4901	Disc, Suction Valve (10855) SF20-1142	EA	3
398	5360-00-200-4445	Spring Suction (10855) 5F20-1791	EA	18

SECTION III. BASIC ISSUE ITEMS LIST (CONTINUED).

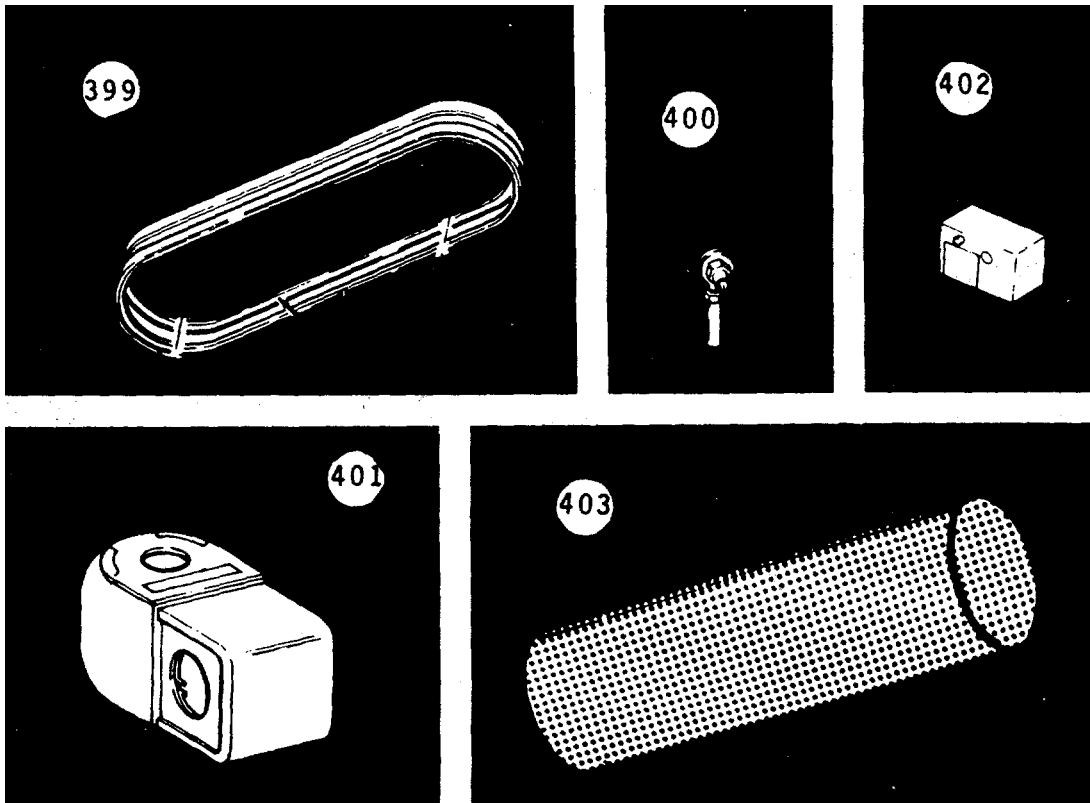

(1) ILLUS NO.	(2) NATIONAL STOCK NUMBER	(3) DESCRIPTION FSCM AND PART NUMBER	USABLE ON CODE	(4) U/M	(5) QTY RQR
399	3030-01-040-8904	"V" Belt Pkg (10855) 5F20-A201		EA	1
400	4820-00-287-4045	Valve, Relief (28193) 5422		EA	2
401	5950-01-034-7163	Coil, Liquid Solenoid Valve (20418) AMG-12OV60HZ		EA	2
402	5930-00-152-8112	Switch Oil (10855) 5F20-212		EA	1
403	4440-00-494-9427	Cartridge, Drier (28193) 73-C-M		EA	1

SECTION III. BASIC ISSUE ITEMS LIST (CONTINUED).

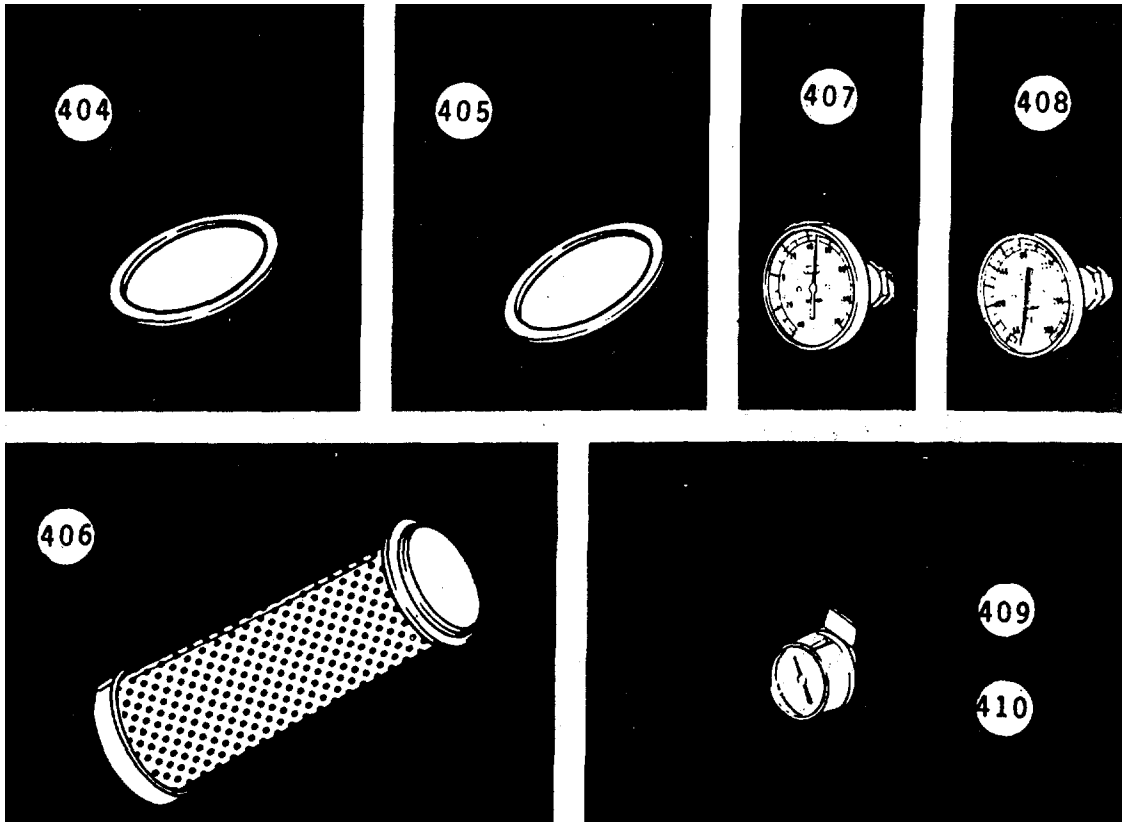

(1) ILLUS NO.	(2) NATIONAL STOCK NUMBER	(3) DESCRIPTION FSCM AND PART NUMBER	(4) U/M	(5) QTY RQR
404	5330-00-297-7369	Gasket, Flange, Drier (28193) U-203-4	EA	1
405	5330-00-297-6119	Gasket, Strainer (28193) U-201-4	EA	1
406	4730-00-202-8880	Cartridge, Strainer (10855) U-201-5A	EA	1
407	6685-01-044-0244	Thermometer, 3 inches-40°F 12°F (64467) 3A04	EA	2
408	6685-01-044-0245	Thermometer, 3 inches-50°F 300°F (64467) 3A04	EA	1
409	6685-01-044-0236	Gauge, Pressure (64467) BQ13-PFNS-RWXX	EA	1
410	6685-01-044-0237	Gauge, Pressure (64467) BQ13-POOS-RWXX	EA	1

SECTION III. BASIC ISSUE ITEMS LIST (CONTINUED).

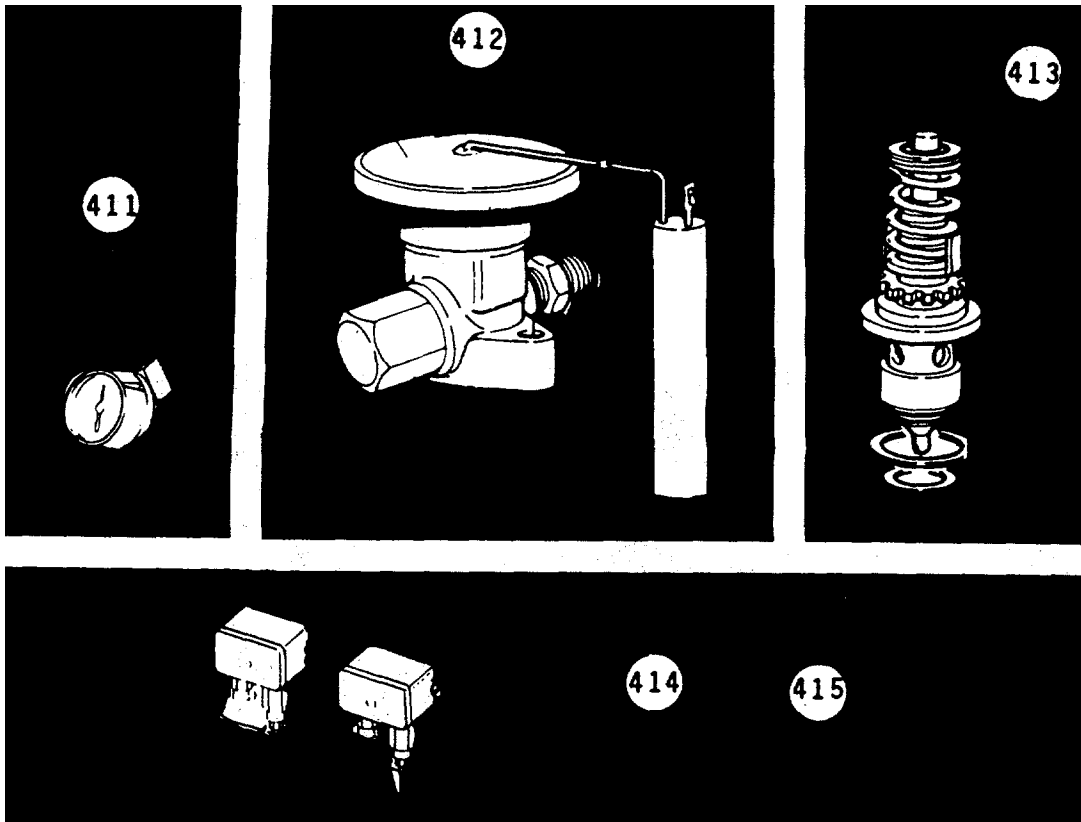

(1) ILLUS NO.	(2) NATIONAL STOCK NUMBER	(3) DESCRIPTION FSCM AND PART NUMBER	(4) USABLE ON CODE U/M	(5) QTY RQR
411	6685-01-044-0238	Gauge, Pressure (64467) BA13-PPFS-RWXX	EA	1
412	4820-01-041-9947	Power Assy, Thermal Expansion Valve (19278) XB1019FW552B	EA	1
413	4820-00-036-3755	Cage Assy, Thermal Expansion Valve (20418) XC724-B4B	EA	1
414		Switch, High Pressure (19278) 223876CB7	EA	1
415	5930-01-050-0535	Switch, Low Pressure (19278) 223875CB3	EA	2

SECTION III. BASIC ISSUE ITEMS LIST (CONTINUED).

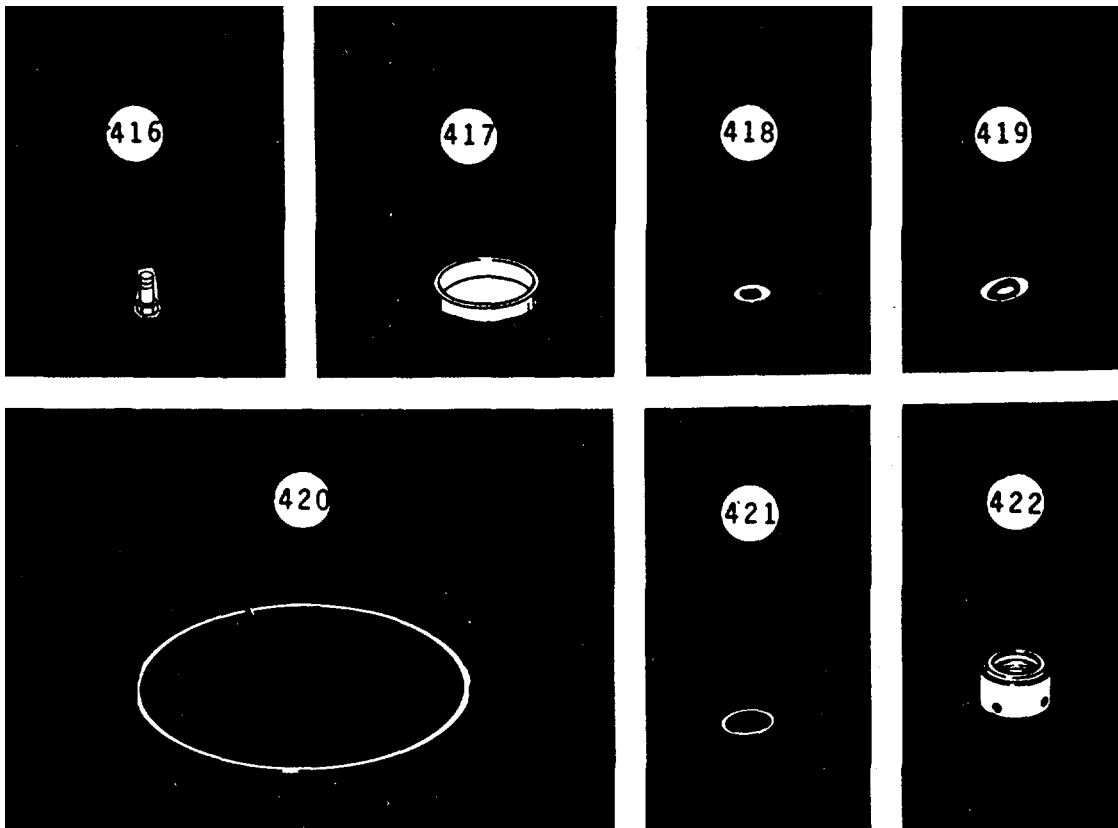

(1) ILLUS NO.	(2) NATIONAL STOCK NUMBER	(3) DESCRIPTION FSCM AND PART NUMBER USABLE ON CODE	(4) U/M	(5) QTY RQR
		The following 7 items are u/o Crane Deming Fire Pump		
416	5305-01-041-1654	Screw, Impeller (16859) 0053313	EA	1
417	4320-01-070-0545	Ring, Wear, Packing Box (16859) 8068181	EA	1
418	5330-01-040-3922	Gasket, Impeller Washer (16859) 0068363	EA	1
419	5330-01-040-3923	Gasket, Shaft (16859) 0068367	EA	1
420	5330-01-040-6652	Gasket, Casing (16859) 0057164	EA	1
421	5330-01-040-3912	"O" Ring, Impeller Screw (16859) 0068365	EA	1
422		Seal, Single, Mech, T Type (16859) 0072271	EA	1

SECTION III. BASIC ISSUE ITEMS LIST (CONTINUED).

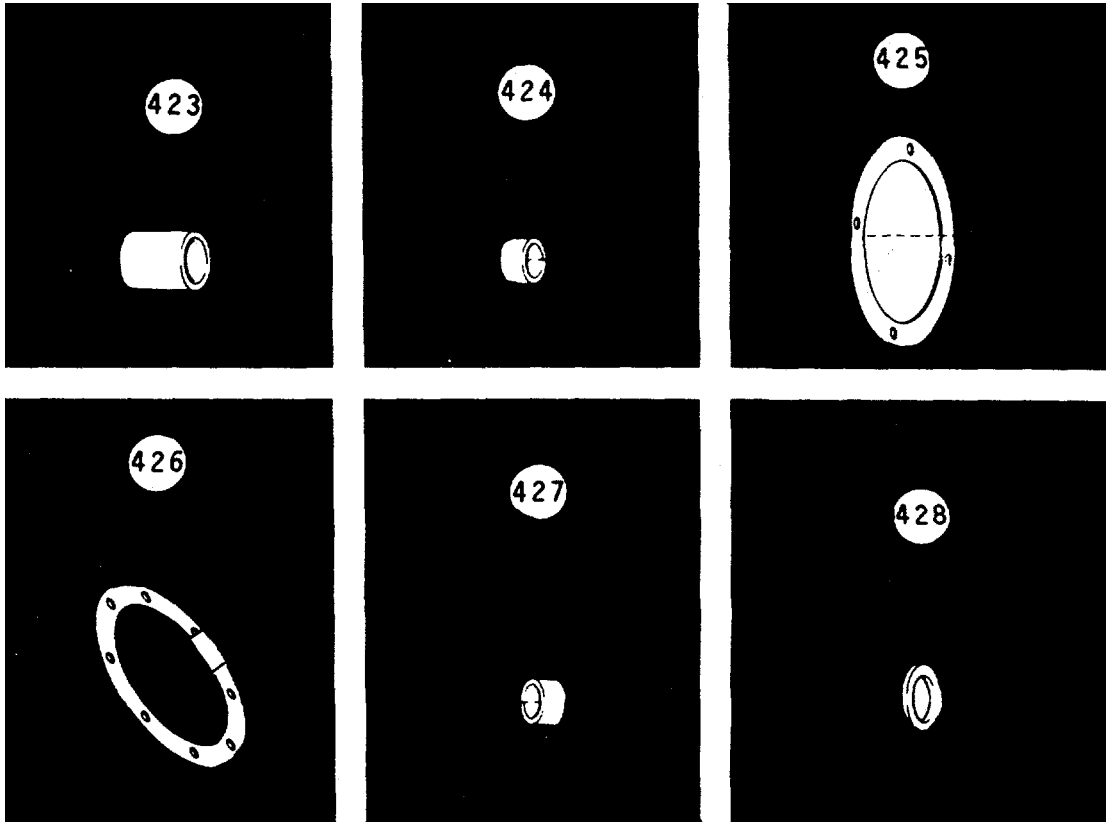

(1) ILLUS NO.	(2) NATIONAL STOCK NUMBER	(3) DESCRIPTION FSCM AND PART NUMBER	(4) USABLE ON CODE U/M	(5) QTY RQR
		The following 6 items are u/o Crane/Deming Standby Lube Oil Pump.		
423	3120-01-041-1638	Bushing, Graphite Back Head (#35) (16859) 0029178	EA	1
424	3120-01-041-1639	Bushing, Idler, Graphite (#98) (16859)	EA	1
425	5330-01-040-3921	Gasket, Head (#159) (16859) 0046888	EA	1
426	5330-01-040-3924	Gasket, Back Head (#161) (16859) 0049631	EA	1
427	5315-01-073-8962	Pin, Idler (#252) (16859) 0046899	EA	1
428	5330-01-040-3846	Seal (#451) (16859) 0029177	EA	1

SECTION III. BASIC ISSUE ITEMS LIST (CONTINUED).

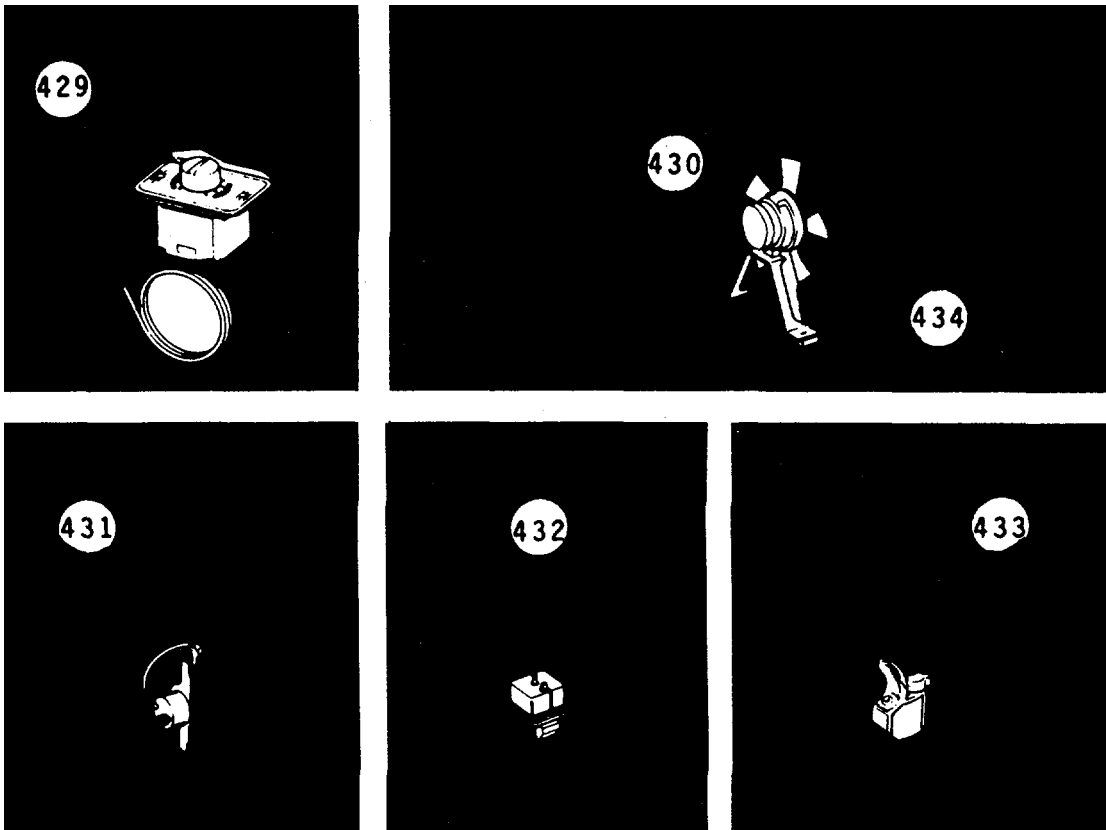

(1) ILLUS NO.	(2) NATIONAL STOCK NUMBER	(3) DESCRIPTION FSCM AND PART NUMBER	(4) U/M	(5) QTY RQR
		The following 6 items are u/o EBCO Drinking Fountain		
429	4510-00-928-2473	Control, Cold (19177) 17352	EA	1
430	4140-01-044-7993	Blade, Fan (19177) 17820	EA	1
431	5925-01-047-6301	Overload (19177) 17977	EA	1
432	5945-01-047-5264	Relay (19177) 18461	EA	1
433	4510-01-079-8535	Valve, Bubbler (19177) 011490	EA	1
434	6105-01-124-5829	Motor, Fan w/Bracket Assy (19177) 16490	EA	1

SECTION III. BASIC ISSUE ITEMS LIST (CONTINUED).

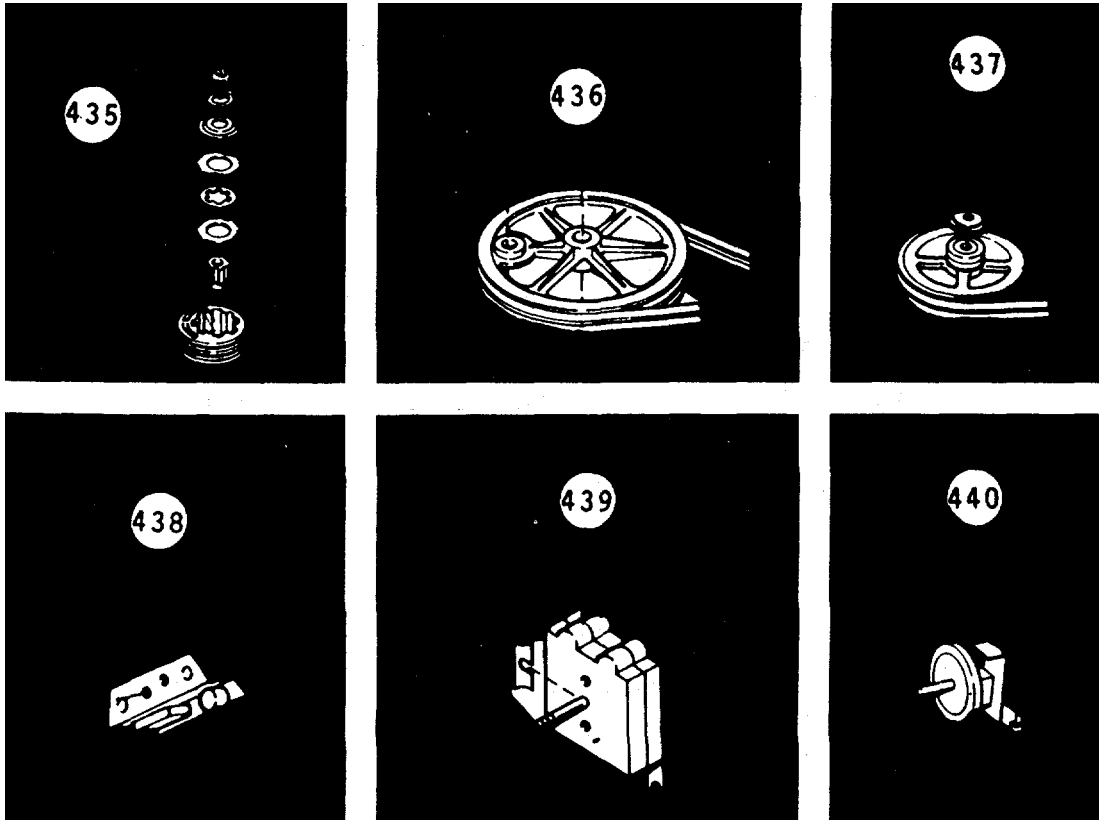

(1) ILLUS NO.	(2) NATIONAL STOCK NUMBER	(3) DESCRIPTION FSCM AND PART NUMBER	(4) USABLE ON CODE U/M	(5) QTY RQR
		The following 14 items are u/o Frigidaire Washer/Dryer		
435	3510-01-043-8550	Clutch (23671) 635147	EA	1
436	3030-01-042-0255	Belt Set (23671) 634913	EA	4
437	3030-01-037-4934	Belt Set (23671) 634914	EA	4
438	6645-01-068-3042	Timer, Washer (23671) 636442	EA	1
439	5930-01-043-4390	Switch, Water Temp (23671) 633640	EA	1
440	3510-01-019-0591	Water Level (23671) 634964	EA	1

SECTION III. BASIC ISSUE ITEMS LIST (CONTINUED).

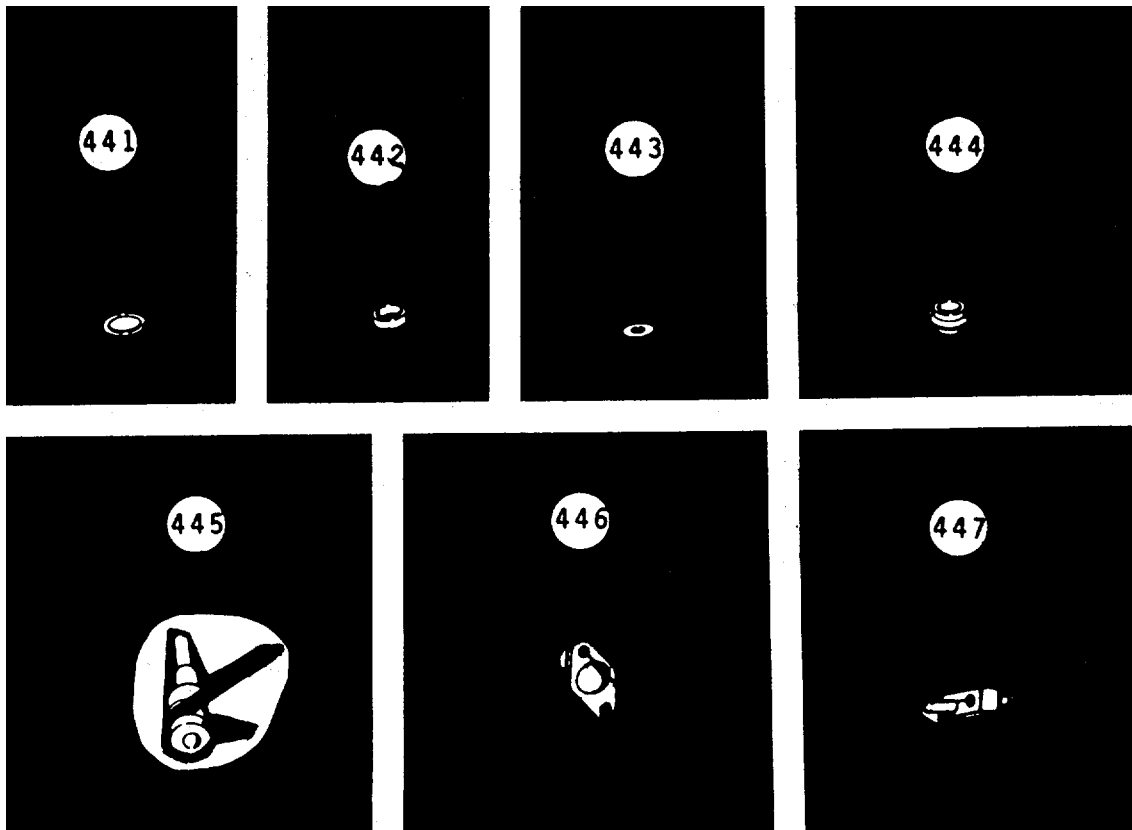

(1) ILLUS NO.	(2) NATIONAL STOCK NUMBER	(3) DESCRIPTION FSCM AND PART NUMBER	USABLE ON CODE	(4) U/M	(5) QTY RQR
441	5330-01-040-3919	Gasket (23671) 1126048		EA	1
442	5330-01-020-5716	Gasket (23671) 6598955		EA	1
443	5330-01-020-5717	Seal (23671) 1126013		EA	1
444	5330-01-020-5715	Seal (23671) 6599277		EA	1
445	3030-01-037-4934	Belt (23671) 639357		EA	1
446	5920-01-037-5869	Thermostat (23671) 633927		EA	4
447	5930-01-043-5894	Selector, Dryer		EA	1

SECTION III. BASIC ISSUE ITEMS LIST (CONTINUED).

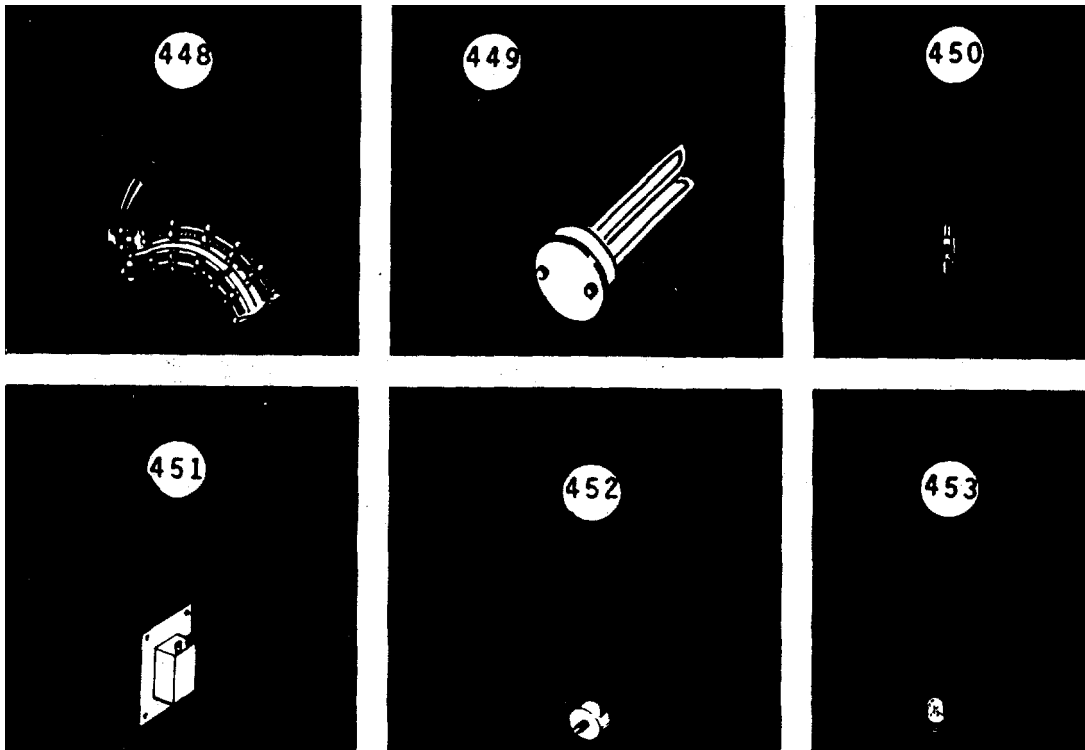

(1) ILLUS NO.	(2) NATIONAL STOCK NUMBER	(3) DESCRIPTION FSCM AND PART NUMBER	(4) USABLE ON CODE U/M	(5) QTY RQR
448	3510-01-019-0592	Element, 3000W, 240V (23671) 633897 The following 1 item is u/o E.L. Wiegand Division of Emerson Electric - Circulation Water Heater	EA	1
449	4540-00-938-2907	Element, Heating (19857) 3-38682 The following 4 items are u/o Wing Corp. Alarm Switchboard.	EA	1
450	5905-00-454-2818	Resistor, Fixed 0.75 Megohms, 2W RCR 32GTE4JS	EA	1
451	5945-00-925-4360	Relay (77342) SPIA120V	EA	1
452	5930-00-222-5984	Switch, Rotary (71590) PA600-397	EA	1
453	6240-00-179-1814	Lamp, Neon (96906) MS15098-5-002	EA	2

SECTION III. BASIC ISSUE ITEMS LIST (CONTINUED).

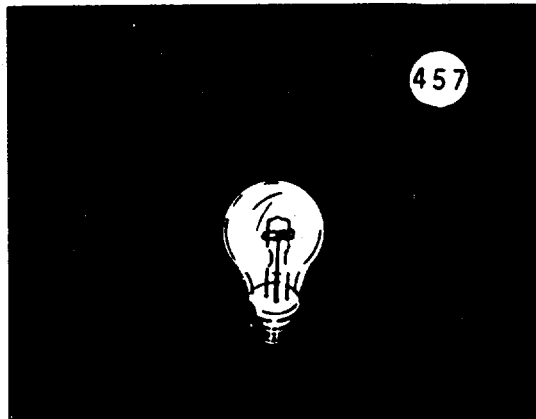
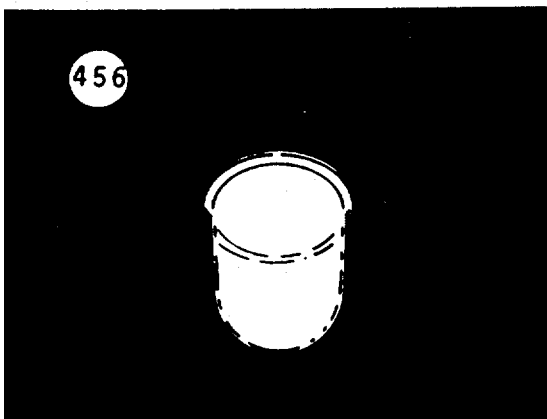
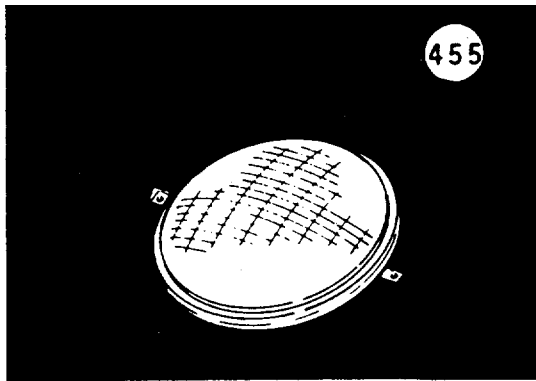
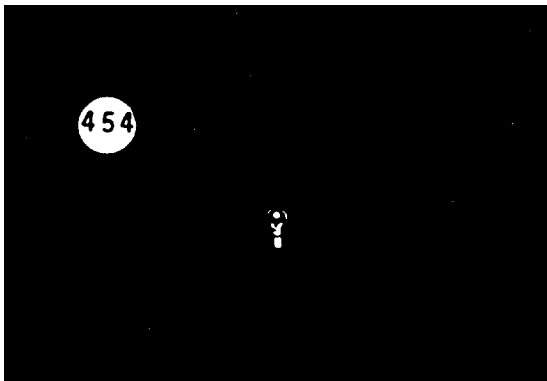

(1) ILLUS NO.	(2) NATIONAL STOCK NUMBER	(3) DESCRIPTION FSCM AND PART NUMBER	(4) USABLE ON CODE U/M	(5) QTY RQR
454	6240-00-939-7859	The following 1 item is u/o Sperry Marine Systems Ship's Course Indicator Lamp, Incandescent (58854) 120MB	EA	2
455	6240-00-056-0737	The following 1 item is u/o Floodlight Symbol 300.2 Lamp (96906) MS15535-6	EA	2
456	6220-00-722-4496	The following 2 items are u/o Anchor Light, Symbol 161.3 Globe (96906) MS16867-1	EA	2
457	6240-00-155-8634	Lamp (96906) MS15586-1	EA	1

SECTION III. BASIC ISSUE ITEMS LIST (CONTINUED).

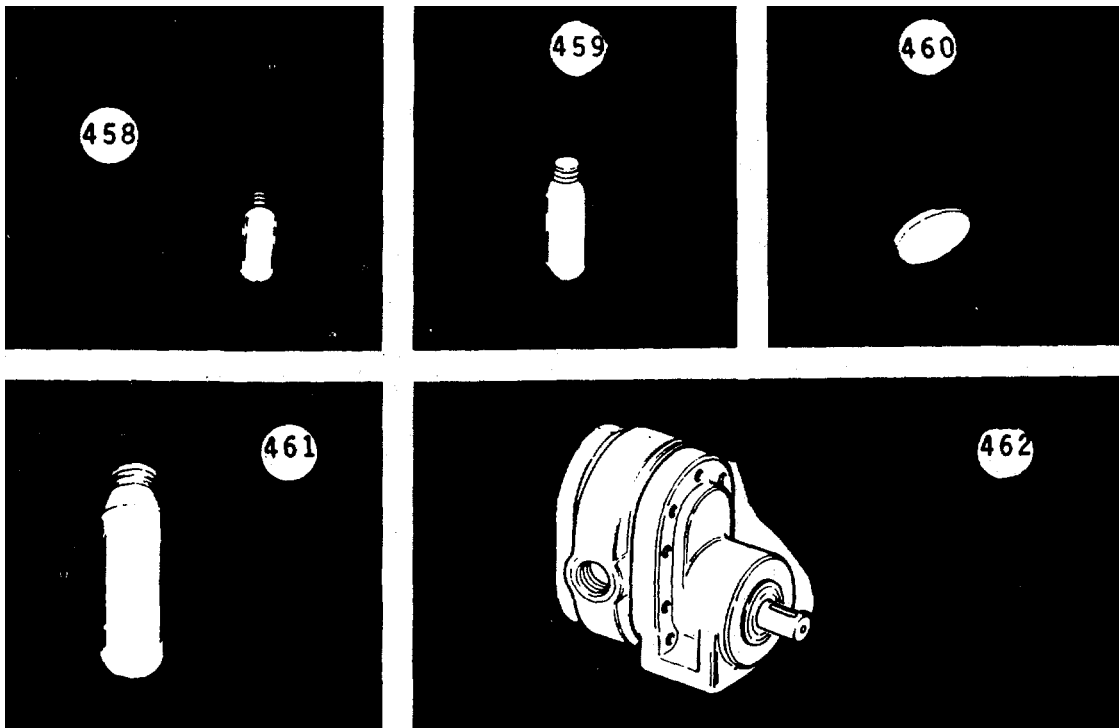

(1) ILLUS NO.	(2) NATIONAL STOCK NUMBER	(3) DESCRIPTION FSCM AND PART NUMBER	(4) USABLE ON CODE U/M	(5) QTY RQR
458	6240-00-617-1719	The following 1 item is u/o Task Light, Symbol 192.1: Lamp (96906) MS15574-1	EA	2
459	6240-00-243-8331	The following 1 item is u/o Blinker Light, Symbol 191.2 Lamp (24446) 15T7C12OMOD The following 2 items are u/o L. L. Rowe Co. Wake Light, Symbol 200.2:	EA	2
460	6120-00-869-9042	Lens (96906) MS17780-6	EA	1
461	6240-00-577-8455	Lamp (50/50T-12) (96906) MS15545-2	EA	2
462	4320-01-040-4624	The following 6 items are u/o Stern Winch Controls: Pump (13829) PD311BAEQ20-4	EA	1

SECTION III. BASIC ISSUE ITEMS LIST (CONTINUED).

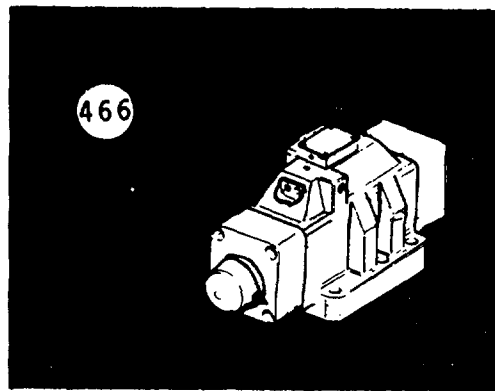
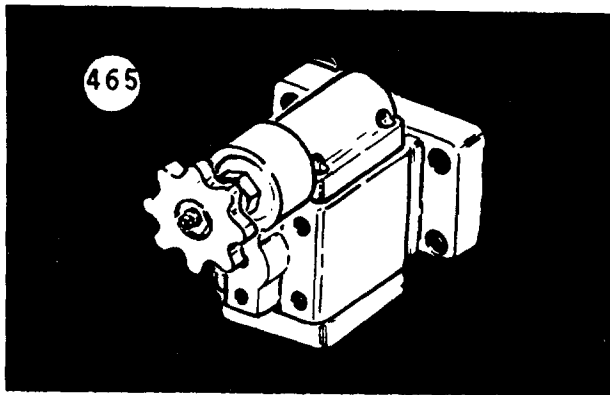
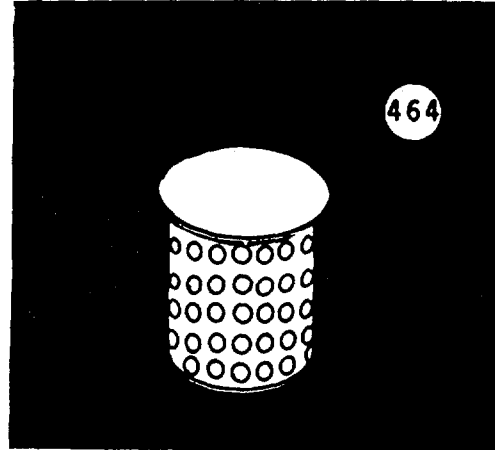
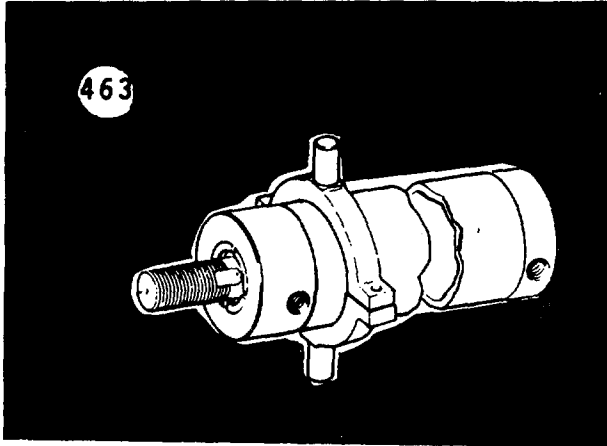

(1) ILLUS NO.	(2) NATIONAL STOCK NUMBER	(3) DESCRIPTION FSCM AND PART NUMBER	(4) USABLE ON CODE U/M	(5) QTY RQR
463	4320-01-049-6450	Cylinder (60285) LSM-5-2	EA	1
464	4330-00-689-3307	Filter, Element (62983) 923117	EA	2
465	4820-00-533-0868	Valve, Pressure Reducing (62983) XGL-03-B-10	EA	1
466		Valve, 4-way (62983) DG3S-4-100A-50	EA	1

SECTION III. BASIC ISSUE ITEMS LIST (CONTINUED).

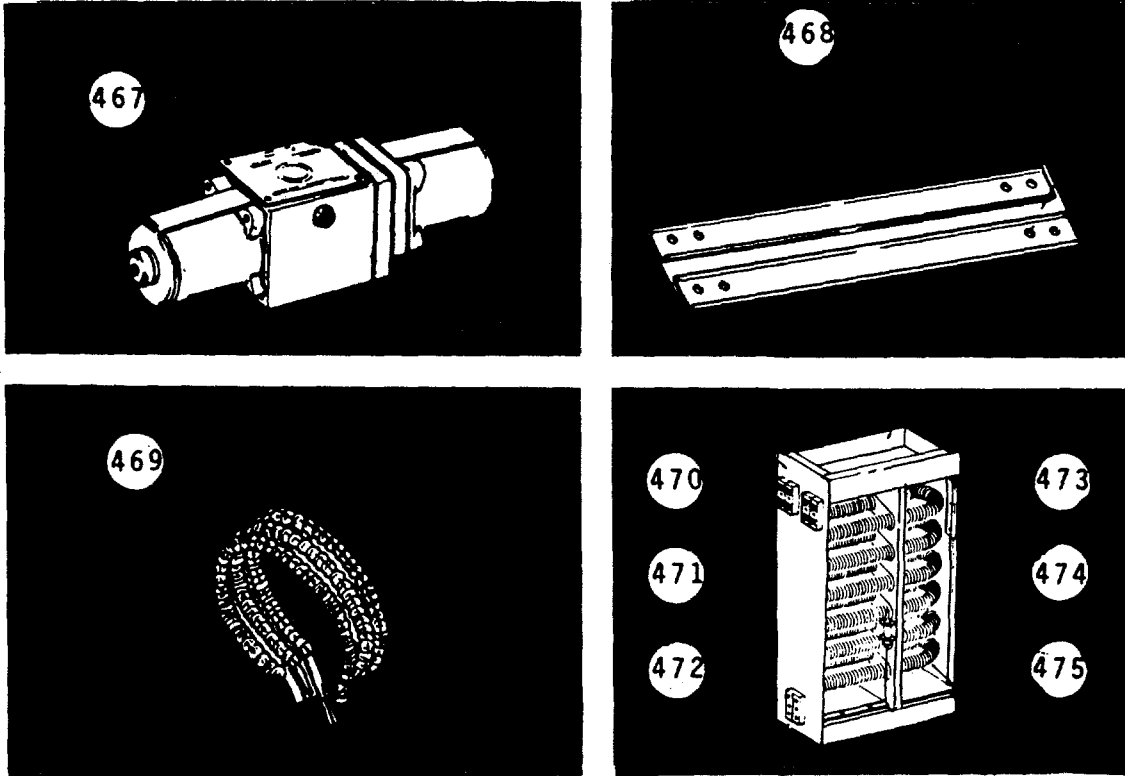

(1) ILLUS NO.	(2) NATIONAL STOCK NUMBER	(3) DESCRIPTION FSCM AND PART NUMBER	(4) U/M	(5) QTY RQR
467	4810-01-070-6823	Valve, 4-way (62983) DG454-016C-50	EA	1
		The following 8 items are u/o Electric Heaters:		
468	4520-01-086-9319	Element, Heating (65586) 003-116586	EA	2
469	4540-01-041-2864	Element, Heating (65586) 118-0452559-004	EA	1
470	4540-01-046-4613	Element, Heating (90176) 1802-7096-091	EA	2
471	4540-01-046-9732	Element, Heating (90176) 1802-7096-001	EA	2
472	4540-01-046-0215	Element, Heating (90176) 1802-7096-222	EA	1
473	4540-01-045-7619	Element, Heating (90176) 1802-7096-016	EA	3
474	4520-01-047-0387	Element, Heating (90176) 1802-7096-027	EA	1
475	4540-01-046-0589	Element, Heating (90176) 1802-7096-135	EA	3

SECTION III. BASIC ISSUE ITEMS LIST (CONTINUED)

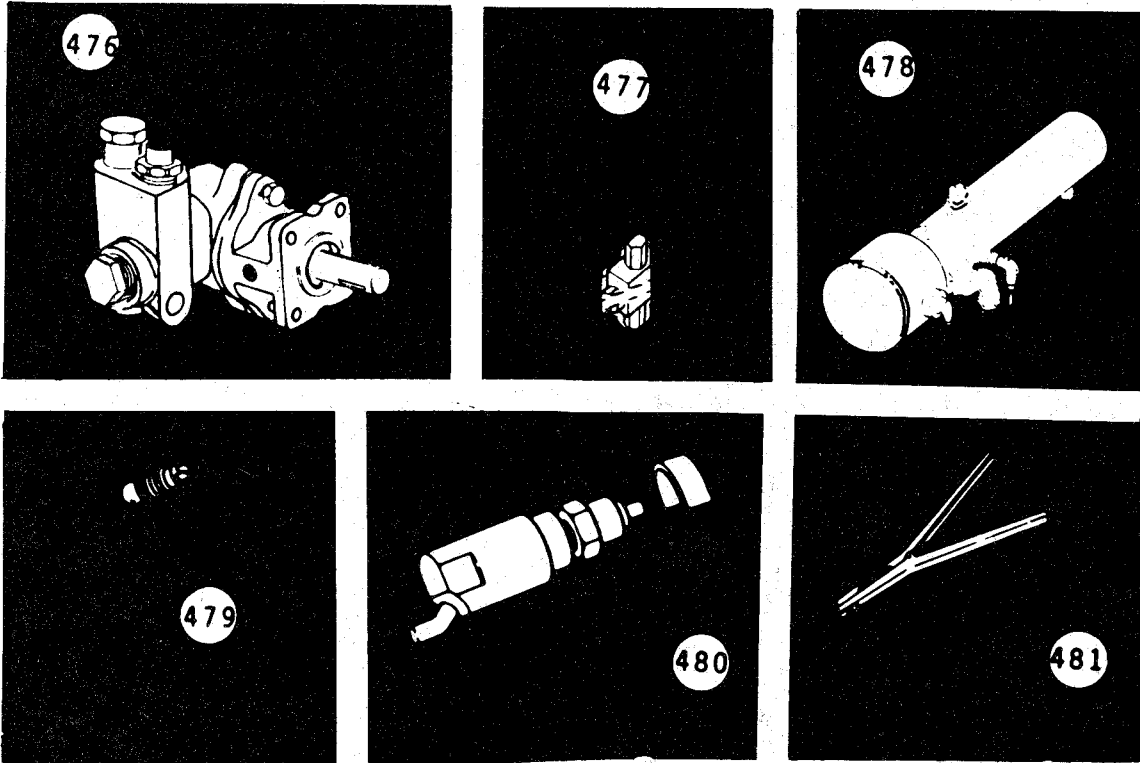

(1) ILLUS NO.	(2) NATIONAL STOCK NUMBER	(3) DESCRIPTION FSCM AND PART NUMBER	(4) USABLE ON CODE U/M	(5) QTY RQR
		The following 1 item is u/o Engine Hydrostarter System:		
476	4320-00-350-8725	Pump, Engine Charging (Hyd) (01843) RPA308090B	EA	1
		The following 1 item is u/o Fluid Controls:		
477	4820-00-875-0823	Valve, Relief 1/4 inch (96259) IDII-F2-60	EA	1
		The following 2 items are u/o Sanitizing Sink Heater by Marionette Marine:		
478	4520-01-070-8574	Element Heating (65586) 054-146335-001	EA	1
479	6240-00-155-7878	Lamp, 6W, 120V (65083) 6S6	EA	3
		<u>SPECIAL TOOLS</u>		
480	5210-00-999-8777	Adapter Compression Gage (33287) J7915-02	EA	1
481	5120-00-494-1846	Assembly Tool, Piston Ring (33287) J8128	EA	1

SECTION III. BASIC ISSUE ITEMS LIST (CONTINUED)

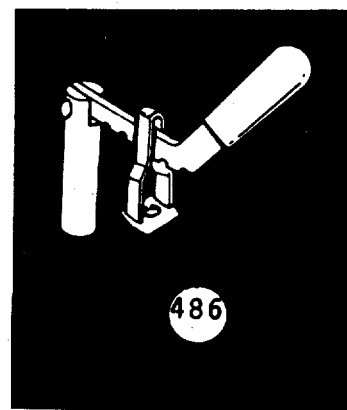
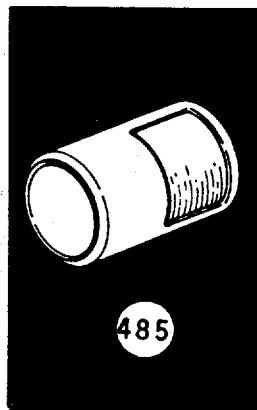
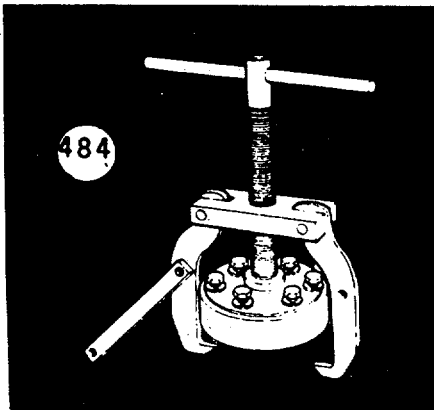
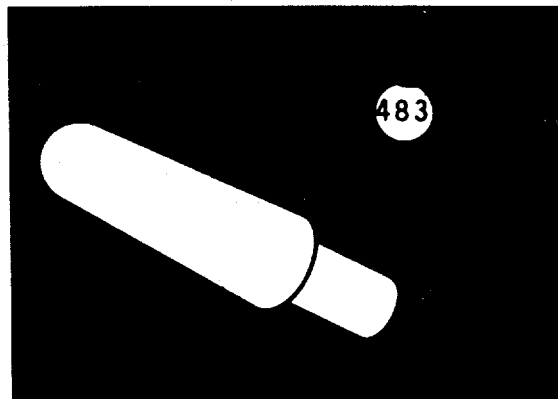
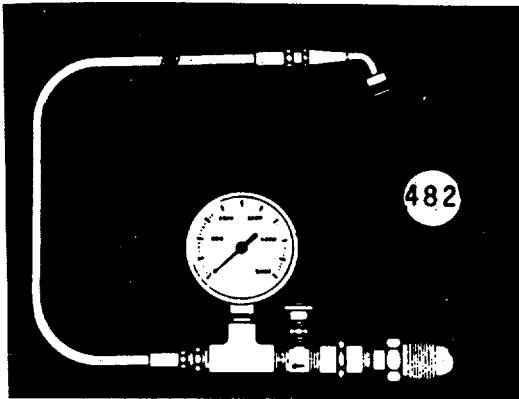

(1) ILLUS NO.	(2) NATIONAL STOCK NUMBER	(3) DESCRIPTION FSCM AND PART NUMBER	(4) USABLE ON CODE U/M	(5) QTY RQR
482	2990-00-897-2535	Assembly, Charging and Gaging (01843) CGA300389	EA	1
483	5120-00-219-8405	Cam Installer, Blower Drive (33287) J1471	EA	1
484	5180-00-136-6120	Clamp Set, Alignment Blower (33287) J23184-01	EA	1
485	5120-00-859-6259	Compressor, Piston Ring (33287) J3272-03	EA	1
486	5120-00-733-8888	Compressor, Valve Spring (33287) J7455	EA	1

SECTION III. BASIC ISSUE ITEMS LIST (CONTINUED)

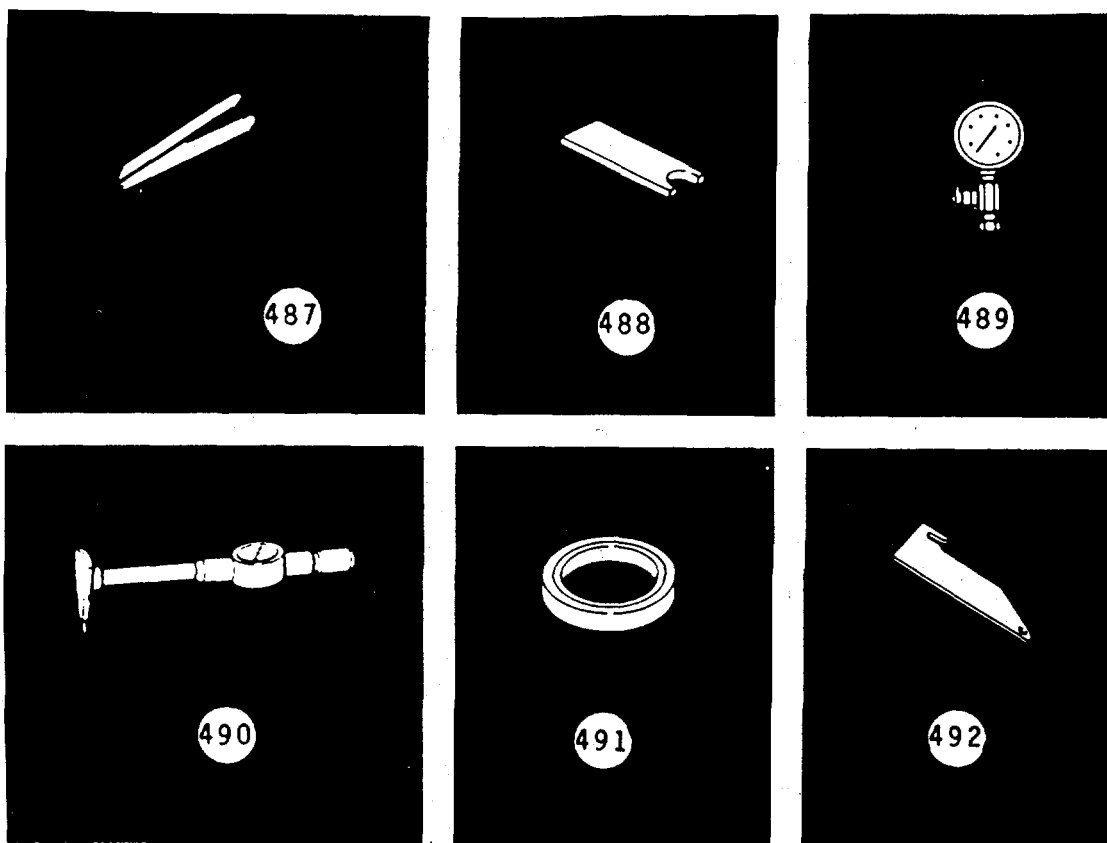

(1) ILLUS NO.	(2) NATIONAL STOCK NUMBER	(3) DESCRIPTION FSCM AND PART NUMBER USABLE ON CODE	(4) U/M	(5) QTY RQR
487	5210-01-048-7085	Gage, Governor Gap (.0015) (33287) J23185	EA	1
488	5210-01-048-6532	Gage, Governor Gap (.200) (33287) J23478	EA	1
489	6620-01-065-3441	Gage, Compression (33287) J4897-5	EA	1
490	5210-01-070-4543	Gage, Cylinder Diameter Checking (33287) J5347-01	EA	1
491	5120-00-937-7631	Gage, Master Ring (33287) J8386-01	EA	1
492	5210-00-125-4415	Gage, Governor Linkage (33287) J21304	EA	1

SECTION III. BASIC ISSUE ITEMS LIST (CONTINUED)

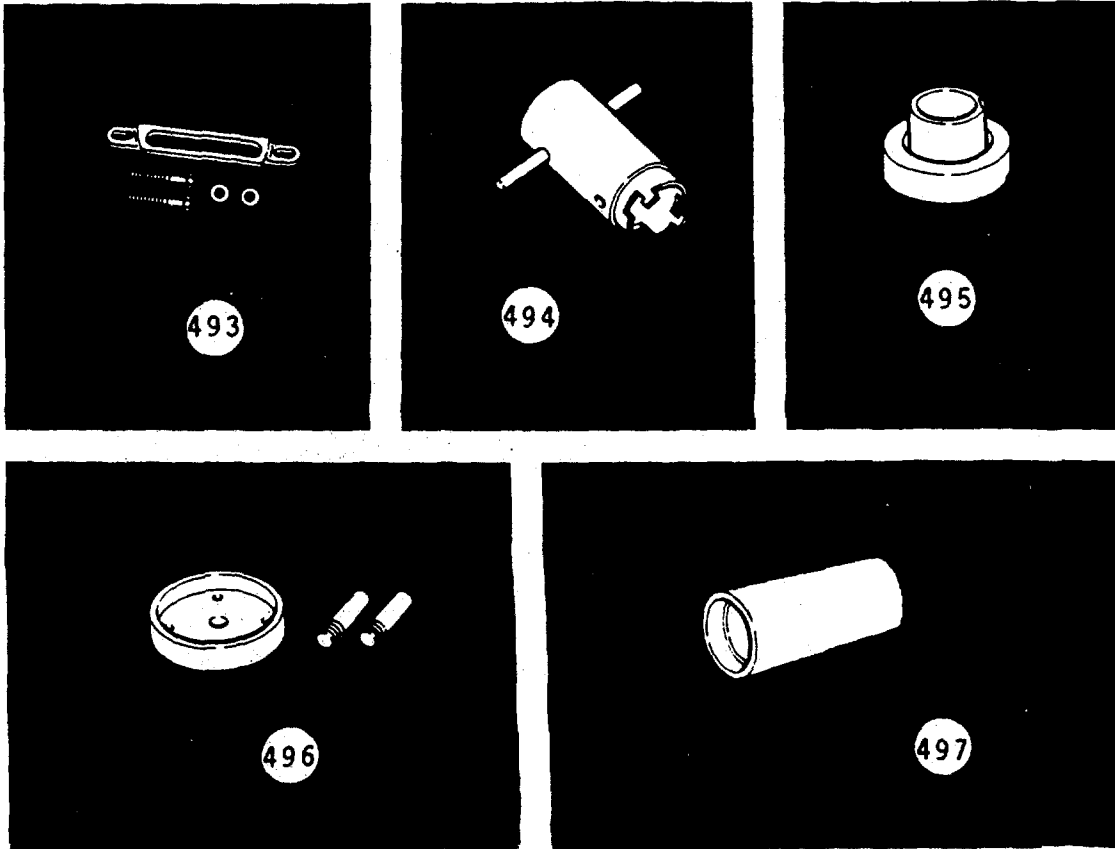

(1) ILLUS NO.	(2) NATIONAL STOCK NUMBER	(3) DESCRIPTION FSCM AND PART NUMBER USABLE ON CODE	(4) U/M	(5) QTY RQR
493	5120-00-999-8618	Holddown Clamp, Cylinder Liner (33287) J21973-01	EA	1
494	5120-01-012-9151	Installer, Water Pump Oil Seal (33287) J22150	EA	1
495	5120-00-937-7267	Installer, Water Pump Seal (33287) J8501	EA	1
496	5120-00-999-8619	Installer, Flywheel Housing Oil Seal (33287) J9727 Installer, Oil Pump Drive Gear (33287) J22825	EA EA	1 1

SECTION III. BASIC ISSUE ITEMS LIST (CONTINUED)

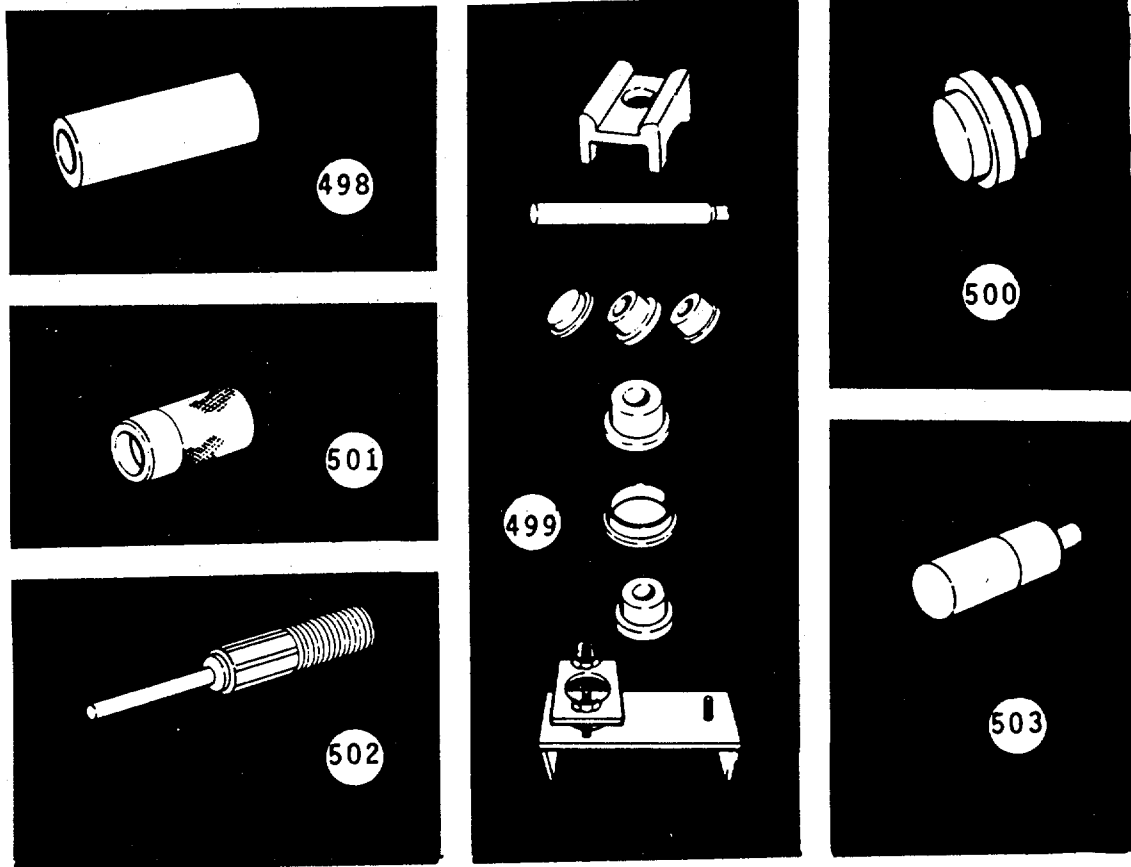

(1) ILLUS NO.	(2) NATIONAL STOCK NUMBER	(3) DESCRIPTION FSCM AND PART NUMBER	(4) USABLE ON CODE U/M	(5) QTY RQR
498	5120-00-937-7268	Installer, Oil Pump Gear (33287) J8509	EA	1
499	5180-00-776-7240	Installer & Remover Set Piston & Connecting Rod Bushing (33287) J1513-01	EA	1
500	5120-00-936-4377	Installer, Crankshaft Oil Seal (33287) J9783	EA	1
501	2815-00-018-2631	Installer, Water Pump Seal (33287) J21971	EA	1
502	5120-00-733-8876	Installer, Valve Seat Insert (33287) J6568	EA	1
503	5120-00-473-7456	Installer, Camshaft Gear (33287) J1903	EA	1

SECTION III. BASIC ISSUE ITEMS LIST (CONTINUED)

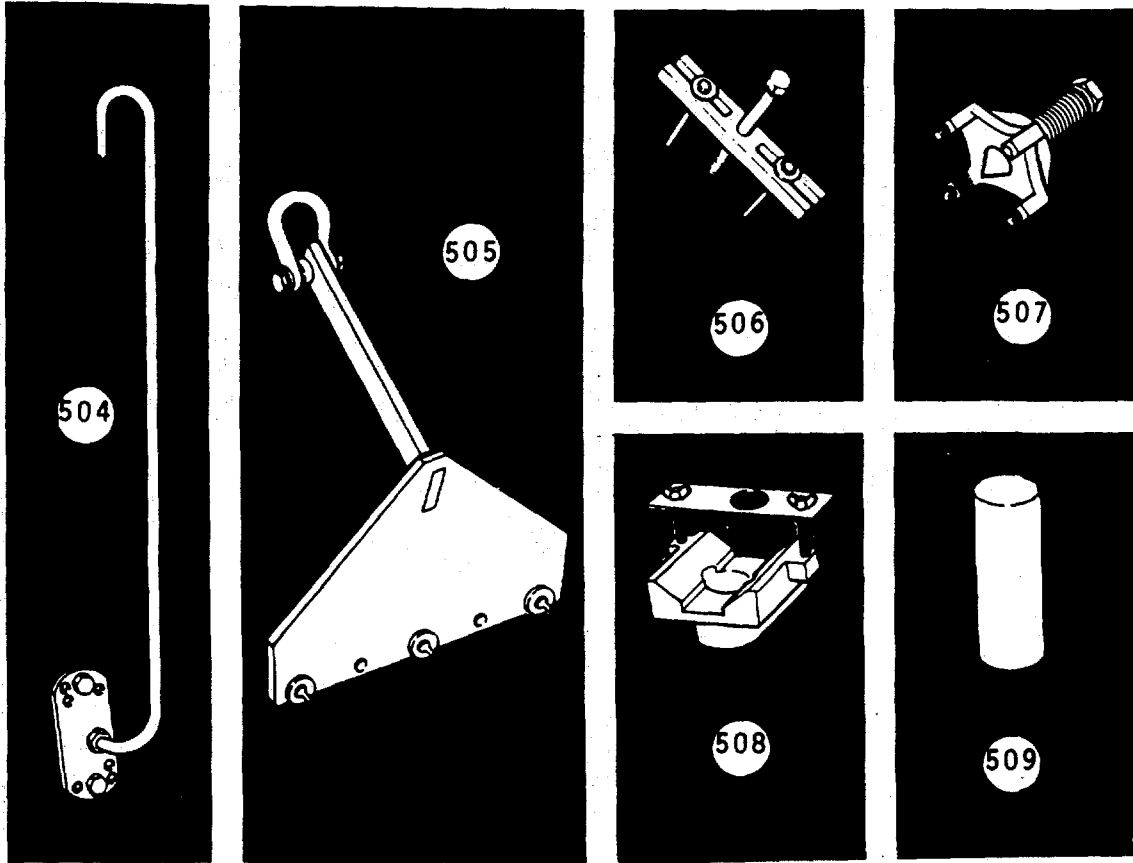

(1) ILLUS NO.	(2) NATIONAL STOCK NUMBER	(3) DESCRIPTION FSCM AND PART NUMBER	(4) USABLE ON CODE U/M	(5) QTY RQR
504	4910-00-722-3877	Lifter, Flywheel (33287) J6361-01	EA	1
505	4910-00-456-7620	Lifting Fixture, Cylinder Head (33287) J22062-01	EA	1
506	5120-00-471-4494	Puller, Crankshaft Pulley (33287) J45558-01	EA	1
507	5120-00-219-8397	Puller, Camshaft Gear (33287) J1902-01	EA	1
508	4910-00-779-6163	Reaming Fixture, Piston Bushing (33287) J5273	EA	1
509	5120-00-363-7572	Remover, Water Pump Coupling & Oil Seal (33287) J1930	EA	1

SECTION III. BASIC ISSUE ITEMS LIST (CONTINUED)

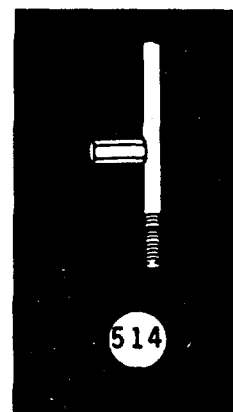
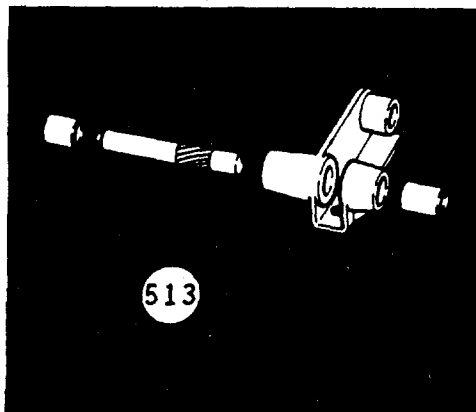
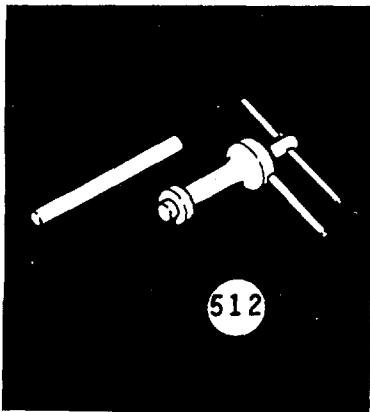
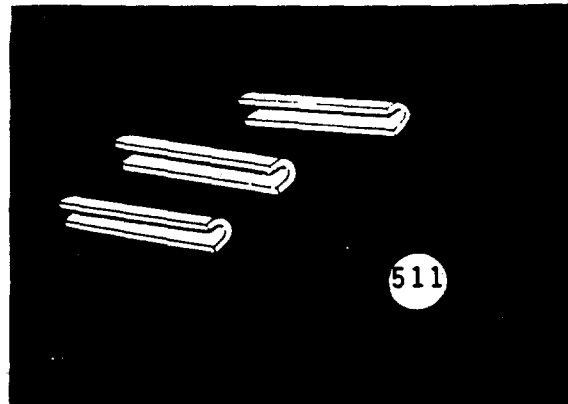
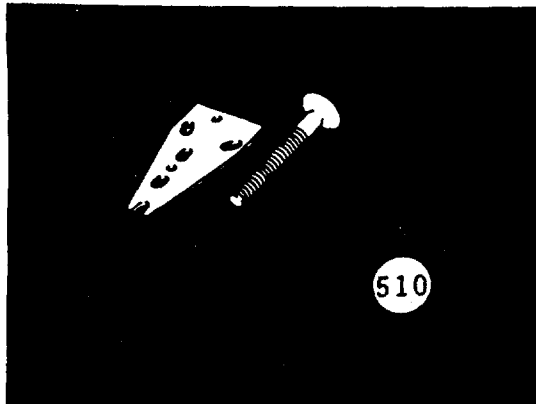

(1) ILLUS NO.	(2) NATIONAL STOCK NUMBER	(3) DESCRIPTION FSCM AND PART NUMBER	(4) USABLE ON CODE U/M	(5) QTY RQR
510	2040-01-057-6267	Remover, Water Pump Impeller (33287) J22143	EA	1
511	5120-00-494-1843	Remover Set, Push Rod (33287) J3092-01	EA	1
512	5120-00-999-8613	Remover, Valve Seat Insert (33287) J6567-02	EA	1
513	4910-00-219-8392	Reamer Set, Connecting Rod Rushing (33287) J1686-03	EA	1
514	5120-00-937-7632	Remover, Connecting Rod Nozzle (33287) J8995	EA	1

SECTION III. BASIC ISSUE ITEMS LIST (CONTINUED)

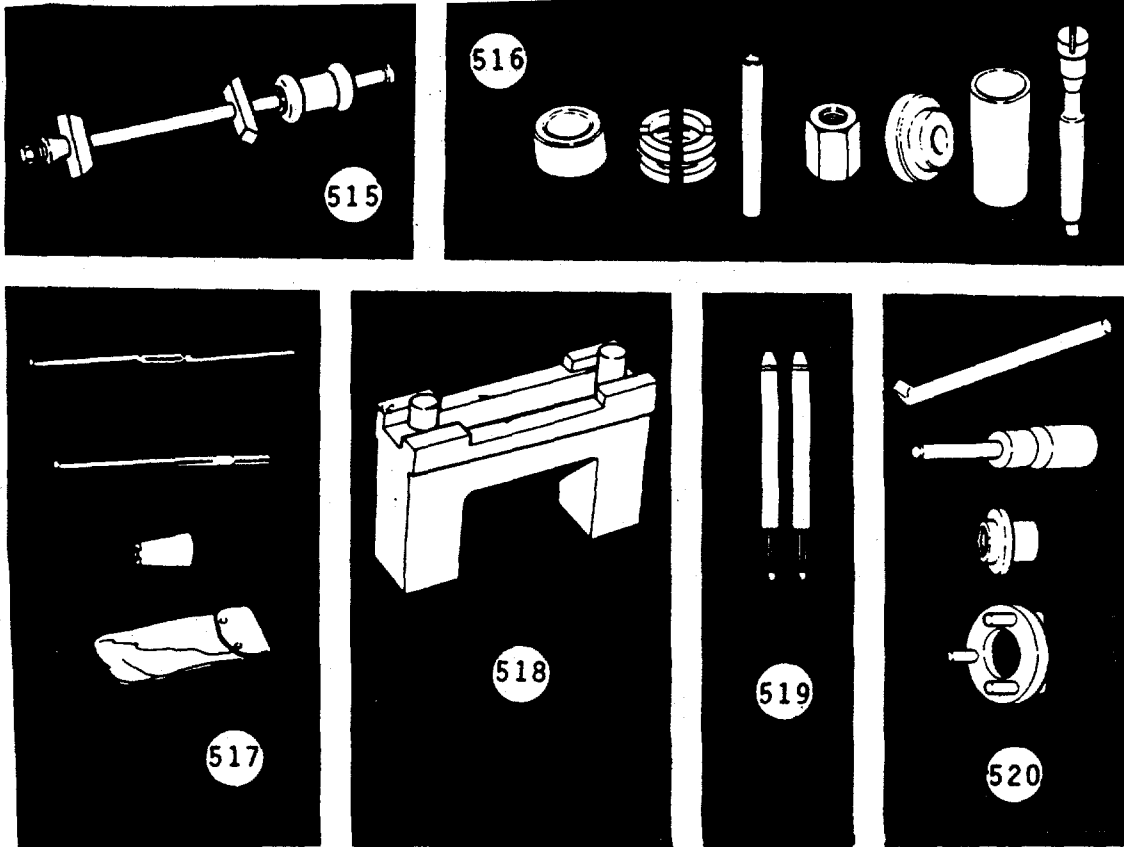

(1) ILLUS NO.	(2) NATIONAL STOCK NUMBER	(3) DESCRIPTION FSCM AND PART NUMBER	(4) USABLE ON CODE U/M	(5) QTY RQR
515	5120-00-387-9615	Remover, Cylinder Liner (33287) J1918-02	EA	1
516	5120-00-113-1004	Remover & Installer Set Blower Rotor Shaft (33287) J4254	EA	1
517	5180-00-113-3168	Reconditioning Kit, Lube Oil Pump (33287) J2624	EA	1
518	2815-00-705-9278	Service Fixture, Cam Follower (33287) J5840-01	EA	1
519	4910-00-591-6634	Stud Set, Guide (33287) J9665	EA	1
520	5180-00-219-8407	Tool Set, Fuel Pump (33287) J1508-02	EA	1

SECTION III. BASIC ISSUE ITEMS LIST (CONTINUED)

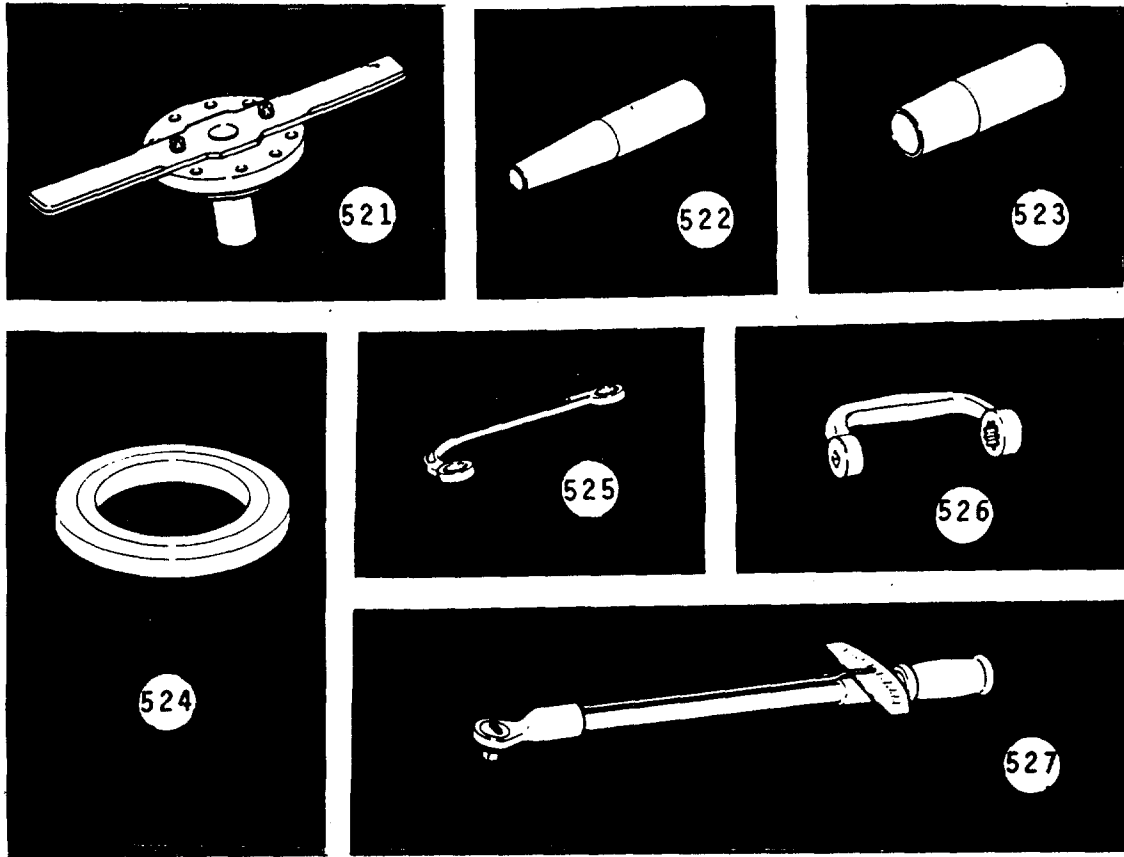

(1) ILLUS NO.	(2) NATIONAL STOCK NUMBER	(3) DESCRIPTION FSCM AND PART NUMBER	(4) USABLE ON CODE U/M	(5) QTY RQR
521	5120-00-893-4995	Tool, Lock Testing (01843) TSE8606	EA	1
522		Tool, Push (01843) EHS41-3858	EA	1
523	5120-01-071-3037	Tool, Push (01843) EHS41-2858	EA	1
524		Tool, Shaft Seal Aligning (58849)	EA	1
525	5120-00-591-2685	Wrench, Fuel & Water Pump (33287) J4242	EA	1
526	5120-01-013-1677	Wrench, Cylinder head (33287) J1928-01	EA	1
527	5120-00-247-2540	Wrench, Torque, 1/2" Drive 0-300 ft.lbs. (81348) GGG-W-00686	EA	1

SECTION III. BASIC ISSUE ITEMS LIST (CONTINUED)

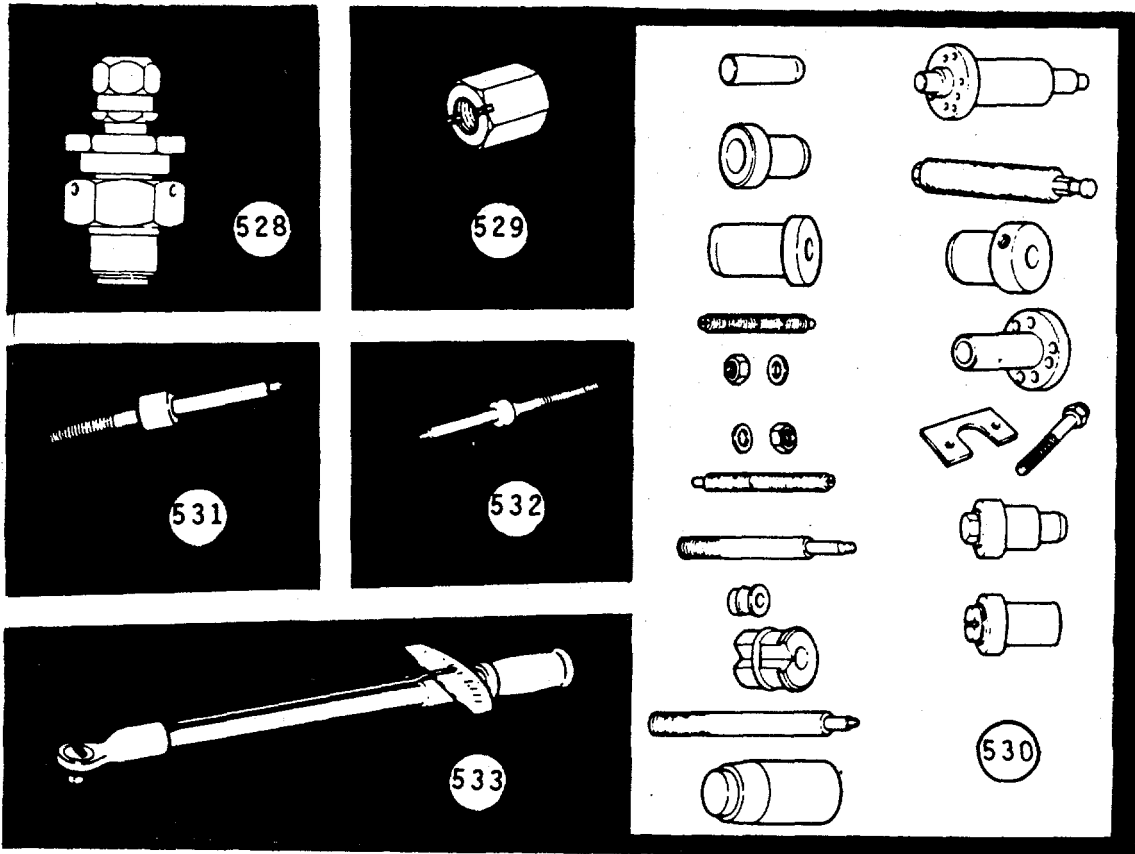

(1) ILLUS NO.	(2) NATIONAL STOCK NUMBER	(3) DESCRIPTION FSCM AND PART NUMBER USABLE ON CODE	(4) U/M	(5) QTY RQR
528	4820-00-535-6483	Valve, Charging (96906) MS28889-1	EA	1
529	5120-00-627-9311	Wrench Gov Retainer Nut (33287) J1652-01	EA	1
530	4940-00-611-7945	Tool Set Blower Service (33287) J6270-04	EA	1
531	5210-00-474-6400	Timing Gage, INJ 1.484 (33287) J1242	EA	1
532	5220-00-387-9581	Timing Gage, INJ 1.460 (33287) J1853	EA	1
533	5120-00-221-7983	Wrench Torque 3/4 inch Drive 0-600 ft.lbs.	EA	1

SECTION III. BASIC ISSUE ITEMS LIST (CONTINUED)

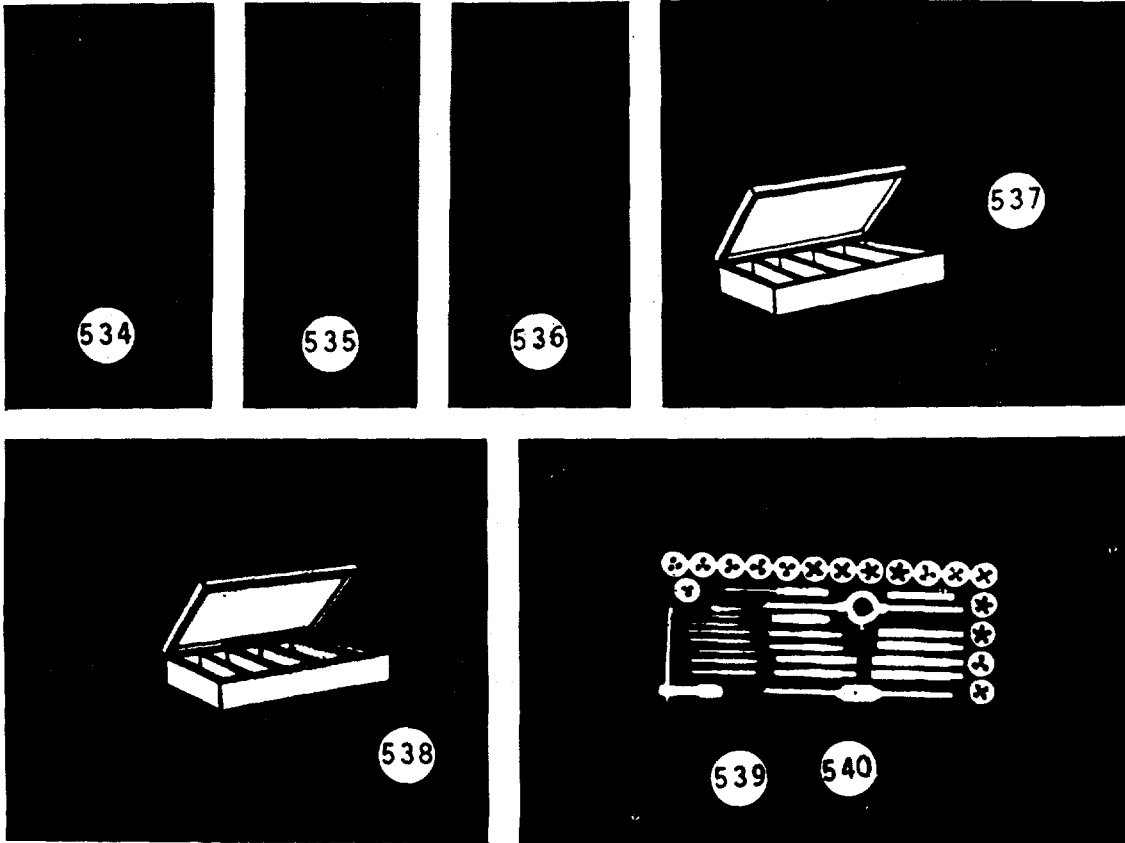

(1) ILLUS NO.	(2) NATIONAL STOCK NUMBER	(3) DESCRIPTION FSCM AND PART NUMBER	(4) U/M	(5) QTY RQR
534	5850-00-407-6671	Signal Lamp. Aldis, SE 11 (80063)	EA	1
535		Sprayer, Insecticide, Hand, 2 gallon		
536	5680-00-351-9702	Tachometer, Mechanical 1412 (57737)	EA	1
537	6630-00-074-0394	Test Kit, Chromate 12100 (71881)	EA	2
538	6630-00-531-1968	Test Kit, Oil Conditioning (531 Components) T-19467 (81349)	EA	2
539	5180-00-357-7514	Threading Set, Pipe, 1/8 inch to 1 inch GGG-T-581 (81348)	EA	1
540	5180-00-387-9631	Threading Set, Pipe, 1-1/4-11-1/2 NPT	EA	1

SECTION III. BASIC ISSUE ITEMS LIST (CONTINUED)

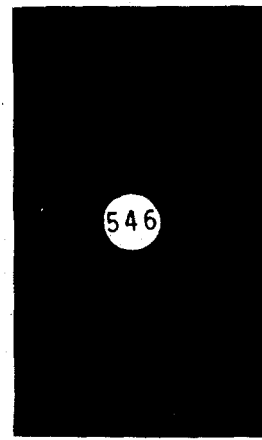
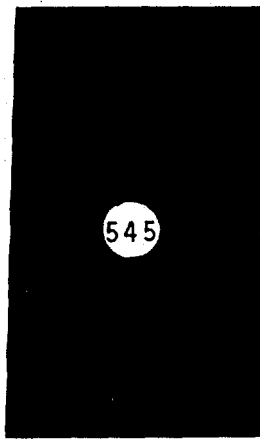
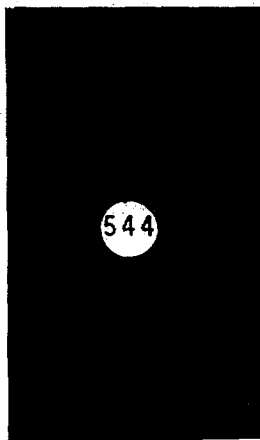
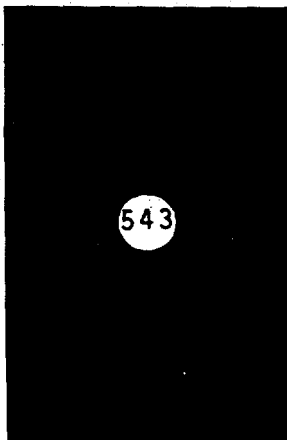
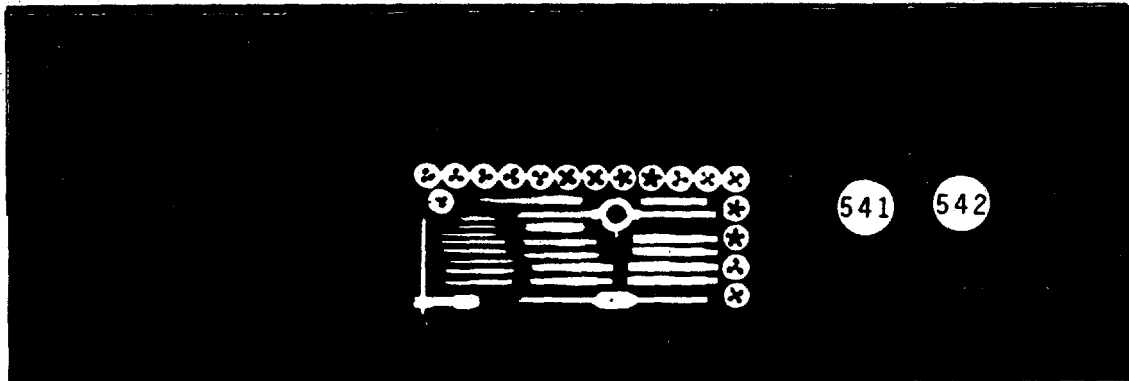

(1) ILLUS NO.	(2) NATIONAL STOCK NUMBER	(3) DESCRIPTION FSCM AND PART NUMBER	USABLE ON CODE	(4) U/M	(5) QTY RQR
541	5180-00-448-2362	Threading Set, Screw 1/4-20 to 1-8 NC		EA	1
542	5180-00-422-4975	Threading Set, Screw, 1/4-28 to 1-12 NF & 1-14 NS		EA	1
543	5180-00-356-4614	Tool Kit, TK-61/SR		EA	1
544	5180-00-293-2875	Tool Kit, Carpenters		EA	1
545	5180-00-629-9783	Tool Kit, General Mechanics, Marine SC5180-97-CL-E28		EA	2
546	5180-00-511-1950	Tool Kit, Machinist		EA	1

SECTION III. BASIC ISSUE ITEMS LIST (CONTINUED)

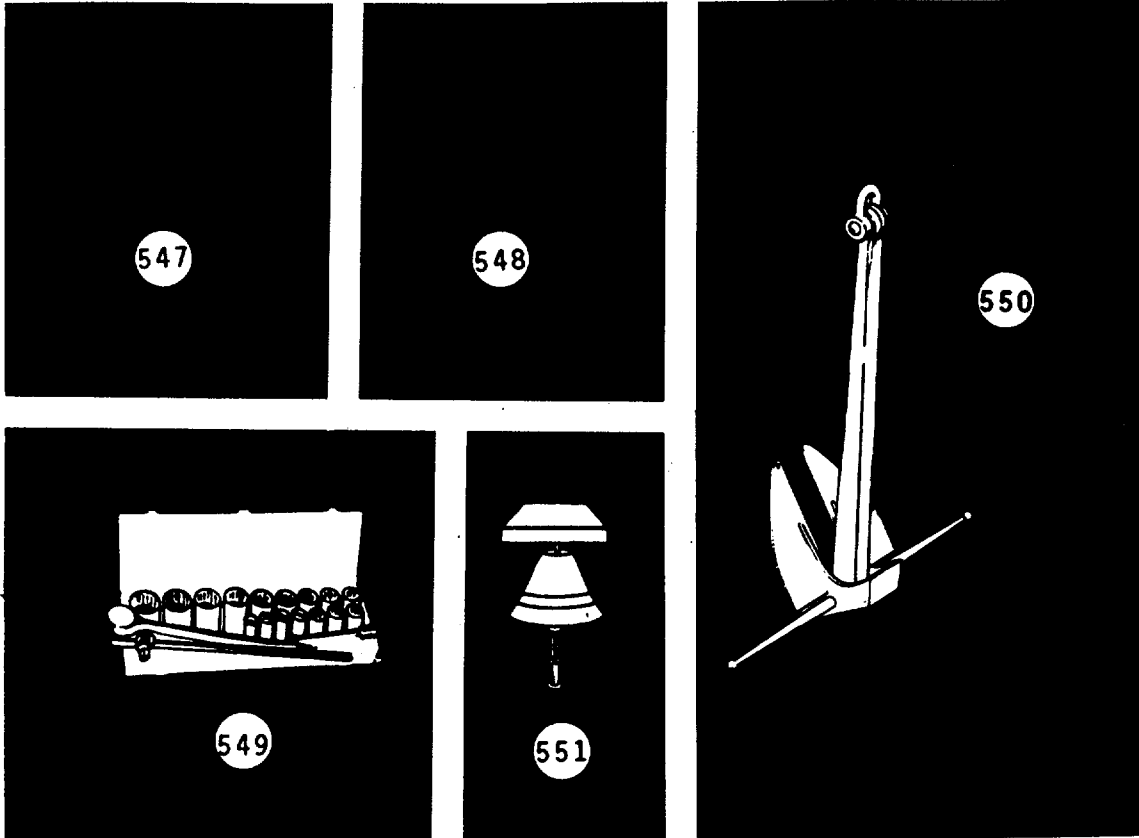

(1) ILLUS NO.	(2) NATIONAL STOCK NUMBER	(3) DESCRIPTION FSCM AND PART NUMBER	(4) USABLE ON CODE U/M	(5) QTY RQR
547	3433-00-357-8116	Torch Outfit, Cutting and Welding, Medium Duty, Oxy-Acetylene	EA	1
548	6645-00-250-4680	Watch, Stop, 60 Second Dial GG-S-764 (81348)	EA	1
549	5120-00-204-1999	Wrench Set, Socket, 3/4 inch, Square Drive 12 PT 7/8 to 2 inches	EA	1
550	2040-00-377-8607	Anchor, Removable Stock, LWT A15707 (81349)	EA	1
551	6350-00-256-9062	Bell, Ships, 30 lb. "A" Flat MIL-B-674 (81349)	EA	1

SECTION III. BASIC ISSUE ITEMS LIST (CONTINUED)

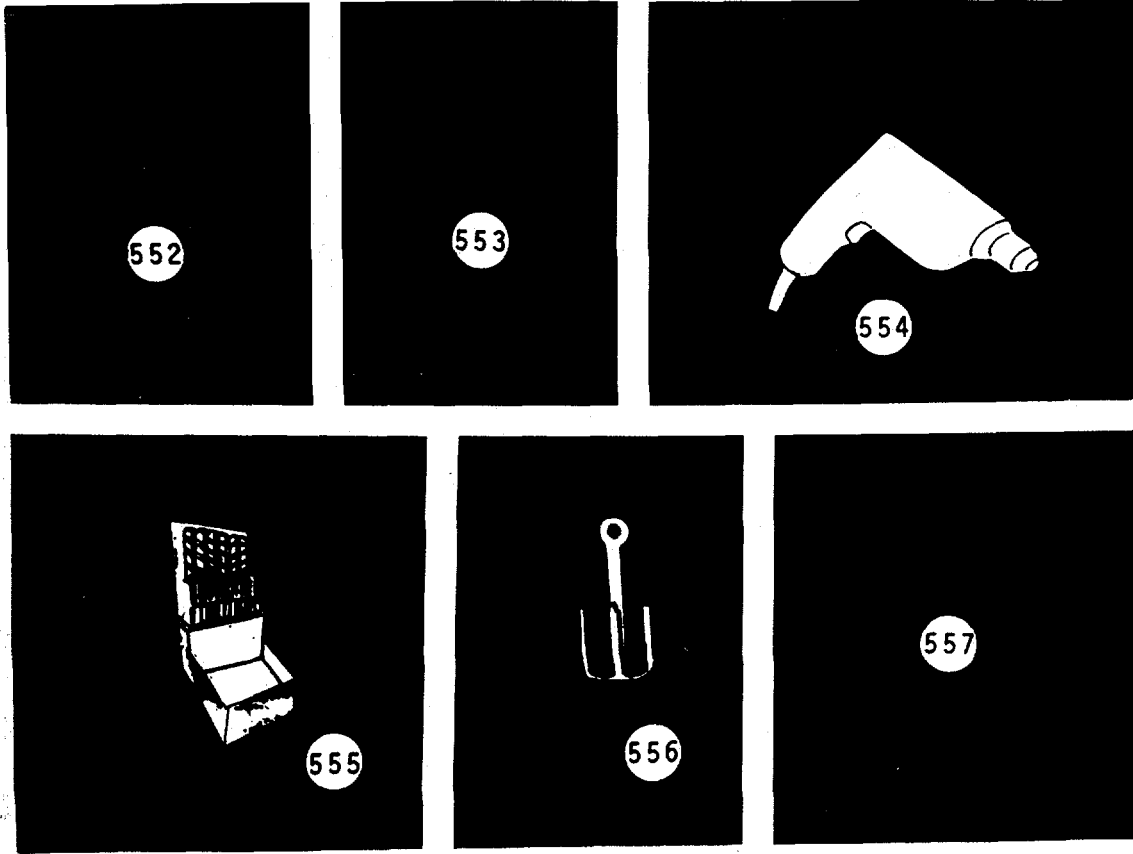

(1) ILLUS NO.	(2) NATIONAL STOCK NUMBER	(3) DESCRIPTION FSCM AND PART NUMBER	(4) USABLE ON CODE U/M	(5) QTY RQR
552	7210-00-282-7950	Blanket, Wool, OD, B-844 (81349)	EA	28
553	6665-00-618-1482	Detector Kit, Carbon Monoxide, Colometric	EA	1
554	5130-00-853-4480	Drill, Electric 1/2 inch AC/DC WD-661 (81348)	EA	1
555	5133-00-293-0983	Drill Set, Twist, HSS, ST, Rd Shank, Rn cut, w/case	EA	1
556	2040-00-238-9060	Grapnel, Marine, Iron or Steel, Galv, Prong 15 lb.	EA	1
557	3940-00-150-7108	Hoist, Chain, Hand, 3/4 Ton, 10 feet, Load Chain, Lever, and Ratchet	EA	2

SECTION III. BASIC ISSUE ITEMS LIST (CONTINUED)

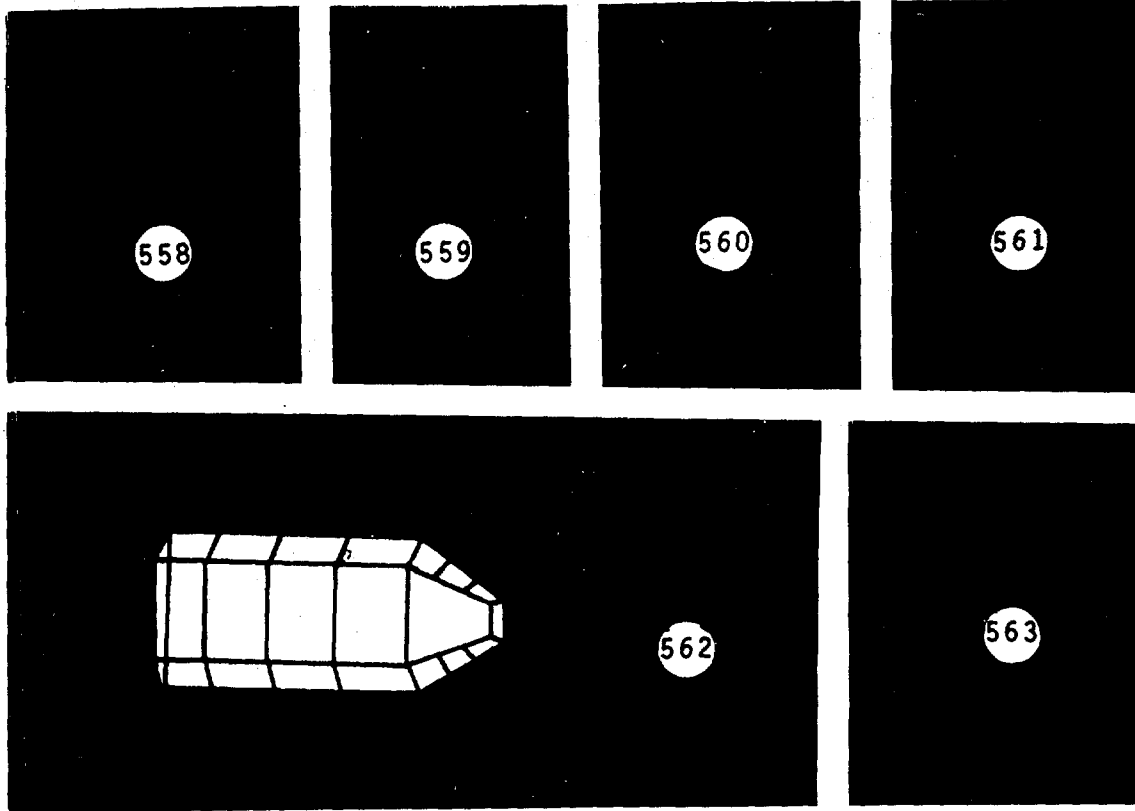

(1) ILLUS NO.	(2) NATIONAL STOCK NUMBER	(3) DESCRIPTION FSCM AND PART NUMBER USABLE ON CODE	(4) U/M	(5) QTY RQR
	3950-00-235-4236	Hoist, Chain, Hand 1-1/2 Ton, 10 feet, 1 Load Chain, Lever, and Ratchet	EA	1
559	3950-00-965-0096	Hoist, Chain, Hand, 2 Ton 12 feet, 1 Load Chain, Spur Gear	EA	1
560	4720-00-202-6482	Hose Assy, Rubber, Wrap, Water, 3/4 inch Female Hose Fitting, 14 NPSH, 50 ft. Long	EA	2
561	4210-00-078-9170	Hose, Fire, 1-1/2 in. NH, 1-1/2 in. ID, 50'	EA	4
562	6530-00-783-7810	Litter, Rigid, Stokes	EA	1
563	7210-00-292-2326	Pillowcase, Bed DDD-P-351-(81348)	EA	28

SECTION III. BASIC ISSUE ITEMS LIST (CONTINUED)

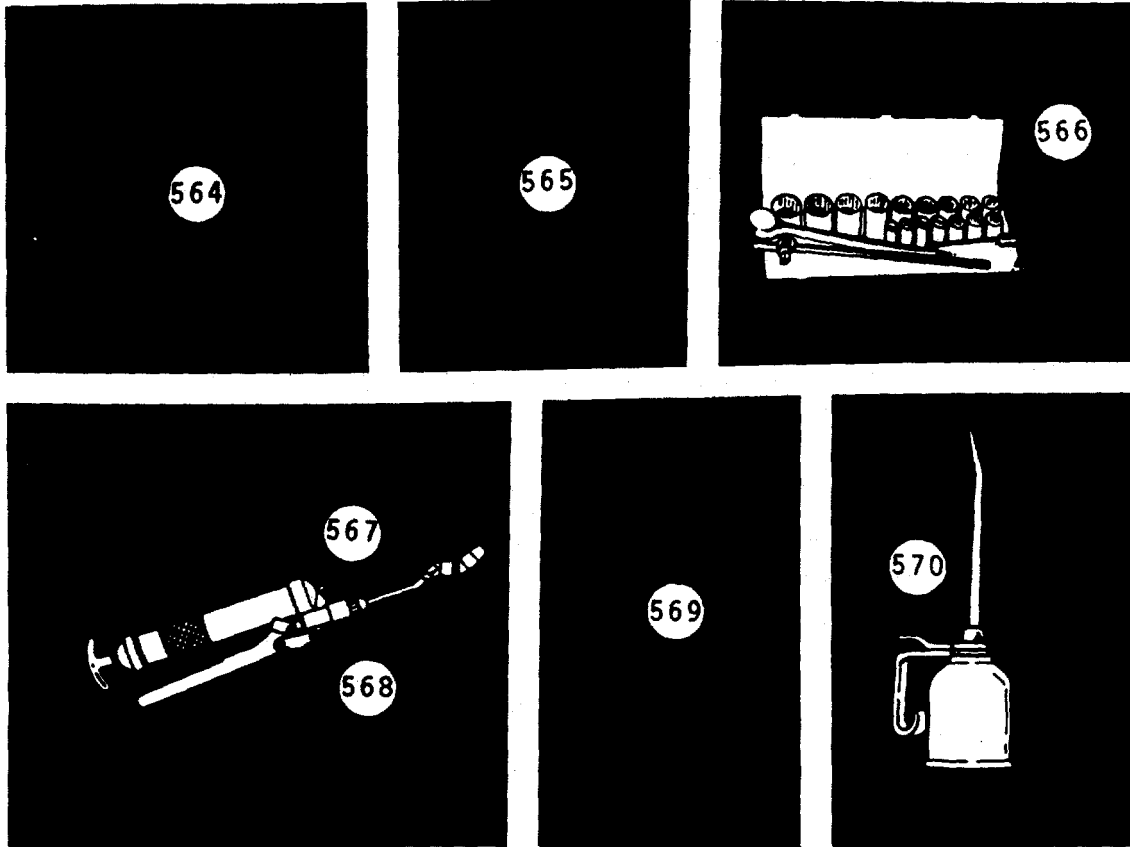

(1) ILLUS NO.	(2) NATIONAL STOCK NUMBER	(3) DESCRIPTION FSCM AND PART NUMBER USABLE ON CODE	(4) U/M	(5) QTY RQR
564	4220-00-285-3157	Ring, Buoy, Floating, 30 inch OD w/Line R-116847 (81349)	EA	10
565	6605-00-001-4322	Sextant, Marine, MK3, MOD1 9240-001 (12004)	EA	1
566	5120-00-357-5135	Wrench Set, Socket, Sq Drive, 3/4 inch Across Flats, Hex Type Sockets	EA	1
567	4930-00-253-2478	Grease Gun, Hand, 16 oz cap	EA	1
568	4930-00-287-5419	Gun, Fluid (Grease), Dir. Del. 30 oz Cap.	EA	1
569	6230-00-828-6398	Lantern, elcl, 6V, w/Relay	EA	5
570	4930-00-262-8868	Oiler, Hand, Flex Spout 1 pt GGG-0-591 (81348)	EA	2

SECTION III. BASIC ISSUE ITEMS LIST (CONTINUED)

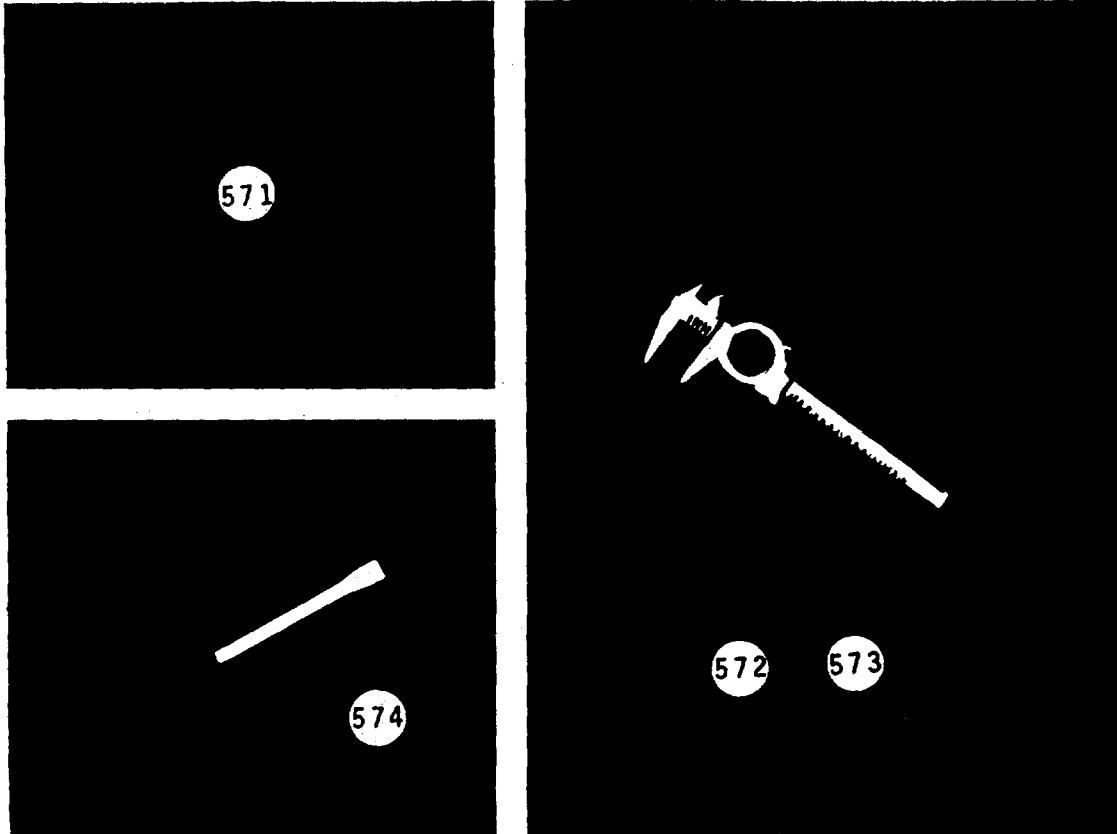

(1) ILLUS NO.	(2) NATIONAL STOCK NUMBER	(3) DESCRIPTION FSCM AND PART NUMBER	USABLE ON CODE	(4) U/M	(5) QTY RQR
571	5120-00-293-0762	GGG-B-101, Type V, Class 1, Style B (81348)	Bar, Wrecking, 36 inches	EA	1
572	5210-00-554-7134	GG-C-105, Type 1, Class 1, Style A, (81348)	Caliper Set, Micrometer	EA	1
573	5210-00-221-1921	GGG-C-105, Type 1, Class 2 (81348)	Caliper Set Micrometer Inside 2 to 12 in.	EA	1
574	5110-00-554-7345	GGG-C-313 Type 1 Style B (81348)	Chisel, Cape, 1/2 x 6 3/4 in.	EA	1

SECTION III. BASIC ISSUE ITEMS LIST (CONTINUED)

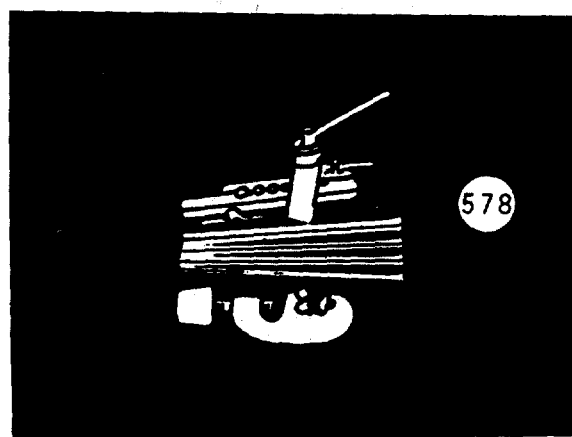
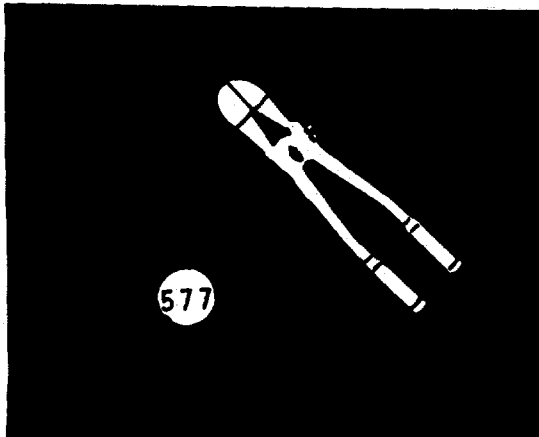
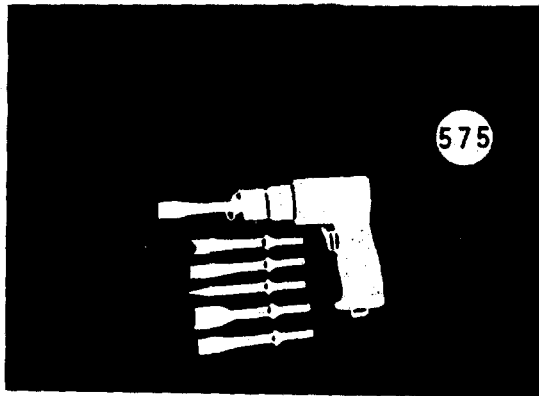

(1) ILLUS NO.	(2) NATIONAL STOCK NUMBER	(3) DESCRIPTION FSCM AND PART NUMBER	USABLE ON CODE	(4) U/M	(5) QTY RQR
575	5110-00-203-6424	GGG-C-330 Type XV, Class A (81348)	Chisel, Power Hammer	EA	2
576	5120-00-529-3744	GGG-C-406 Type 1, Style 1, Class D (81348)	Clamp "C" heavy 9 ER 1165	EA	2
577	5110-00-188-2524	GGG-C-740 Class 4 (81348) 36 inch	Cutter, Bolt	EA	1
578	5180-00-596-1035	GGG-C-771, Type 2, Class 1 (81348)	Cutting & Flaring Tool Kit	EA	1

SECTION III. BASIC ISSUE ITEMS LIST (CONTINUED)

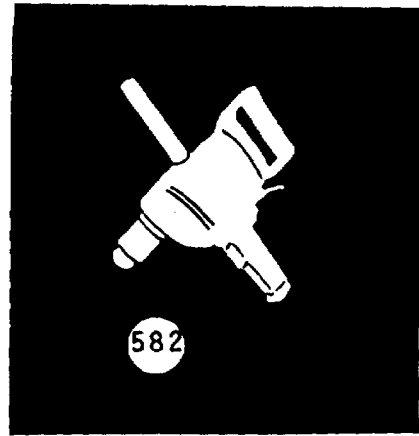
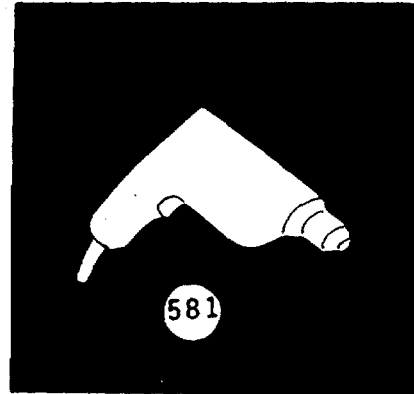
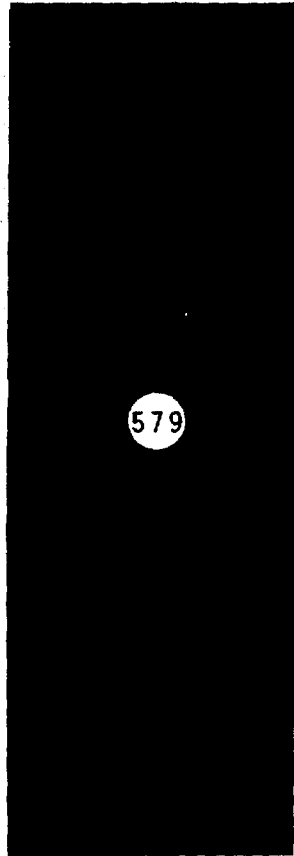
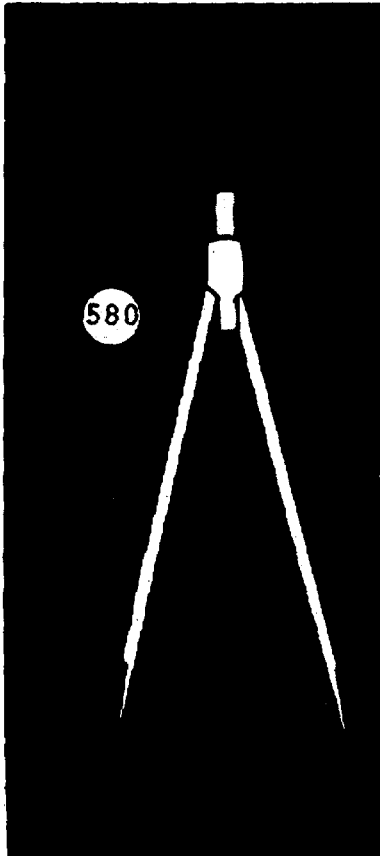

(1) ILLUS NO.	(2) NATIONAL STOCK NUMBER	(3) DESCRIPTION FSCM AND PART NUMBER	USABLE ON CODE	(4) U/M	(5) QTY RQR
579	5110-00-293-0460	GGG-C-771, Type 1, Class 1 Style B (81348)	Cutter Pipe 1/8 in.- 2 in.	EA	1
580	5210-00-266-7038	GGG-D-351, Type A, Class 2 (81348) Ring-Type	Dividers, Mechanics,	EA	1
581	5130-00-473-6224	W-D-661, Class C Style 1 (81348)	Drill Elcl Prbl. 3/8 inch cap	EA	1
582	5130-00-226-5386	W-D-1114, Style 4 (81348)	Drill Elcl, Prbl 112 in. cap	EA	1

SECTION III. BASIC ISSUE ITEMS LIST (CONTINUED)

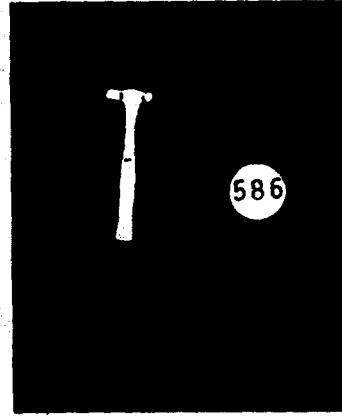
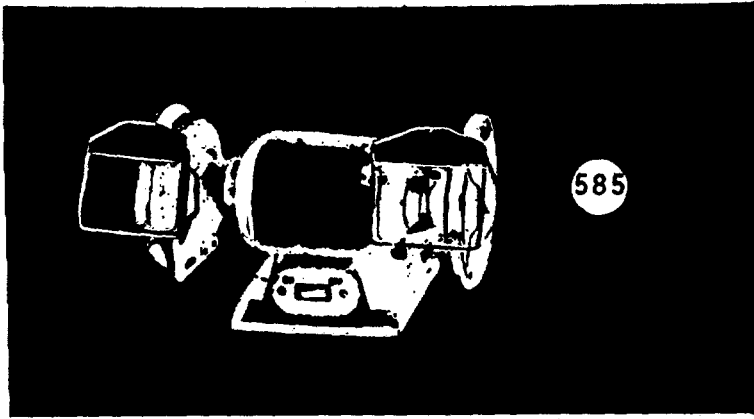
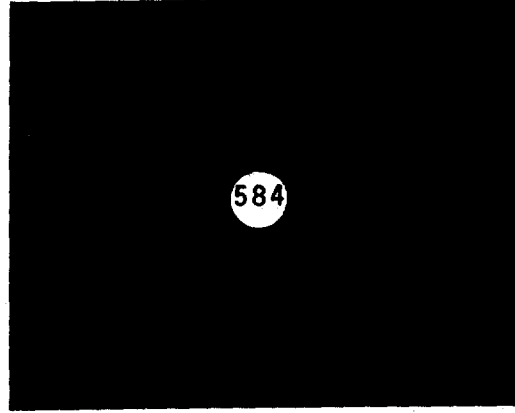
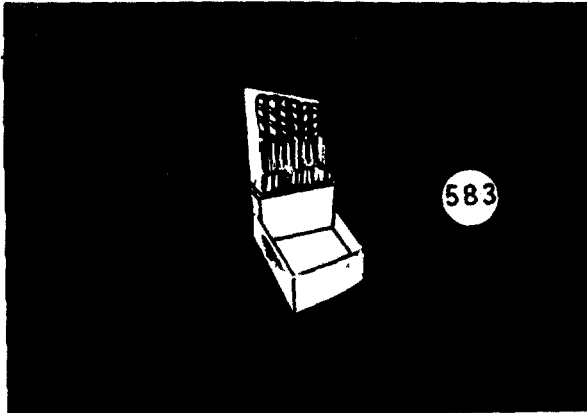

(1) ILLUS NO.	(2) NATIONAL STOCK NUMBER	(3) DESCRIPTION FSCM AND PART NUMBER	USABLE ON CODE	(4) U/M	(5) QTY RQR
583	5136-00-293-0983	GGG-D-751 (81348)	Drill Set, Twist Set # 2	EA	2
584	6230-00-268-9246	XP162 (83303)	Droplight, Explosion- Proof	EA	1
585	3415-00-243-1456	NO REF (33333)	Grinding Machine Bench	EA	1
586	5120-00-224-4111	GGG-H-886 (81348)	Mtd 115 VAC Hammer, Hand, Sealing	EA	4

SECTION III. BASIC ISSUE ITEMS LIST (CONTINUED)

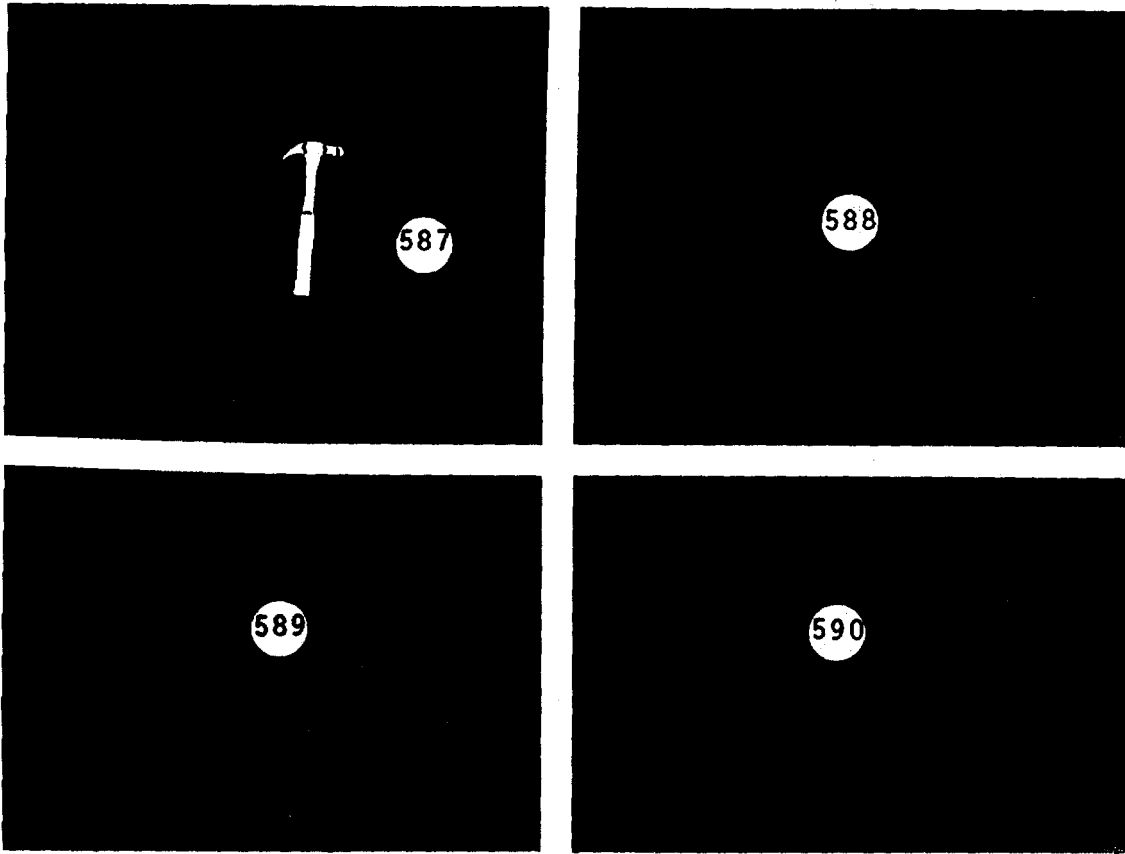

(1) ILLUS NO.	(2) NATIONAL STOCK NUMBER	(3) DESCRIPTION FSCM AND PART NUMBER	USABLE ON CODE	(4) U/M	(5) QTY RQR
587	5120-00-243-2957	GGG-H-86 (81348)	Hammer, Hand 10 lb	EA	1
588	5120-00-061-8546	GGG-H-86 (81348)	Hammer, Hand 24 oz	EA	2
589	5130-00-190-6442	CO-H-116 Type 1, Style A (81348)	Hammer, Pneu- matic Ptbl.	EA	2
590	3950-00-235-4235	NO REF (33333)	Hoist, Chain, Lever & Ratchet	EA	2

SECTION III. BASIC ISSUE ITEMS LIST (CONTINUED)

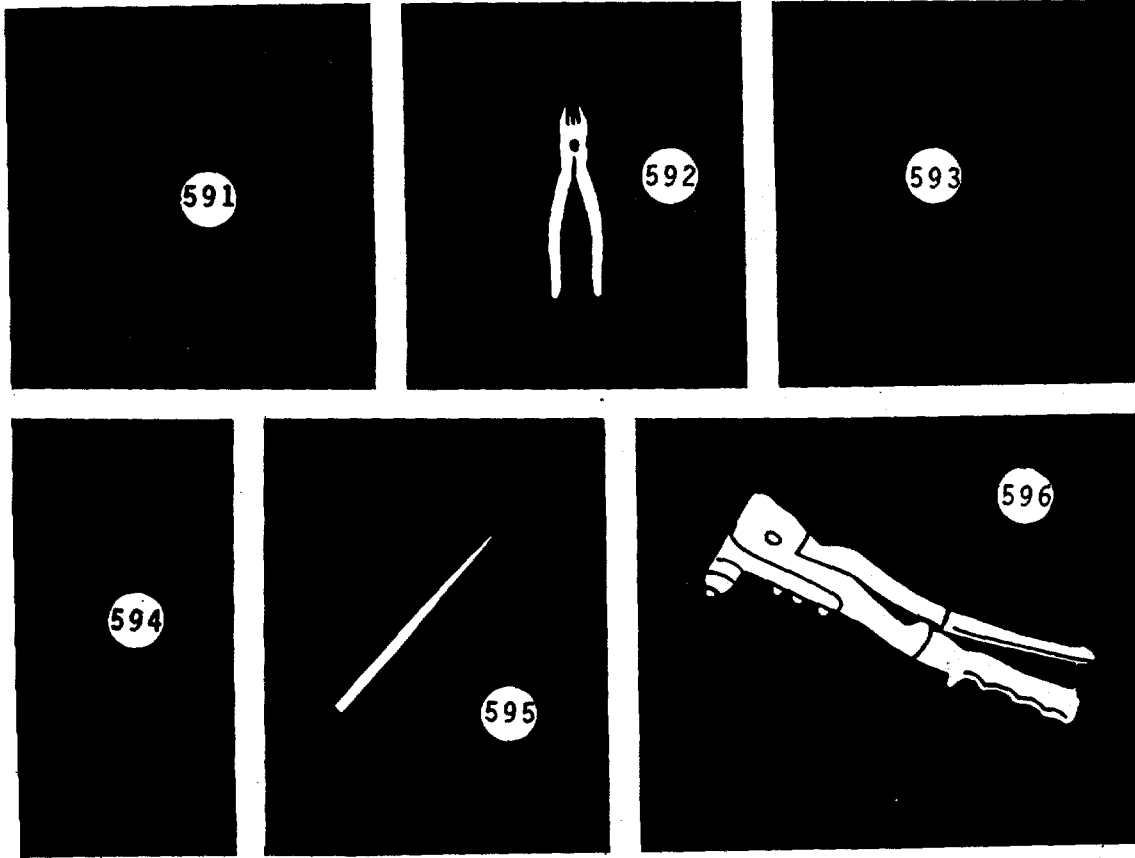

(1) ILLUS NO.	(2) NATIONAL STOCK NUMBER	(3) DESCRIPTION FSCM AND PART NUMBER	USABLE ON CODE	(4) U/M	(5) QTY RQR
591	3950-00-235-4236	NO REF (33333)	Hoist, Chain, Lever & Ratchet	EA	2
592	5120-00-248-9420	GGG-P-471, Type IX Class 2 (81348)	Pliers, Lineman 8 inches	EA	1
593	5120-00-224-9456	W-P-796 Type 1 (81348)	Puller, Fuse, No 2	EA	2
594	5120-00-288-7710	GGG-P-781 Type 1, Class 1	Puller, Mechan- ical 0-7 in.	EA	2
595	5110-00-449-7313	HP7 (45225)	Punch Set, Hand	EA	1
596	5120-00-017-2849	GGG-R-00395 (81348)	Riveter, Blind Hand	EA	1

SECTION III. BASIC ISSUE ITEMS LIST (CONTINUED).

(1) ILLUS NO.	(2) NATIONAL STOCK NUMBER	(3) DESCRIPTION FSCM AND PART NUMBER	USABLE ON CODE	(4) U/M	(5) QTY RQR
597	5130-00-226-5387	00-S-116, Type II, Style 1 (81348)	Sander, Disc. Elcl Ptbl, Sz 7	EA	2
598	5120-00-278-1280	GGG-S-121, Type 1, Design	Screwdriver Flat Tip, 8 in.	EA	2
599	5120-00-293-3309	GGG-S-121, Type 1, Design A (81348)	Screwdriver flat tip 10 inches	EA	2
600	5120-00-542-3438	GGG-S-121, Type VI, Class 6 (81348)	Screwdriver Cross Tip No. 2-8 inch	EA	2

SECTION III. BASIC ISSUE ITEMS LIST (CONTINUED)

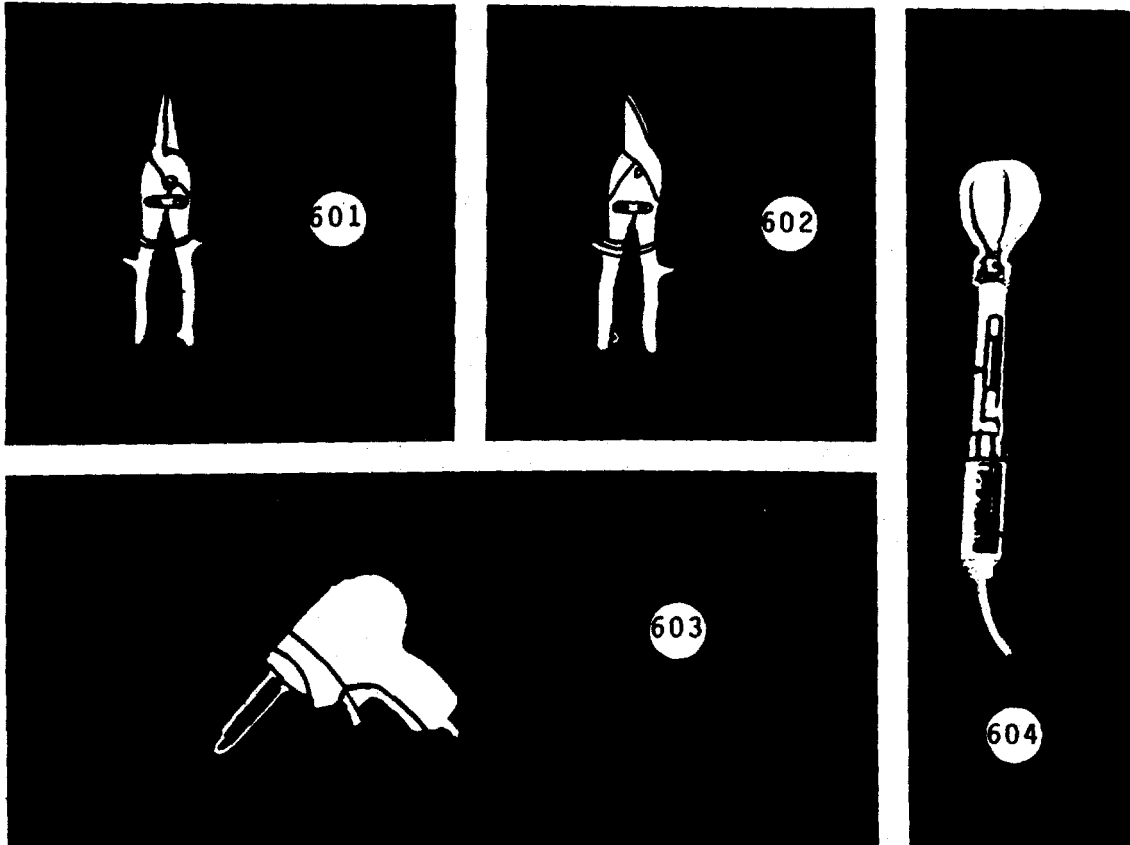

(1) ILLUS NO.	(2) NATIONAL STOCK NUMBER	(3) DESCRIPTION FSCM AND PART NUMBER	USABLE ON CODE	(4) U/M	(5) QTY RQR
601	5110-00-221-1087	GGG-S-291, Class 3 (81348)	Shears, Metal Cutting Straight Cut	EA	1
602	5110-00-223-5370	GGG-S-278 Type 1, Class 4 (81348)	Shears, Tailors	EA	1
603	3439-00-542-0531	450K4 (11103)	Soldering Gun Kit, Elcl	EA	1
604	6630-00-171-5126	GGG-T-258 Class 1 Style B (81348)	Tester, Batt Electrolite Solution	EA	1

SECTION III. BASIC ISSUE ITEMS LIST (CONTINUED)

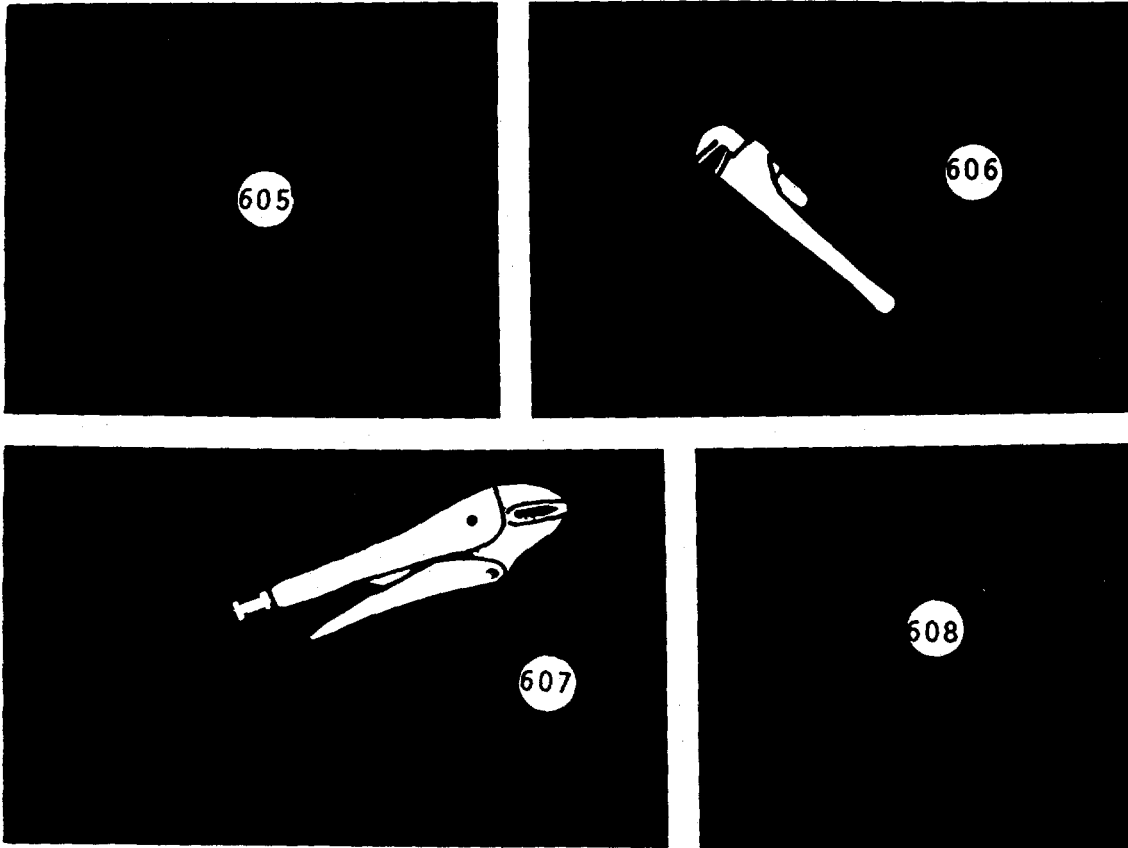

(1) ILLUS NO.	(2) NATIONAL STOCK NUMBER	(3) DESCRIPTION FSCM AND PART NUMBER	USABLE ON CODE	(4) U/M	(5) QTY RQR
605	5130-00-857-8522	600-S-90 (81348) AC/DC	Sander, Disc Eicl Portable	EA	1
606	5120-00-277-1462	GGG-W-651 Type 2 Class A	Wrench Pipe 24 inches	EA	2
607	5120-00-277-4244	GGG-W-649 Type 1 Class 1 Style A (81348)	Wrench Plier, 8 1/2 inches	EA	2
608	5120-00-288-6488	GGG-W-665 Type 1 Class 1 (81348)	Wrench, Spanner fixed pivot point adjust- able hook 3/4 in. - 2 in.	EA	6

SECTION III. BASIC ISSUE ITEMS LIST (CONTINUED)

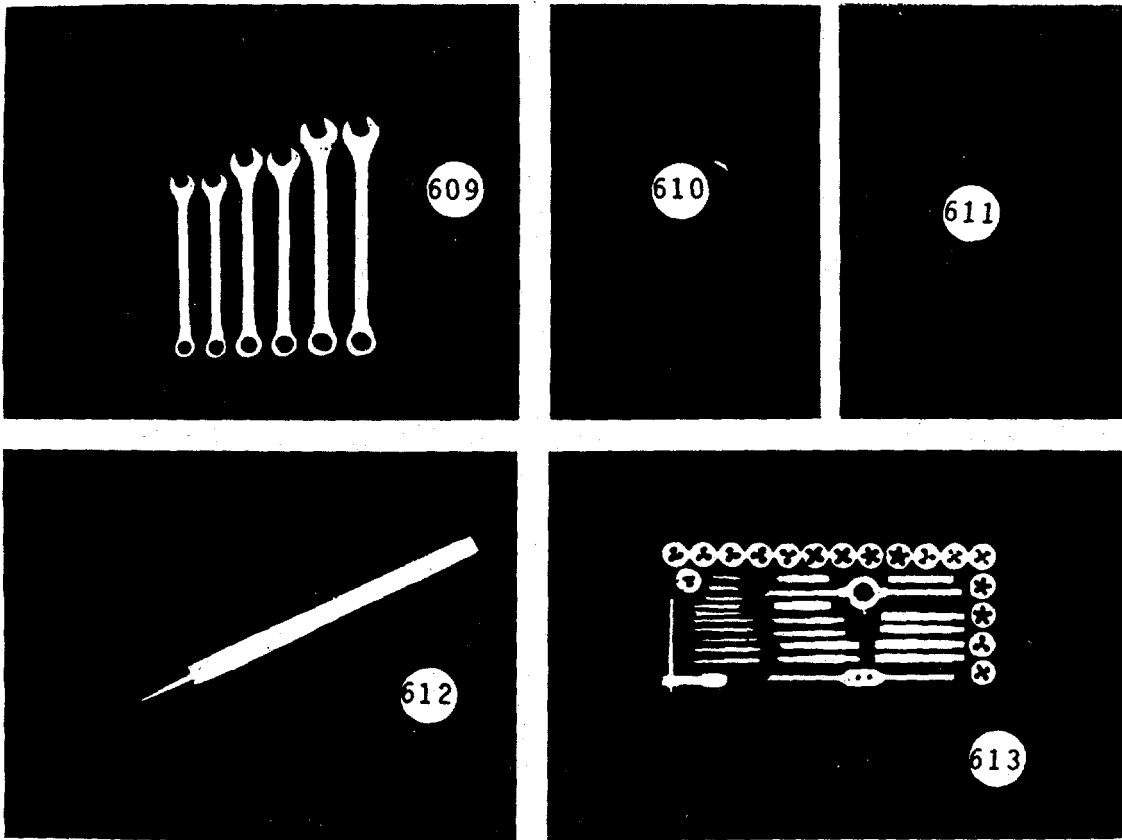

(1) ILLUS NO.	(2) NATIONAL STOCK NUMBER	(3) DESCRIPTION FSCM AND PART NUMBER	USABLE ON CODE	(4) U/M	(5) QTY RQR
609	5120-00-935-7333	OEXM709 (55719)	Wrench Set, Comb. Box & Open-end Metric	EA	1
610	5120-00-224-9453	W-P-796, Type 1	Puller, Fuse No. 1	EA	2
611	5130-00-288-6577	MIL-STD-1337	Scaling and Chipping Tool	EA	2
612	5120-00-223-8860	MIL-F-3113	Fid 18 inch	EA	1
613	5180-00-448-2362	GGG-T-300 Type 1 (81348)	Threading Set, Screw 1/2-20 Tol 8 NC	EA	1

SECTION III. BASIC ISSUE ITEMS LIST (CONTINUED)

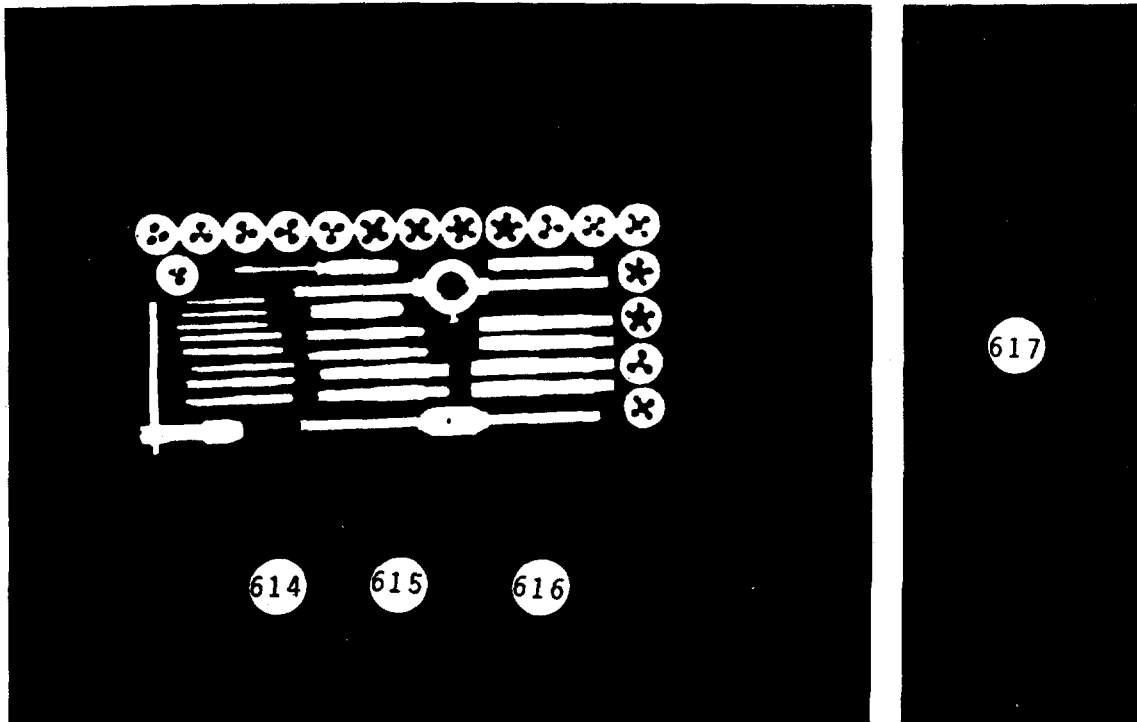

(1) ILLUS NO.	(2) NATIONAL STOCK NUMBER	(3) DESCRIPTION FSCM AND PART NUMBER	USABLE ON CODE	(4) U/M	(5) QTY RQR
614	5180-00-422-4975	GGG-T-330, Type I (81348)	Threading Set Screw 1/4-28 to 1-12 NF	EA	1
615	5180-00-357-7514	GGG-T-581 Type 1 Class 1 Pipe 1/8-1	Threading Set,	EA	1
616	5180-00-387-9631	NO REF (33333)	Threading Set Pipe	EA	1
617	5180-00-926-3552	SC5180-00-97-CL-E49 (81996)	Tool Kit, Air Conditioner	EA	1

SECTION III. BASIC ISSUE ITEMS LIST (CONTINUED).

(1) ILLUS NO.	(2) NATIONAL STOCK NUMBER	(3) DESCRIPTION FSCM AND PART NUMBER	USABLE ON CODE	(4) U/M	(5) QTY RQR
618	5180-00-629-9783	SC578000-97-CL-E28 (81996)	Tool Kit, General Mech. Rail & Marine	EA	2
619	5180-00-691-1165	5144 (00624)	Tool Kit Hydraulic Hose	EA	
620	5180-00-596-1474	SC5180-00-97-CL-E18 (81996)	Tool Kit, Service Re- frigeration	EA	1
621	3439-00-542-0531	GGG-T-570 (81348)	Torch Kit, Soldering LP Gas	EA	1

SECTION III. BASIC ISSUE ITEMS LIST (CONTINUED).

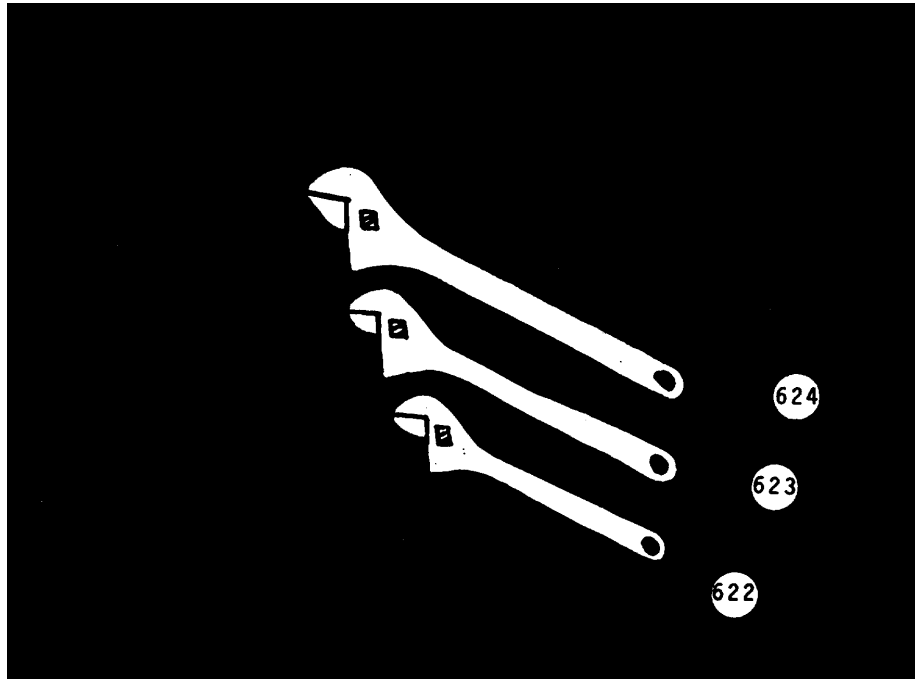

(1) ILLUS NUMBER	(2) NATIONAL STOCK NUMBER	(3) DESCRIPTION FSCM and Part Number	Usable On Code	(4) U/M	(5) Qty rqr
622	5120-00-24-5328	GGG-W-631 Type C Class A Size 8 (81348)	Wrench, Adjustable 7 1/2 to 8 1/2	EA	2
623	5120-00-449-8083	GGG-W-631 Type C Class A Size 10 (81348)	Wrench, Adjustable 9 1/2 to 10 1/2	EA	2
624	5120-00-264-3796	GGG-W-631 Type C Class A Size 12 (81348)	Wrench Adjustable 11 1/2 to 12.1/2	EA	2

SECTION III. BASIC ISSUE ITEMS LIST (CONTINUED).

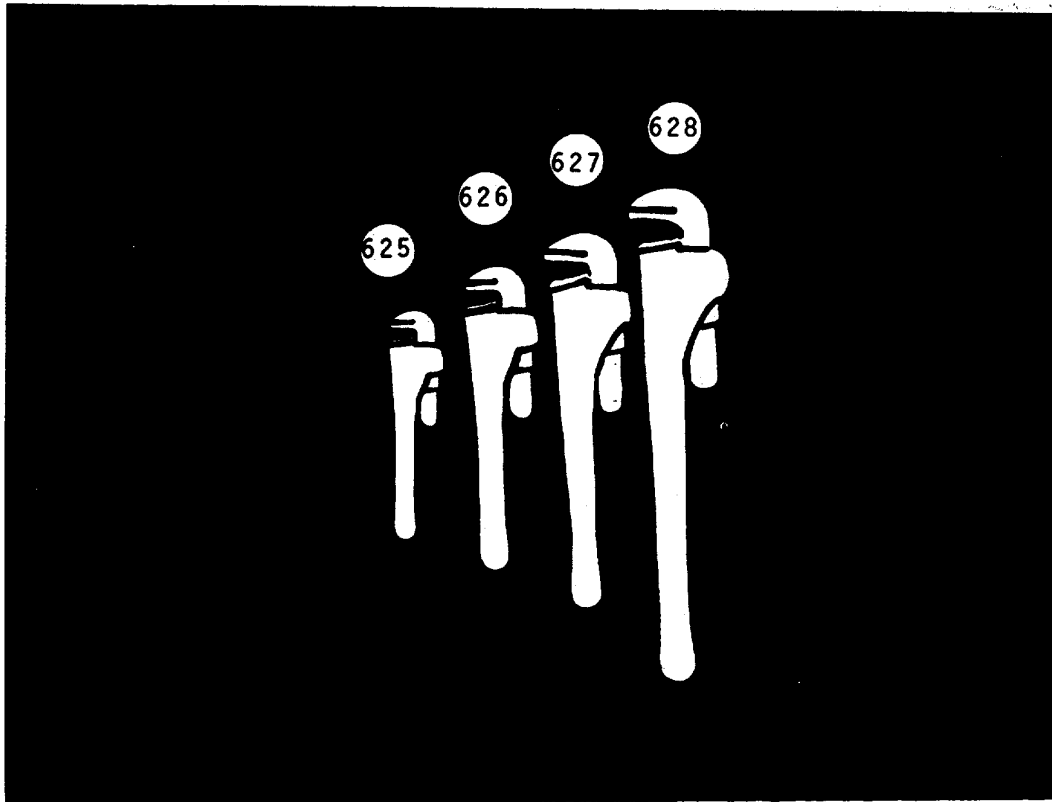

(1) ILLUS NUMBER	(2) NATIONAL STOCK NUMBER	(3) DESCRIPTION FSCM and Part Number	Usable On Code	(4) U/M	(5) Qty rqr
625	5120-00-277-1484	GGG-W-651 Type 2, Class A (81348)	Wrench Pipe 8 inch	EA	1
626	5120-00-277-1485	GGG-W-651 Type 2, Class A (81348)	Wrench Pipe 10 inch	EA	1
627	5120-00-277-1486	GGG-W-651 Type 2, Class A (81348)	Wrench Pipe 14 inch	EA	2
628	5120-00-277-1461	GGG-W-651 Type 2, Class A (81348)	Wrench Pipe 18 inch	EA	2

SECTION III. BASIC ISSUE ITEMS LIST.

(REFERENCE PUBLICATIONS)

	DESCRIPTION
TM55-1905-220-20P	Organizational, Repair Parts and Special Tools List for Landing Craft, Utility, Design LCU 1671 (NSN 1905-01-009-1056).
TM55-1905-220-34P	Direct Support and General Support Repair Parts and Special Tools for Landing Craft Utility, Design LCU 1671 (NSN 1905-01-009-1056).
TM55-1905-220-14	Operators and Organizational Direct Support and General Support Maintenance Manual: Landing Craft, Utility, Design LCU 1671 (NSN 1905-01-009-1056).
TM9-6140-200-12	Operator and Organizational Maintenance Manual for Lead Acid Storage Battery.
TM11-5820-401-12	(Sep 72) Operators and Organizational Maintenance Manual Including Repair Parts and Special Tools Lists: Radio Set AN-VRC-46 (NSN 5820-00-223-7433) and AN/VRC-47 (NSN 5820-223-7434).
TM11-5820-401-ESC-2	(May 75) Equipment Service Ability Criteria for Radio Set AN/VRC-46 (NSN 5820-00-223-7433).
TM11-5820-401-ESC-4	(May 75) Equipment Serviceability Criteria for Radio Set AN/VRC-47 (NSN 5820-00-223-7434).
TM11-5820-820-12	(Aug 74) Operator and Organizational Maintenance Manual Including Repair Parts and Special Tools List: Radio Set AN/URC-80(v)1 (NSN 5820-00-097-0082) Change 11.
TM11-5915-224-14	(Jan 73) Operators Organizational Direct Support and General Support Manual Including Repair Parts and Special Tools List. Suppressor, Electrical Transient MX7778/GRC. Changes 1 and 2. (NSN 5915-00-431-6718).
TM11-5915-224-24P	Organizational, Direct Support and General Support Repair Parts and Special Tools List Including Depot Maintenance Repair Parts and Special Tools. For Suppressor, Electrical Transient MX7778/GRC, (NSN 5915-00-431-6718).

**SECTION III. BASIC ISSUE ITEMS LIST-
REFERENCE PUBLICATIONS (CONTINUED).**

	DESCRIPTION
TM11-5820-640-15	(May 69) Operators, Organizational, Direct Support, General Support and Depot Maintenance Manual: Radio Set AN/URC 10, Changes 1 - 5.
TM11-5820-800-12	(Nov 73) Operators and Organizational Maintenance Manual Including Repair Parts and Special Tools List: Radio Set AN/PRC 90 NSN 5820-00-782-5308. Changes 1 and 2.
TM11-6125-252-15	(Jul 71) Operators, Organizational, DS, GS and Depot Maintenance Manual Including Repair Parts and Special Tools Lists: Motor-Generator PU-724/G.
TM55-501	(Sep 72) Marine Crewman's Handbook. Change 1.
TM55-503	(Jul 66) Marine Salvage and Hull Repair. Change 1.
TM55-509	(Mar 71) Marine Engineman's Handbook.
TM746-186	(May 76) Procedures for Rapid Deployment, Redeployment and Retrograde for Floating Equipment.
TB5-4200-200-10	(Apr 77) Hand Portable Fire Extinguishers Approved for Army Users.
TB55-1900-202-12/1	(Oct 64) U.S. Army Mobility Equipment Center Floating Craft: Preventive Maintenance.
TB55-1900-204-24	(Apr 74) ARC Welding on Water Borne Vessels.
TB55-1900-205-24	(Jan 77) Watercraft Information and Reporting System (WIRS) Data Collection for Configuration Control.
TB55-1900-206-14	(Jan 75) Control and Abatement of Pollution by Army Watercraft.
TB55-1900-207-24	(Jul 74) Treatment of Cooling Water in Marine Diesel Engines.

**APPENDIX C
SECTION III. BASIC ISSUE ITEMS LIST
(REFERENCE PUBLICATIONS - CONTINUED)**

	DESCRIPTION
TB-TC15-17	(Dec 75) In-Service Testing of Engine Lubricating Oil.
TB 43-0144	(Jun 74) Painting of Vessels.
LO 55-1905-220-12	Landing Craft, Utility, Marionette Marine Corporation. Hull Numbers 1671-1679 (NSN 1905-01-009-1056).
FM 55-90	(Oct 76) Army Water Transportation Operations.

Change 5 C-125

APPENDIX C
SECTION IV. BASIC ISSUE ITEMS LIST
Firefighting, Safety, and Damage Control Items

(1) ILLUS NUMBER	(2) NATIONAL STOCK NUMBER	(3) DESCRIPTION CAGEC and Part Number	Usable On Code	(4) U/I	(5) Qty rqr
	4210-00-209-5023	Adapter, 1-1/2" National Pipe Thread to 1-1/2" National Standard Thread		EA	2
	6840-01-315-9841	Bacteriostatic Additive, (Eye and Face Wash Fountain)		BX	1
		FIRE FIGHTERS ENSEMBLE			
	8460-00-606-8366	Bag, Fire Fighter Ensemble		EA	6
	8430-00-753-5935	Boots, Size 5		PR	6
	8430-00-753-5936	Boots, Size 6		PR	6
	8430-00-753-5937	Boots, Size 7		PR	6
	8430-00-753-5938	Boots, Size 8		PR	6
	8430-00-753-5939	Boots, Size 9		PR	6
	8430-00-753-5940	Boots, Size 10		PR	6
	8430-00-753-5941	Boots, Size 11		PR	6
	8430-00-753-5942	Boots, Size 12		PR	6
	8430-00-753-5943	Boots, Size 13		PR	6
	8430-00-753-5944	Boots, Size 14		PR	6
	8430-00-753-5945	Boots, Size 15		PR	6
	8415-01-300-6557	Coverall, Medium		EA	3
	8415-01-300-6558	Coverall, Large		EA	2
	8415-01-300-6559	Coverall, X-Large		EA	1
	8415-01-267-9661	Gloves, Anti-Rash		PR	6
	8415-01-335-7902	Gloves, Medium		PR	3
	8415-01-335-7903	Gloves, Large		PR	2
	8415-01-335-7904	Gloves, X-Large		PR	1
	8415-01-271-8069	Helmet		EA	6
	8415-01-268-3473	Hood, Anti-Flash		EA	6
	4220-00-276-8926	Buoyant Vest, Work Type		EA	6
	NA	Burn Dressing Kit, Contains two 8" X 18", one 4" X 16", four 4" X 4", one 12" X 16" (Face Mask) Dressings, and one Package of Burn-jel Topical Dressing, (No NSN, Local Purchase Item). Ordering Information: "Water-jel AWK Kit", H & H Associates Inc., P.O. Box 4469, Alexandria, VA 22303, Phone: 1-800-326-5708		KT	1
	4240-00-238-9959	Canister, Training		EA	2
	4240-01-159-1986	Canister, Training, Locker		EA	1

**APPENDIX C
SECTION IV. BASIC ISSUE ITEMS LIST
Firefighting, Safety, and Damage Control Items - CONT**

(1) ILLUS NUMBER	(2) NATIONAL STOCK NUMBER	(3) DESCRIPTION CAGEC and Part Number	Usable On Code	(4) U/I	(5) Qty rqr
	2720-00-227-7225	Duct, 8" Dia. X 15' Long, With Carrier		EA	2
	4240-01-116-9888	Emergency Escape Breathing Device (EEBD)		EA	22
	NA	Emergency Position Radio Beacon (EPIRB), Category 1, 406 MHz Satellite, FC.C. Approved (No NSN, Local Purchase Item)		EA	1
	4240-00-542-2048	Face Shield, Industrial, Tilting		EA	3
	4210-00-142-4949	Fire Ax		EA	6
	NA	Fire Blanket, 72" X 60", (No NSN, Local Purchase Item). Ordering Information: "Water-jel AWK Fire Blanket", H & H Associates Inc., P.O. Box 4469, Alexandria, VA 22303, Phone: 1 -800-326-5708		EA	1
	4210-00-889-2491	Fire Extinguisher, Portable, 10 lb., USCG Approved		EA	19
	4820-00-540-2381	Foot Valve with Strainer, 3" ID		EA	1
	4240-01-258-1245	Fountain, Eye and Face Wash, 16 Gal.		EA	1
	4240-00-190-6432	Goggle, Industrial, No Vents, (Chemical Flash)		EA	1
	4240-00-052-3776	Goggle, Safety, Vented, Clear		EA	15
	8415-00-935-3136	Hard-hat, Orange		EA	10
	8415-00-935-3139	Hard-hat, White		EA	5
	4240-00-022-2522	Harness, Safety, Torso		EA	6
	4240-00-540-0632	Helmet, Welder's		EA	1
	2040-00-268-9250	Hook, Boat		EA	2
	4210-00-776-0657	Hose, Exhaust, Engine, 2" ID X 20' Long		EA	1
	4210-01-131-0249	Hose, Fire, 1 1/2" X 50', Orange		EA	10
	4210-01-131-0247	Hose, Fire, 2 1/2" X 50', Orange		EA	4
	4210-01-248-8822	Hose, Potable Water, 1 1/2" X 50', Blue		EA	3
	4210-00-725-9234	Hose, Exhaust, Suction, 3" ID X 10' Long		EA	1
	NA	Hydrostatic Release Unit, Hammar H2O, Life-raft (No NSN, Local Purchase Item), Hammer H2O, MPN 6D887, Part Number HA2000H		EA	2
	8415-00-268-8264	Jacket, Welder's		EA	1
	6545-01-155-1598	Kit, Flotation Assembly, Includes two Flotation Tubes with Covers, five Restraint Straps, and one five pound Ballast Bar		KT	1

**APPENDIX C
SECTION IV. BASIC ISSUE ITEMS LIST
Firefighting, Safety, and Damage Control Items - CONT**

(1) ILLUS NUMBER	(2) NATIONAL STOCK NUMBER	(3) DESCRIPTION CAGEC and Part Number	Usable On Code	(4) U/I	(5) Qty rqr
	4730-00-542-3359	Kit, Pipe Repair, Emergency, P/N MIL-4-17882B (81349)		KT	1
	4240-00-022-2518	Lanyard, Safety Harness		EA	6
	4240-00-022-2521	Lanyard, Safety Harness, Dyna Brake		EA	4
	4010-00-285-9901	Life Line, OBA Tending		EA	2
	5510-00-260-8953	Plug, Soft Wood, 1" X 0" X 3" Long		EA	10
	5510-00-260-8958	Plug, Soft Wood, 2" X 0" X 4" Long		EA	10
	5510-00-260-8962	Plug, Soft Wood, 3" X 0" X 8" Long		EA	10
	5510-00-260-8969	Plug, Soft Wood, 7" X 3" X 10" Long		EA	10
	5510-00-260-8973	Plug, Soft Wood, 8" X 4" X 10" Long		EA	5
	5510-00-260-8949	Plug, Soft Wood, 10" X 7" X 12" Long		EA	5
	4220-00-275-3157	Ring Buoy, Life Saving, 30"		EA	8
	2090-00-052-1581	Shoring, Steel, Adjustable, Long, 6' to 11'		EA	5
	2090-00-058-3737	Shoring, Steel, Adjustable, Short, 3' to 5'		EA	5
	1670-01-226-5300	Sling, Rescue Helicopter Hoisting		EA	1
	9390-01-078-8660	Tape, Retro Reflective, 3" X 50 yds		RL	1
	9390-01-082-8927	Tape, Retro Reflective, 1" X 50 yds		RL	1
	4240-01-116-9889	Training Unit, EEED		EA	1
	5510-00-268-3479	Wedge, Plug, Tapered, Hardwood, 2" X 2" X 8" Long		EA	10
	5510-00-268-3485	Wedge, Plug, Tapered, Hardwood, 4" X 2" X 8" Long		EA	10
	5510-00-268-3481	Wedge, Plug, Tapered, Hardwood, 3" X 3" X 12" Long		EA	10
	5510-00-268-3475	Wedge, Shoring, Tapered, Hardwood, 1 1/2 X 2 X 12" Long		EA	10
	5510-00-268-3476	Wedge, Shoring, Tapered, Hardwood, 1 1/2 X 3" X 12" Long		EA	10
	5120-00-277-9075	Wrench, Spanner, Adj 1 1/2" to 3"		EA	10
	5120-00-277-9076	Wrench, Spanner, (P-250 Pump)		EA	10

APPENDIX C
SECTION V. BASIC ISSUE ITEMS LIST
COMMUNICATIONS, ELECTRONIC, NAVIGATION (CEN) COMMERCIAL
TECHNICAL MANUALS AND PUBLICATIONS

NUMBER	DESCRIPTION/TITLE
	Alden Electronics SATFIND-406 M3 EPIRB Owner's Manual
	Alden TR-IV Marinefax Technical Manual and Operator's Manual
Instruction Book No. 71261 Rev. C and Instruction Book Cat. No. 120 and 122 No. 509754	Belfort Instrument Company Aerovane Indicator Model 135
	Bendix/King EPH/EPI Series Portable Radio Owner's Manual
	Bendix/King EPH Series Portable Radio Service Manual
	Bendix/King LAA Series Battery Chargers Service Manual
	Dymek DA100D All Wave Receiving Antenna Owner Information Manual
	Mackay Communications 403A Emergency Lifeboat Transceiver Instruction Manual
	Naval Electronics Inc. MK22CA/Pba 2205 System Installation and Service Manual
	Newmar Heavy Duty DC-DC Converters Operation and Installation Instructions
RMC Document Number G261404 Rev A	Raytheon Marine Company Radar Set Model R40XIR41 X AN/SPS-69 Description, Operation and Maintenance Technical Manual
	Ross Engineering DSC 500 Digital Selective Call Marine VHF Transceiver Operating Manual
TM-8080000701	Sunair Electronics, Inc. Digital Automatic Antenna Coupler DCU-100 Operation and Maintenance Manual

Change 6 C-129/(C-130 blank)

**APPENDIX D
ADDITIONAL AUTHORIZATION LIST.**

SECTION I. INTRODUCTION.

D-1. SCOPE

This appendix lists additional items you are authorized for the support of the Landing Craft.

D-2. GENERAL

This list identifies items that do not have to accompany the Landing Craft and that do not have to be turned in with it. These items are all authorized to you by CTA, MTOE, TDA, or JTA.

D-3. EXPLANATION OF LISTING

National stock numbers, descriptions, and quantities are provided to help you identify and request the additional items you require to support this equipment. The items are listed in alphabetical sequence by item name under the type document (i.e., CTA, MTOE, TDA, or JTA) which authorizes the item(s) to you.

SECTION II.

ADDITIONAL AUTHORIZATION LIST.

(1) NATIONAL STOCK NUMBER	(2) DESCRIPTION FSCM & PART NUMBER	USABLE ON CODE	(3) U/M	(4) QTY AUTH
4210-00-684-3997	No Ref (33333) Adapter, Hose, 1 1/2 Female to 2 1/2 Male		ea	1
5120-00-293-0665	800E1337 (02413) Adapter, Hose, Swivel, Female 1 1/2 to 2 1/2		ea	1
6140-00-234-7360	3257A (81348) Bar, Wrecking, 30 inches		ea	6
7510-00-889-3494	75 (72583) Battery Filler, Jug Type		ea	1
7195-00-224-5190	B43064 (81349) Binder, Loose-leaf		ea	2
7195-00-224-5191	No Ref (33333) Board, Bulletin, Type A		ea	1
7330-00-078-5706	S3209-638101 (80064) Board, Bulletin, Type B		ea	1
7350-00-251-8746	LLL-B-568 (81348) Board, Food Chopping		ea	1
7330-00-241-8168	8051749061 (81349) Book Rack, Type C (Modified to 30 inches width)		ea	2
7125-00-132-8973	L-T-48 (81348) Bowl, Eating Plastic		ea	14
7125-00-132-8973	B-2054 (81348) Bowl, Mixing w/cover, 7 1/2 Qt.		ea	1
7125-00-132-8973	805-1636842 (80064) Cabinet, Filing, Stl, 4 Drawers w/Combination Lock		ea	1
7125-00-132-8973	S3209921643 (81348) Cabinet, Key, 75 Key		ea	1
5120-00-229-3054	GGG-C-105, Type 1 (81348) Caliper, Micrometer, 2-12 inch		ea	1
7105-00-663-5688	AA-C-291, Type 1, Class 2, (81348) Chair, Folding		ea	1
7110-00-273-8782	AA-C-275 (81348) Chair, Straight, W/Arms		ea	2
5110-00-554-7345	GG-C-313 Chisel, (81348) Cape, 6 3/4 in. x 1/4 in.		ea	2
5120-00-529-3744	GGG-C-406, Type 1, Class A (81348) Clamp, "C", Heavy		ea	2

**SECTION II. ADDITIONAL AUTHORIZATION LIST.
(CONTINUED).**

(1) NATIONAL STOCK NUMBER	(2) DESCRIPTION	(3) USABLE ON CODE	(4) U/M	(4) QTY AUTH
5940-00-195-9689	PP-10921 (80249) Clip, Elcl, Crocodile, 3 1/4 inches Long		ea	4
	MIL-C-1194 (81348) Clock, Mechanical, 12 hr. Battery Oper		ea	6
	CH2V-M (14718) Coffee Maker, 2 Burner Electric Plate 12 OV AC		ea	1
4310-01-085-2032	FM10 (11568) Compressor, Air, Portable, Electric Motor Driven		ea	1
5110-00-188-2524	GGG-C-740 (81348) Cutter, Bolt, 36 inches Long		ea	1
5110-00-293-0460	GGG-C-171, Type 1, Class A Cutter, Pipe 1/8 inch - 2 inches		ea	1
5110-00-541-1644	GGG-T-330 (81348) Cutting & Flaring Set, Tubing		ea	1
4510-00-585-6305	WW-P-541 (81348) Dispenser, Paper Towel		ea	1
	SK-1 IMP (12864) Dispenser, Milk, 5 Gallon Refrigerated		ea	1
	No Ref (33333) Flag Bag, Portable, Aluminum, 20 Gage 27 1/2 x13 x 26, Hinged, 72 Compartments 3 x 3 1/2 x 13, w/Lock & Handles		ea	1
7340-00-223-7791	U-10815, Type 1, Size 1 (81348) Fork, Cooks, Food Preparation 15 inches Long, 2 tines		ea	1
	DDP12N (19177) Fountain, Drinking, Size 10		ea	1
7240-00-527-9868	RR-F-800 (81 48) Funnel, Steel, W/Strainer, 1 Qt		ea	2
5120-00-892-5485	GG-M-86, Type 1, Class 1 Hammer, Carpenter 1 Lb		ea	1
5120-00-243-2957	GGG-H-86 (81348) Hammer, Hand, Scaling, 1 Lb		ea	4
5120-00-243-2957	GGG-H-86 (81348) Hammer, Sledge, 10 Lb		ea	1

**SECTION II. ADDITIONAL AUTHORIZATION LIST.
(CONTINUED).**

(1) NATIONAL STOCK NUMBER	(2) DESCRIPTION	(3)	(4) QTY AUTH	
	FSCM & PART NUMBER	USABLE ON CODE	U/M	
7920-00-246-0930	NN-H-101, Type II, Class 1 (81348) Handle, Mop, 54 inches Long		ea	3
	MIL-S-23566 (81348) Heater, Immersion, Elcl, 2 inches IPS Vertical 1.2 & 1.0 KW, 120V AC		ea	1
3940-00-937-7978	115R (93601) Hoist, Lever/Ratchet, 1000 Lb Cap		ea	2
4720-00-288-8532	ZZ-H-001 (81348) Hose, Assembly, (Fresh Water Fill) 1 1/2 x 50 feet		ea	2
	CG3264 (75324) Kit, Service, Line Throwing Device		ea	1
	MS17114-1 SYM 229 (96906) Light, Berth		ea	14
6210-00-153-6668	MIL-STD-16719 Light, Desk, Chart Table (W/Filter Assembly MIL-STD-16721)		ea	1
	S3605-630718 (80064) Locker, Cleaning Gear, Aluminum		ea	1
	805-1363771 (80064) Locker, Fuse, Aluminum 15 x 11 3/8		ea	1
	805-1360106 & 805-1360107 (80064) Locker, Hand Grenade, Aluminum, 26 1/8 x 13 15/16		ea	1
	805-1629989 (80064) Locker, Life Jacket		ea	1
2090-00-368-4792	No Ref 33333 Locker, Medical First Aid Box		ea	2
	No Ref 33333 Locker, OBA Storage, Type A		ea	2
	805-1360275 (80064) Locker, Pyrotechnic		ea	1
2090-00-243-2362	S3209860212 (80064) Locker, Safe, No. 7		ea	1
	805-1626432 (80064) Locker, Type B-1, Aluminum, 3 high, 12 openings		ea	4
	805-1400-952 (80064) Locker, Type K		ea	1

**SECTION II. ADDITIONAL AUTHORIZATION LIST.
(CONTINUED).**

(1) NATIONAL STOCK NUMBER	(2) DESCRIPTION FSCM & PART NUMBER	(3) USABLE ON CODE	(4) U/M	(4) QTY AUTH
4930-00-253-2478	S3605 860080 (80064) Locker, Wash Deck Gear G-38590 (81349) Lubricating Gun, Hand, 16 Oz		ea ea	1 3
5120-00-221-2731	M-15926, Type 1 (81348) Marline spike, 8 inches 4M-155 (crane co.) Mirror, w/shelf 2 pc combination, plate glass		ea ea	2 4
4930-00-266-9182	805-1636410 (80064) Modular Group 14 805-1637731 (80064) Modular Group 8 GGG-0-591 (81348) Oiler, Hand, 8 Oz.		ea ea	1 3
7330-00-272-2590 5340-00-582-2742 7330-00-205-3164	FF-0-591 (81348) Opener, Can, Elcl, PTbl NS35647-1 (96906) Padlock, Keyed RR-P-54, Type 1 (81348) Pan. Baking & Roasting, 13 1/4 x 9 1/4 x 2 1/4		ea ea ea	1 60 1
7330-00-205-3150 7210-00-268-8675	RR-P-62 (81348) Pan, Cake, Round, 9 x 11 3/8 V-P-356 (81348) Pillow, Bed		bx ea	1 14
7210-00-231-2373 7330-00-205-4146 7330-00-263-8505	DDD-P-351 (81348) Pillowcase, Bed RR-B-500 (81348) Pot, Cooking, w/Cover, 14 qt. RR-B-500 (81348) Pot, Cooking, no Cover, 24 qt.		ea ea ea	28 1 1
5120-00-243-2776 5120-00-595-9304	WW-P-796 (81348) Puller, Fuse, #3 GGG-P-781 (81348) Puller, Mechanical, Gear 0-6 inch		ea ea	4 1
5110-00-449-7313	HP (45225) Punch Set, Gasket Cutting		ea	1
7240-00-965-4427	HR200 (78790) Range, Elcl, Type B, 12 KW, 440V L-W-25 (81348) Receptacle, Waste, w/Cover, 10 Gallon		ea ea	1 1

SECTION II. ADDITIONAL AUTHORIZATION LIST.
(CONTINUED).

(1) NATIONAL STOCK NUMBER	(2) DESCRIPTION FSCM & PART NUMBER	USABLE ON CODE	(3) U/M	(4) QTY AUTH
7240-00-857-2277	L-W-25, Class A, Size 4 (81348) Receptacle, Waste w/cover, 24 Gallon		ea	2
7510-00-161-6215	MLH-10-1OAD-U (89729) Refrigerator/Freezer GG-R-791 (81348) Ruler, Wood, 12 inches		ea ea	2 1
7520-00-162-6178	F-S-58 (81348) Sharpener, Pencil		ea	5
5110-00-161-6909	GGG-S-278 (81348) Shears, General Purpose		ea	3
	S3209-921650 (80064) No Ref (33333) Shelf, Plastic Top, Writing, Hinged, Steel		ea	1
3439-00-930-1638	450 (11103) Soldering Gun, Elcl, Trigger Opr.		ea	1
7240-00-177-6154	S-1285 (81349) Spout, Flexible		ea	5
7250-00-298-7043	RR-S-714 (81348) Stencil Set, Mrkg. 1" Letters		ea	1
7110-00-634-8596	AA-S-700 (81348) Stool, Wood, Revolving		ea	1
7310-00-224-9192	IBB4 (78770) Toaster, Elcl, Automatic, 4 Slice, 115 V, 60 Hz, Single Phase		ea	4
3439-00-542-0531	GGG-T-570 (81348) Torch Kit, Soldering L.P Gas		ea	1
7350-00-195-7334	T-46D (81349) Tray, Mess, Cres, 6 Compartments		ea	14
7350-00-823-7301	T-43259 (81349) Tray, Service		dz	1
7430-00-254-4321	No Ref (33333) Typewriter, Office Non-portable		ea	1
5120-00-221-1117	GGG-V-410 (81348) Vise, Machinist, 5 inch Jaw		ea	1
5120-00-288-6518	GGG-V-415 (81348) Vise, Pipe		ea	1
	LC2 (23671) Washer/Dryer, 110/115 V AC, White		ea	1
6605-00-273-6985	S-3717 (81348) Weight, Sounding, 7 Lb		ea	1
5120-00-293-0317	GGG-W-651, Type II, Class A (81348) Wrench, Pipe, Adjustable, 24 inches		ea	1

APPENDIX D

SECTION II. ADDITIONAL AUTHORIZATION LIST

(CONTINUED)

(1) ILLUS NUMBER	(2) NATIONAL STOCK NUMBER	(3) DESCRIPTION FSCM and Part Number	Usable On Code	(4) U/M	(5) Qty rqr
	5120-00-935-7333	OEXM709 (00770) Wrench Set, Combination Box and Open End, Metric		EA	1
	5130-00-081-2308	GGG-W-614 (81348) Wrench Set, Socket, 3/4 inch Drive		EA	1
	5120-00-132-0399	VM-820 (95021) Wrench Set, Socket Insert (For converting standard socket to metric sizes)		SE	1
	7910-00-530-0260	MIL-C-52074A, Type 1 (81349) Cleaner, Vacuum, Industrial Type, 120 V, 400 Hz		EA	1
		23-7245 (05083) Alarm, Gas, Oxygen With Probe		EA	1
		GE-V8(27020) Blower, Ventilating, Portable		EA	1
		160 016/2/2 (01752) Lamp, Flame Safety		EA	1
	4220-00-020-0538	MIL-L-18045 (81349) * Life Preserver, Vest (for Passengers)		EA	AR
	1005-00-879-2819	2663138 (53711) Gun Mount		EA	4
		5184210 (53711) Ammo Locker		EA	1
		*Order only amount needed for amount of passengers to be carried.			

APPENDIX E

EXPENDABLE SUPPLIES AND MATERIALS LIST.

SECTION I. INTRODUCTION.

E-1. SCOPE

This appendix lists expendable supplies and materials you will need to operate and maintain the Landing Craft. These items are authorized to you CTA 50-970, Expendable Items (Except Medical, Class V, Repair Parts, and Heraldic Items).

E-2. EXPLANATION OF COLUMNS

a. Column 1 - Item number.

b. Column 2 - Level. This column identifies the lowest level of maintenance that requires the listed item.

C - Operator/Crew

F - Direct Support Maintenance

H - General Support Maintenance

c. Column 3 - National Stock Number. This is the National stock number assigned to the item; use it to request or requisition the item.

d. Column 4 - Description. Indicates the Federal item name and, if required, a description to identify the item. The last line, for each item indicates the Federal Supply Code for Manufacturer (FSCM) in parentheses followed by the part number.

e. Column 5 - Unit of Measure (U/M). Indicates the measure used in performing the actual maintenance function. This measure is expressed by a two-character, alphabetical abbreviation (e.g., ea, in, pr). If the unit of measure differs from the unit of issue, requisition the lowest unit of issue that will satisfy your requirements.

SECTION II. EXPENDABLE SUPPLIES AND MATERIALS LIST

(1) ITEM	(2) LEVEL	(3) NATIONAL STOCK NUMBER	(4) DESCRIPTION	(5) U/M
1	C	6810-00-249-9354	Acid, Sulfuric (Electrolyte) O-S-801 (81348)	8 gal
2	C		Antifreeze, Arctic Solution No Ref (33333) MIL-A-11755 (81349)	AR
3	C	6850-00-181-7929	Antifreeze, Ethylene Glycol, Inhibited, Heavy Duty 1 Gal Can MIL-A-46153 (81349)	AR
4	C	6850-00-181-7933	Antifreeze, Ethylene Glycol, Inhibited, Heavy Duty 5 Gal Can MIL-A-46153 (81349)	AR
5	C	6850-00-181-7940	Antifreeze, Ethylene Glycol, Inhibited, Heavy MIL-A-46153 (81349) 55 Gal Drum	AR
6	C	7520-00-281-5911	Basket, Waste Paper RR-B-181 (81349)	5ea
7	C	6135-00-050-3280	Battery, Dry Cell, 6V BA200U (81350)	24 ea
8	C	6140-00-057-2553	Battery, Dry Storage, 12V U/O Portable Megaphone MS35000-1 (96906)	1 ea
9	C	6135-00-050-3280	Battery, Emergency Light BA-200U (81350)	6 ea
10	C	6135-00-120-1020	Battery, Flashlight, BA-30 (80063) (24 Box)	4 bx
11	C	6140-00-234-7360	Battery, Filler, Jug Type 75 (72583)	1 ea
12	C	3940-00-239-8769	Block, Tackle, Fr., 6 inches	2 ea
13	C	3940-00-068-9173	Block, Tackle, Fr., 8 inches	2 ea
14	C	7330-00-078-5706	Board, Food Chopping LL-B-563 (81348)	2 ea
15	C	6830-00-729-4377	Bottle, Freon 12, BB-F-421 (81348)	1 ea
16	C	7350-00-251-8746	Bowl, Eating, Plastic L-T-48 (81348)	14 ea
17	C	7330-00-685-5013	Bowl Set, Food Mixing RR-B-1242 (81348)	1 ea
18	C	7330-00-262-2323	Bowl, Mixing, 5qt MIL-B-2054 (81349)	1 ea

SECTION II. EXPENDABLE SUPPLIES AND MATERIALS LIST (CONTINUED).

(1) ITEM	(2) LEVEL	(3) NATIONAL STOCK NUMBER	(4) DESCRIPTION	(5) U/M
19	C	7920-20-291-8305	* Broom, Push, Rattan (no handle) H-B-71 (81348)	2 ea
20	C	7920-00-291-8305	Broom, Upright, Corn H-B-51 (81348)	5 ea
21	C	7920-00-240-6358	Brush, Dusting, Bakery, H-B-190 (81348)	6 ea
22	C	7920-00-243-3407	* Brush, Floor Sweeping, 18 inches (no handle) H-B-651 (81348) * Handles are provided at time of vessel activation.	2 ea
23	C	7920-00-772-5800	Brush, Sanitary H-B-481 (81348)	2 ea
24	C	7920-00-240-7171	* Brush, Scrub, SQ End Deck (no handle) H-B-531 (81348)	4 ea
25	C	7920-00-240-7174	Brush, Scrub, Flr Hand H-B-1490 (81348)	2 ea
26	C	7920-00-291-5815	Brush, Wire, Curved Handle H-B-178, Type II, Class 1 (81348)	4 ea
27	C	7920-00-246-8501	Brush, Wire, 7 1/2 inch	2 ea
28	C	5130-00-293-0263	Brush, Wire, Rotary Wheel, 1/2 in. Arbor H-B-771, Type III, Class L (81348)	2 ea
29	C	7330-00-550-7592	Butchers Steel, 10 inches long	1 ea
30	C	7240-00-256-7700	Can, Flam. Waste, 10 Gal RR-C-114 (81348)	2 ea
31	C	7240-00-178-8288	Can, Gas, 5 Gal RR-S-30, Style 2 (81348)	2 ea
32	C	5120-00-529-4124	Carrier, Storage Battery, Size 20, MIL-C-19482 (81349)	1 ea
33	C	5940-00-195-9689	Clip, Elcl Crocodile, 3 1/2 in. Long PP-10921 (80249)	4 ea
34	C	7520-00-240-5503	Clipboard, File LLL-A-00650 (81348)	3 ea
35	C	8030-00-307-8630	Compound Anti-sieze MIL-T-83483 (81349) (pipe joint & thread)	2 lb

SECTION II. EXPENDABLE SUPPLIES AND MATERIALS LIST (CONTINUED).

(1) ITEM NUMBER	(2) LEVEL	(3) NATIONAL STOCK NUMBER	(4) DESCRIPTION	(5) U/M
36	C	7930-00-880-4454	Compound, Dishwashing, Hand Liquid P-D-410 (81348)	5 ea
37	C	4020-00-240-2164	Cord, Cotton 1/4 inch 200 ft. coil	1 coil
38	C	4020-00-240-2160	Cord, Cotton, 5/16 inch, 1200 ft. coil T-C-571 (81348)	1 coil
39	C	7350-00-935-6635	Crust, Condiment, 6 oz., DD-T-101 (81348)	3 ea
40	C	7350-00-823-7563	Cup, Drinking, Glass, 10 1/2 oz DD-T-90 (81348)	14 ea
41	C	7350-00-823-7394	Cup, Drinking, Glass, 6 1/2 oz DD-T-90 (81349)	14 ea
42	C	7350-00-223-7760	Cup, Drinking, Plastic 10 oz L-T-48, Class 2 (81348)	14 ea
43	C	7230-00-849-9839	Curtain, Shower, 48 x 72 in. L-C-780 (81348)	4 ea
44	C	7330-00-633-8904	Cutter, Doughnut, Stl, 3 inch MIL-C-40115 (81349)	2 ea
45	C	6830-00-584-3041	Cylinder, Replacement, Propane EB-G-110 (81348)	2 ea
46	C	7330-00-373-2488	Dipper, Kitchen, 1/2 qt. RR-D-400 (81348)	1 ea
47	C	7350-00-823-7398	Dish, Sauce, 5 9/16 in. Dia DD-T-90 (81348)	14 ea
48	C	5345-00-881-8378	Disk, Abrasive, #24 PD-455, Type 1, Class 1 (81348)	6 ea
49	C	5345-00-581-8377	Disk, Abrasive, #36 PD-455, Type 1, Class 1 (81348)	6 ea
50	C	5345-00-881-8375	Disk, Abrasive, #60 PD-455, Type 1, Class 1 (81348)	6 ea
51	C	7330-00-190-5190	Dish Pan, Rd, 10 qt, RR-D-450 (81348)	1 ea

SECTION II. EXPENDABLE SUPPLIES AND MATERIALS LIST (CONTINUED).

(1) ITEM	(2) LEVEL	(3) NATIONAL STOCK NUMBER	(4) DESCRIPTION	(5) U/M
52	C	7350-00-205-0928	Dispenser, Napkin RR-D-500 (81348)	3 ea
53	C	7350-00-641-6050	Dispenser, Sugar, 12 pz. DD-T-101 (81348)	3 ea
54	C	7330-00-305-3154	Double Boiler, Cooking, 3 qt. RR-B-500, Style A (81348)	1 ea
55	C	7330-00-984-4065	Double Boiler, Cooking, 5 1/2 qt RR-B-500 Style B (81348)	1 ea
56	C	7290-00-224-8308	Dustpan, RR-D-800 (81348)	7 ea
57	C	7330-00-243-3408	Egg Beater, RR-E-300, Type 1 (81348)	1 ea
58	C	7330-00-815-1458	Egg Whip, RR-W-456, Size 3 (81348)	1 ea
59	C	8345-00-935-0445	Flag, Signal, "A" Intn'l Code, 512E6 MIL-F-2692	1 ea
60	C	8345-00-926-6803	Flag, Signal, "B" Intn'l Code, Size 6 MIL-F-2692 (81349)	1 ea
61	C	8345-00-935-0446	Flag, Signal, "C" Intn'l Code, Size 6 MIL-F-2692 (81349)	1 ea
62	C	8345-00-926-6805	Flag, Signal, "D" Intn'l Code, Size 6 MIL-F-2692 (81349)	2 ea
63	C	8345-00-935-0447	Flag, Signal, "E" Intn'l Code, Size 6 MIL-F-2692 (81349)	1 ea
64	C	8345-00-926-9218	Flag, Signal, "F" Intn'l Code, Size 6 MIL-F-2692 (81349)	1 ea
65	C	8345-00-926-9987	Flag, Signal, "G" Intn'l Code, Size 6 MIL-F-2692 (81349)	1 ea
66	C	8345-00-935-0448	Flag, Signal, "H" Intn'l Code, Size 6 MIL-F-2692 (81349)	1 ea
67	C	8345-00-935-0449	Flag, Signal, "I" Intn'l Code, Size 6 MIL-F-2692 (81349)	1 ea
68	C	8345-00-026-6810	Flag, Signal, "J" Intn'l Code, Size 6 MIL-F-2692 (81349)	1 ea

SECTION II. EXPENDABLE SUPPLIES AND MATERIALS LIST (CONTINUED).

(1) ITEM	(2) LEVEL	(3) NATIONAL STOCK NUMBER	(4) DESCRIPTION	(5) U/M
69	C	8345-00-926-9988	Flag, Signal, "K" Intn'l Code, Size 6 MIL-F-2692 (81349)	1 ea
70	C	8345-00-935-0450	Flag, Signal, "L" Intn'l Code, Size 6 MIL-F-2692 (81349)	1 ea
71	C	8345-00-935-0444	Flag, Signal, "M" Intn'l Code, Size 6 MIL-F-2692 (81349)	1 ea
72	C	8345-00-926-0001	Flag, Signal, "N" Intn'l Code, Size 6 MIL-F-2692 (81349)	1 ea
73	C	8345-00-935-0451	Flag, Signal, "O" Intn'l Code, Size 6 MIL-F-2692 (81349)	1 ea
74	C	8345-00-935-0452	Flag, Signal, "P" Intn'l Code, Size 6 MIL-F-2692 (81349)	1 ea
75	C	8345-00-935-0453	Flag, Signal, "Q" Intn'l Code, Size 6 MIL-F-2692 (81349)	1 ea
76	C	8345-00-926-6812	Flag, Signal, "R" Intn'l Code, Size 6 MIL-F-2692 (81349)	1 ea
77	C	8345-00-933-0454	Flag, Signal, "S" Intn'l Code, Size 6 MIL-F-2692 (81349)	1 ea
78	C	8345-00-926-6002	Flag, Signal, "T" Intn'l Code, Size 6 MIL-F-2692 (81349)	1 ea
79	C	8345-00-926-6814	Flag, Signal, "U" Intn'l Code, Size 6	1 ea
80	C	8345-00-935-0955	Flag, Signal, "V" Intn'l Code, Size 6 MIL-F-2692 (81349)	1 ea
81	C	8345-00-935-0456	Flag, Signal, "W" Intn'l Code, Size 6 MIL-F-2692 (81349)	1 ea
82	C	8345-00-926-6004	Flag, Signal, "X" Intn'l Code, Size 6 MIL-F-2692 (81349)	1 ea
83	C	8345-00-935-0457	Flag, Signal, "Y" Intn'l Code, Size 6 MIL-F-2692 (81349)	1 ea

SECTION II. EXPENDABLE SUPPLIES AND MATERIALS LIST (CONTINUED).

(1) ITEM	(2) LEVEL	(3) NATIONAL STOCK NUMBER	(4) DESCRIPTION	(5) U/M
84	C	8345-00-935-0458	Flag, Signal, "Z" Intn'l Code, Size 6 MIL-F-2692 (81349)	1 ea
85	C		Food Turner MIL-U-10815, Class B (81349)	2 ea
86	C	7340-00-240-7077	Fork, Cook's, 14 in. GGG-C-746, Type II (81348)	2 ea
87	C	7340-00-241-8169	Fork, Table RR-F-150 (81348)	2 ea
88	C	6230-00-264-8261	Flashlight, Watertight, 2 cell, MIL-F-3746 (81349)	5 ea
89	C	9140-00-286-5283	Fuel, Diesel, Bulk, Df-A Arctic No Ref (33333)	70 bl
90	C	9140-00-286-5286	Fuel, Diesel, Bulk, DF/Winter No Ref (33333)	70 bl
91	C	9140-00-286-5294	Fuel, Diesel, Bulk, DF2 Regular No Ref (33333)	70 bl
92	C	7240-00-233-4482	Funnel, Steel, W/Strainer, D gallon RR-F-800 Type 1, Class B (81348)	2 ea
93	C	7240-00-527-9868	Funnel, Steel, W/Strainer, 1 qt RR-F-800, Type 1, Class B (81348)	2 ea
94	C	7240-00-404-9793	Funnel, Plastic, 1 qt. L-F-1593 (81348)	1 ea
95	C	4930-00-287-5419	Gun, Fluid, Dir. Del. GGG-0-591 (81348)	1 ea
96	C	4930-00-253-2478	Gun, Grease, Hand, 14 oz. Cap MIL-C-3359C (81349)	1 ea
97	C	9150-00-190-0900	Grease, Auto & Artillery, 5 lb Can MIL-C-10924 Symbol GAA	5 lb
98	C	9150-00-663-9795	Grease, Ball & Roller Bearing, BR 5 lb. Can, MIL-G-18709 (81349)	6 ea
99	C	9150-00-530-6814	Grease, Wire Rope, Exposed, 35 lb. Pail No. Ref (33333) MIL-G-18458/Ships	2 ea

SECTION II. EXPENDABLE SUPPLIES AND MATERIALS LIST (CONTINUED).

(1) ITEM	(2) LEVEL	(3) NATIONAL STOCK NUMBER	(4) DESCRIPTION	(5) U/M
100	C	4020-00-240-2161	Halyard, Cotton, Braided, 1/4 inch MIL-H-226, Class 1 (81349)	1 Cl
101	C	7920-00-263-0328	Handle, Wood, Acme Thread NN-B-104, Class 1, Type 1 (81348) Brush, Floor Sweeping	2 ea
102	C	7920-00-141-5452	Handle, Wood NN-H-5154, Type 1, Class 2 (81348)	2 ea
103	C	7230-00-252-3394	Hook, Shower Curtain No Ref (33333)	18 Bx
104	C	9150-00-252-0293	Hydraulic Fluid, Automatic Transmission (5 Gal Can) 5GM2C41A (00501)	2 Cn
105	C	4730-00-470-6625	Kit, Fitting, Copper Tubing 51025 (30320)	1 ea
106	C	7340-00-223-7771	Knife, Cook's 12 inch GGG-C-746 (81348)	1 ea
107	C	7340-00-223-7769	Knife, Paring, 3 1/2 inches GGG-C-746 (81348)	1 ea
108	C	7340-00-223-7766	Knife, Slicing, 12 in. GGG-C-746 (81348)	1 ea
109	C	7340-00-543-7004	Knife, Meat, Table Kings Pattern (31121)	1 ea
110	C	7340-00-291-0625	Knife, Steak, 10 in. GGG-C-746 (81348)	1 ea
111	C	7340-00-241-8170	Knife, Table 10 inch RR-F-450 (81348)	1 Bx
112	C	7330-00-254-4793	Ladle, Kitchen 2 oz. RR-L-30 (81348)	3 ea
113	C	7330-00-248-1153	Ladle, Kitchen 8 oz. RR-L-30 (81348)	2 ea
114	C	6220-00-299-7146	Lens, Marine, Navigational	1 ea
115	C	6220-00-299-7151	Lens, Marine, Navigational	1 ea
116	C	7330-00-170-8342	Liner, Baking Cup MIL-L-40610 (81349)	1 ea
117	C	4020-00-240-2185	Marline, Hemp T-R-605, Type 4, Class 1, 20 lb. coil (81348)	1 Cl
118	C	7330-00-205-3093	Masher, Potato, Hand RR-W-456 (81348)	1 ea

SECTION II. EXPENDABLE SUPPLIES AND MATERIALS LIST (CONTINUED).

(1) ITEM	(2) LEVEL	(3) NATIONAL STOCK NUMBER	(4) DESCRIPTION	(5) U/M
119	C	7240-00-233-6025	Measure, Liquid, 1 Gal, RR-M-1850, Type 1, Class A (81348)	3 ea
120	C	7240-00-233-6013	Measure, Liquid, 1 qt. RR-M-190, Type 1, Class B (81348)	3 ea
121	C	7330-00-272-7876	Meas. Set, 4 spoon, MIL-M-40122 (81349)	1 ea
122	C	8465-00-238-3344	Megaphone, Hand, 18 in. M-1263 (81348)	1 ea
123	C	7920-00-171-1148	Mophead, Wet, T-M-561, Type 1, Style 1 (81348)	3 ea
124	C	8540-00-285-7001	Napkin, Table, Paper No Ref (33333)	1 ea
125	C	9150-00-117-8791	Oil Lubrication (for 2 cycle engine) 2 pts per 6 gallons of gasoline	2 Cn
126	C	9150-00-257-5440	Oil, Lubrication, GOS (5 gal. can) MIL-L-10324 (81349)	5 ea
127	C	9150-00-264-3941	Oil, Lubricating, PE-10 (5 gal can) No Ref (33333)	5 ea
128	C	9140-00-405-2987	Oil, Lubricating, Gear G090, 5 gal Can No ref (33333)	5 gl
129	C	9150-00-577-5844	Oil, Lubrication, Gear OE/HDO 40 (185 GL required) No ref (33333)	5 gl
130	C	9150-00-598-2911	Oil, Lubrication, Refrigerant Compressor, 1 qt can VV-L-825 (81348)	10 ea
131	C	9140-00-491-7197	Oil, Lubrication, Sub Zero OE/HDO-10 (185 GL required) EMERY3908D (33358)	18 ea
132	C	7240-00-160-0455	Pail, Utility, Metal, 3 1/2 gal RR-P-30 (81348)	7 ea
133	C	7330-00-634-4464	Pan, Baking Roasting, RR-P-94, Size 5 (81348)	2 ea
134	C	7330-00-255-5995	Pan, Bread, 10 3/8 inches long	2 ea

SECTION II. EXPENDABLE SUPPLIES AND MATERIALS LIST

(1) ITEM	(2) LEVEL	(3) NATIONAL STOCK NUMBER	(4) DESCRIPTION	(5) U/M
135	C	7330-00-246-2402	Pan, Fry, 6 3/4 inches RR-P-89, Size 1, (81348)	1 ea
136	C	7330-00-238-3805	Pan, Fry, 12 inches RR-P-89, Size 2 (81348)	1 ea
137	C	7330-00-244-4549	Pan, Muffin, 12 Cup RR-P-54 (81348)	2 ea
138	C	7330-00-823-6883	Pan, Pie, Alum, 9 inches RR-P-54, Type V (81348)	2 ea
139	C	6665-00-050-8529	Paper, Chemical Agent Determination	6 ea
140	C	8540-00-530-3769	Paper, Toilet UU-P-556 (81348)	1bx
141	C	7330-00-238-8316	Peeler, Potato MIL-P-20583 (81349)	2 ea
142	C	6850-00-090-1361	Paste, Water Indicator No Ref (33333)	2 ea
143	C	8345-00-935-0401	Signal "1" Numerical, Intn'l Code, Size 6 Pennant, MIL-P-2692 (81349)	1 ea
144	C	8345-00-935-0495	Pennant, Signal, "0" Numerical Intn'l Code Size 6 MIL-F-2692 (81349)	1 ea
145	C	8340-00-926-6023	Pennant, Signal, "2" Numerical Intn'l Code Size 6 MIL-F-2692 (81349)	1 ea
146	C	8345-00-935-0490	Pennant, Signal, "3" Numerical Intn'l Code Size 6 MIL-F-2692 (81349)	1 ea
147	C	8345-00-935-0491	Pennant, Signal, "4" Numerical Intn'l Code Size 6 MIL-F-2692 (81349)	1 ea
148	C	8345-00-935-0492	Pennant, Signal, "5" Numerical Intn'l Code Size 6 MIL-F-2692 (81349)	1 ea
149	C	8345-00-935-0493	Pennant, Signal, "6" Numerical Intn'l Code Size 6 MIL-F-2692 (81349)	1 ea
150	C	8345-00-026-9214	Pennant, Signal, "7" Numerical Intn'l Code Size 6 MIL-F-2692 (81349)	1 ea

SECTION II. EXPENDABLE SUPPLIES AND MATERIALS LIST (CONTINUED).

(1) ITEM	(2) LEVEL	(3) NATIONAL STOCK NUMBER	(4) DESCRIPTION	(5) U/M
151	C	8345-00-935-0494	Pennant, Signal, "8" Numerical Intn'l Code Size 6 MIL-F-2692 (81349)	1 ea
152	C	8345-00-935-0405	Pennant, Signal, "9" Numerical Intn'l Code Size 6 MIL-F-2692 (81349)	1 ea
153	C	8345-00-935-0410	Pennant, Signal Answering MIL-F-2692 (81349)	1 ea
154	C	8345-00-926-5900	Pennant, Signal Answering, 1st Repeater, Intn'l Code Size 6 MIL-F-2692 (81349)	1 ea
155	C	8345-00-935-0421	Pennant, Signal Answering, 2nd Repeater, Intn'l Code Size 6 MIL-F-2692 (81349)	1 ea
156	C	8345-00-925-9207	Pennant, Signal Answering, 3rd Repeater, Intn'l Code Size 6 MIL-F-2692 (81349)	1 ea
157	C	7350-00-195-4763	Pitcher, Syrup, 20 pt. DD-T-101, Type 1, (81348)	3 ea
158	C	7350-00-249-5165	Pitcher, Water, Square RR-P-386, Size 2 (81348)	3 ea
159	C	7930-00-266-7137	Polish, Metal, Type 2, Class 1, PP-536 (81348)	1 bx
160	C	7330-00-775-3941	Pot, Cooking, W/Cover, 9 qt. MIL-P-40686 (81349)	2 ea
161	C	7330-00-240-2134	Saucepan, W/Cover, 1 qt. MIL-S-40044, Size 1 (81349)	2 ea
162	C	7330-00-240-2137	Saucepan, W/Cover, 7 qt. MIL-P-40044	2 ea
163	C	7330-00-153-9760	Scoop, Kitchen, RR-S-121 (81348)	1 ea
164	C	4020-00-240-2015	Seizing Stuff, Hemp 1/4 inch	1 cl
165	C	7350-00-240-7068	Shaker, Pepper, 9 cu in. cap, RR-K-260 (81348)	1 ea
166	C	7350-00-240-7069	Shaker, Salt, 9 cu in. cap, RR-K-260 (81348)	1 ea

SECTION II. EXPENDABLE SUPPLIES AND MATERIALS LIST (CONTINUED).

(1) ITEM	(2) LEVEL	(3) NATIONAL STOCK NUMBER	(4) DESCRIPTION	(5) U/M
167	C	7350-00-680-2630	Shaker, Salt or Pepper, 2 oz DD-T-101 (81348)	6 ea
168	C	7330-00-793-7356	Sharpener, Knife, Wall Mounted, RR-S-310 (81348)	1 ea
169	C	7330-00-184-0089	Sheet Plastic, (Food Wrap), L-P-370 (81348)	6 ea
170	C	7330-00-184-0089	Sifter, Flour, RR-S-345 (81348)	1 ea
171	C	7930-00-664-0337	Soap, Laundry, 100 lb. Drum, P-S-1792, Type 2, Class 2 (81348)	1 dr
172	C	3439-00-188-6986	Solder, Lead Alloy, Acid Core, QQ-S-771 (81349)	1 dr
173	C	3439-00-188-6988	Solder, Lead Alloy, Rosin Core, QQ-S-571-(81349)	1 sl
174	C	7330-00-684-8740	Spatula, Steel, 14 inches long, GGG-C-746 (81348)	1 ea
175	C	7340-00-223-7800	Spoon, Basting, 21 inches long, MIL-U-10815 (81349)	1 ea
176	C	7340-00-241-8171	Spoon, Dessert, 7 inches long, RR-F-617 (81348)	1 bx
177	C	7340-00-240-7080	Spoon, Food Service, 15 inches long, RR-S-617 (81348)	2 ea
178	C	7340-00-599-8357	Spoon, Iced Tea, RR-F-450 (81348)	1 bx
179	C	7340-00-205-1421	Slotted Spoon, Servicing, 15 inches long, RR-F-617 (81348)	3 ea
180	C	7340-00-205-3341	Spoon, Table, CRES R-F-450 (81348)	1 bx
181	C	7340-00-205-3340	Teaspoon, CRES RR-F-455 (81348)	1 bx
182	C	6685-00-641-0189	Thermometer, Self-Indicating, Meat, GG-T-353 (81348)	1 ea
183	C	6685-00-255-9981	Thermometer, Self-Indicating, Oven GG-T-351 (81348)	1 ea

SECTION II. EXPENDABLE SUPPLIES AND MATERIALS LIST (CONTINUED).

(1) ITEM	(2) LEVEL	(3) NATIONAL STOCK NUMBER	(4) DESCRIPTION	(5) U/M
184	C	7330-00-616-0997	Tongs, Food Serving, MIL-T-40097, 12 inches long (81349)	4 ea
185	C	8540-00-291-0392	Towels, Paper, UU-T-591 (81348)	1 ea
186	C	7920-00-823-9773	Towel, Paper, Machinery, Wiping, UU-T-595, Type VI (81348)	1 ea
187	C	7350-00-680-6545	Tumbler, Drinking, Plastic, 8 oz. L-T-800 (81348)	2 doz
188	C	7920-00-579-8484	Wringer & Bucket, Mop, RR-M-1075 (81348)	4 ea
189	C	6850-00-753-4967	Inhibitor, Corrosion Preventive, 8 1/2 oz, O-I-490 (81348)	48 cn
190	C	8415-00-634-4658	Gloves, Leather, Welder's, JJ-C-451 (81348)	2 pr
191	C	5110-00-203-6424	Chisel, Power Hammer, GGG-C-330, Type XV, Class A (81348)	2 ea
192	C	8010-00-239-5737	Lead, White (Paste in oil) TT-W-251, Type B (81348)	1 Cn
193	C	7520-00-298-7044	Stencil Set, Marking, 2 inch RR-S-714 (81348)	1 ea
194	C	7520-00-272-9683	Stencil Set, Marking, 3 inch RR-S-714 (81348)	1 ea
195	C	5640-00-409-4265	Tape, Duct No Ref (33333)	6 ro
196	C	9905-00-182-5043	Tape, Reflector, Green, 6 x 3 inches No Ref (33333)	100 ro
197	C	4720-00-277-4029	Tubing, Copper, 1/4 inch MIL-T-2410 (81349)	1 cl
198	C	4720-00-277-4030	Tubing, Copper, 5/16 inch MIL-T-24107 (81349)	1 cl
199	C	4720-00-277-4027	Tubing, Copper, 3/8 inch MIL-T-24107 (81349)	1 cl
E-13				

SECTION II. EXPENDABLE SUPPLIES AND MATERIALS LIST (CONTINUED).

(1) ITEM	(2) LEVEL	(3) NATIONAL STOCK NUMBER	(4) DESCRIPTION	(5) U/M
200	C	4720-00-277-4026	Tubing, Copper, 1/2 inch MIL-T-24107 (81349)	1 cl
201	C	5330-00-641-1193	Asbestos Sheet, Compressed, 1/16 inch HH-P-466 (81348)	2 ea
202	C	5330-00-171-6551	Asbestos Sheet, Compressed, 1/8 inch HH-P-466 (81348)	2 ea
203	C	5330-00-641-3051	Rubber Sheet, Solid 1/16 inch MIL-G-1149, Type 1 Class 1 (81349)	10 ft
204	C	5330-00-729-5103	Rubber Sheet, Solid 1/8 inch MIL-G-1149, Type 1 Class 1 (81349)	10 ft
205	C	5330-00-729-5103	Packing 406-04825 (71724)	24 ft
206	C	9515-00-237-1865	Steel Sheet, Carbon	1 sh
207	C	5330-00-244-9276	Rubber Sheet	1 sy
208	C	5330-00-244-9279	Rubber Sheet	1 sy
209	C	5330-00-270-8466	Gasket Paper .006 thick	1 sy
210	C	5330-00-270-8468	Gasket Paper 1/64 inch thick	1 sy
211	C	5330-00-270-8470	Gasket Material, Paper	1 sy
212	C	5330-00-585-9502	Asbestos Sheet	6 sh
213	C	5970-00-905-8762	Insulation Sheets electrical	1 sh
214	C	4240-00-285-9901	Lifeline (3/16 inch x 50 feet long for use w/Breathing Apparatus	3 ea
215	C	8030-00-829-4554	Compound, Thread Locking	2 bt
216	C	6630-00-316-5831	Test Kit, Diesel Engine, Water	1 ea
217	C	4210-00-752-9343	Dry Chemical (Firefighting)	1 pl
218	C	8405-00-266-8691	Gloves, Rubber, Electricians	1 pr

SECTION II. EXPENDABLE SUPPLIES AND MATERIALS LIST (CONTINUED).

(1) ITEM NUMBER	(2) LEVEL	(3) NATIONAL STOCK NUMBER	(4) DESCRIPTION	(5) U/M
219	C		Compound P/N 5198563 (72582)	1 cn
220	C	8080-00-231-2345	Compound, Corrosion Preventative, MIL-C-16731	1 gl
221	C		Lamp, Fluorescent, 8w, P-1 (85213)	ea
222	C	6240-00-866-4143	Lamp, Incandescent, MS16524-2 (96906)	ea
223	C	6240-00-330-0139	Lamp, Incandescent, 12V 3022 (70623)	ea
224	C	6240-00-143-3119	Lamp, Incandescent, 60W, E-L-101 (81348)	ea
225	C	6240-00-143-3124	Lamp, Incandescent, 100w, W-L-101 (81348)	ea
226	C		Launcher, Rocket, Line Throwing Device, P/N CG3563 (75324)	ea
227	C		Line, Service, Line Throwing Device, P/N CG3575 (75324)	ea
228	C	8540-00-965-4691	Napkin, Table, Paper No Ref (33333)	bx
229	C	9150-00-985-7234	Oil, Lubricating, General Purpose, Mineral Oil (2135TH)	ga
230	C	9150-00-985-7237	Oil, Lubricating, General Purpose, Mineral Oil (2110TH)	gl
231	C	7930-00-295-0442	Powder, Scouring, P-S-311, (81348)	cn
232	C		Rocket, Buoyant, Line Throwing Device, P/N CG3562 (75324)	ea
233	C		Rocket, Standard, Line Throwing Device, P/N CG3561 (752324)	ea
234	C	4020-00-270-8763	Rope, Manila, 5/8 inch, T-R-605, Type H, Class 2	ft
235	C	4020-00-231-9014	Rope, Manila, 3 inches, TT-R-605, Type M, Class 2	cl
E-15				

SECTION II. EXPENDABLE SUPPLIES AND MATERIALS LIST (CONTINUED).

(1) ITEM	(2) LEVEL	(3) NATIONAL STOCK NUMBER	(4) DESCRIPTION	(5) U/M
236	C	4020-00-231-2568	Rope, Manila, 6 inches	cl
237	C	4020-00-752-8879	Rope, Nylon, Mooring, 4:, Each is to 50' long and has 41,300 lbs. breaking strength. MIL-R-17343	cl
238	C	6850-00-274-5421	Solvent, Cleaning, P/N P-D-680 (81348)	5 gls

☆ U.S. GOVERNMENT PRINTING OFFICE: 1991 554-123/20251

PIN: 057585-001

Change 1 E-16

**SECTION II.
EXPENDABLE SUPPLIES AND MATERIALS LIST (CONTINUED)
PUBLICATIONS.**

TB 5-4200-200-10	Hand Portable Fire Extinguishers Approved For Army Users	1
TB 43-0144	Painting of Vessels	1
TB 55-1900-202-12/1	US Army Mobility Equipment Center Floating Craft Preventive Maintenance	1
TB 55-1900-207-24	Treatment of Cooling Water in Marine Diesel Engines	1
TM 11-5820-401-10	Operator's Manual, Radio Sets AN/VRC-12, AV/VRC 43, 44, 45, 46, 47, 48 and 49	1
TM 11-5820-520-12	Operator & Organizational Manual, Radio Sets AN/GRC-106 & 106A	1
TM 11-5820-765-12	Operator & Organizational Manual, Power Supply, PP-4763/GRC, PP-4763A/GRC	1
TM 11-5841-268-25	Organizational (Field) Intermediate DS/GS & Depot Maintenance, Control, Transponder Set, C-6280(p)/APX, C-6280A/APX, C-6717/APX, C-7843/APX, C-6280A/(P)APX	1
TM 11-5895-490-20	Organizational Maintenance Manual, RCVR/Transmitter - Radio, RT-859/APX-72 & Mountings MT-3809/APX-72 And MT-3948/APX-72	1
TM 11-6130-233-12	Operator & Organizational Maintenance Manual, Incl Repair Parts Power Supplies PP-2953C/U, Changes 2-4	1
TM 55-506	Marine Electrical & Refrigeration Equipment	1
TM 55-509	Marine Engineers' Handbook	1
TM 55-1905-219-20P	Operator, Organizational Maintenance Repair Parts & Special Tools List, Landing Craft, Utility, Design LCU 1671, NSN 1905-01-009-1056	1
US Coast Guard	Oil Record Book For Non-Tankers	1
Form CG4602 DA Form 55-40	Deck Department Log	1
DA Form 55-44	Engine Department Log	1
TM 75-244-3	Procedures for Destruction of Equipment to Prevent Enemy Use	1
TBTC 15-17	Interservice Testing of Engine Lubricating Oil	1

**SECTION II.
EXPENDABLE SUPPLIES AND MATERIALS LIST (CONTINUED).
PUBLICATIONS (CONTINUED).**

7610-00-297-1545	Book, Medical	1
7610-00-263-9707	Book, American Practical Navigator	1
7610-00-680-0395	Book, Nautical Almanac	1
7610-00-227-1801	Book Set, Navigation Ships Medicine Chest & First Aid at Sea (US Public Health Service)	1
NAVSEA 0924-LP-038-1010	<p style="text-align: center;">Technical Manual For MK27, MOD 1 Gyro Compass</p> <p style="text-align: center;">LUBE ORDERS</p> <p style="text-align: center;">Will be disseminated when developed.</p>	1

**APPENDIX F
MANUFACTURED TOOLS.**

This appendix includes complete instructions for making items authorized to be manufactured or fabricated at Organizational Maintenance level.

A part number index in alphanumerical order is provided for cross-referencing the part number of the item to be manufactured to the figure which covers fabrication criteria.

All bulk materials needed for manufacture of an item are listed by part number or specification number in a tabular list on the illustration.

<u>TOOL PART NUMBER</u>	<u>FIGURE</u>
T8059	F-1
T6984	F-2
T9802	F-3
T6995	F-4
T6991	F-5
T9803	F-6
T10468-1	F-7
T10468-2	F-8
T6987	F-9

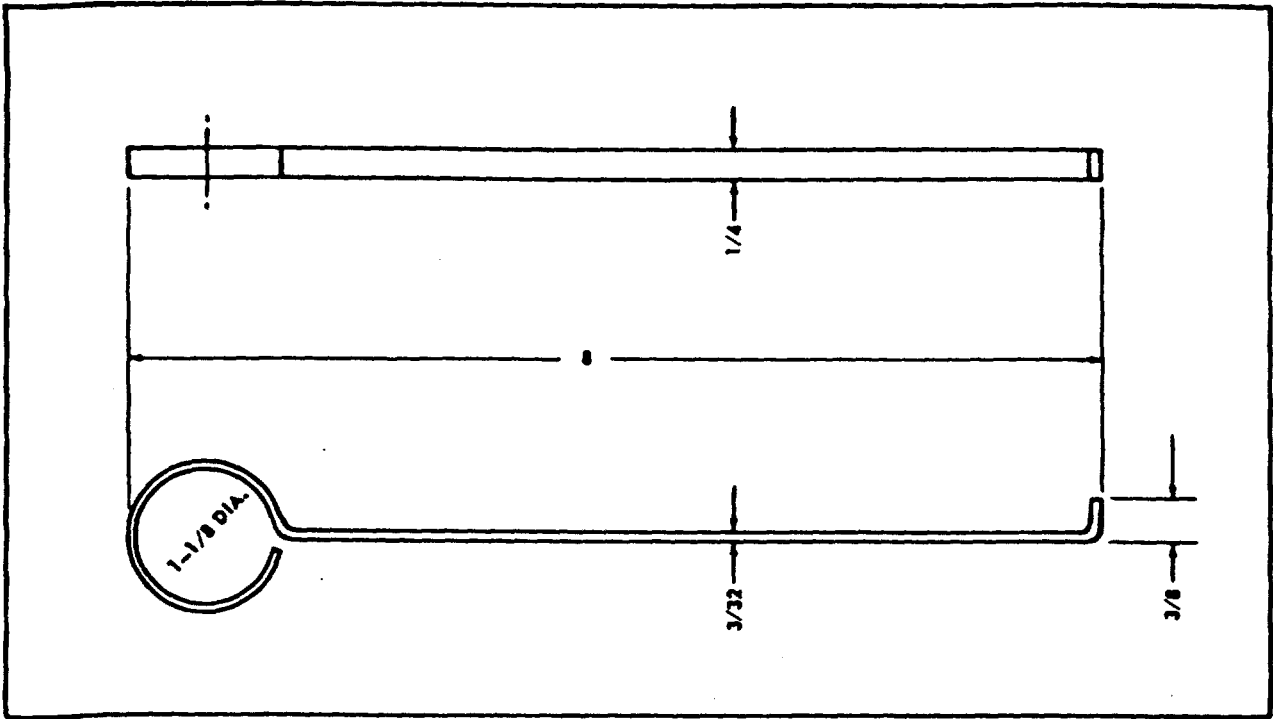

Figure F-1. Special Tool T-8059.

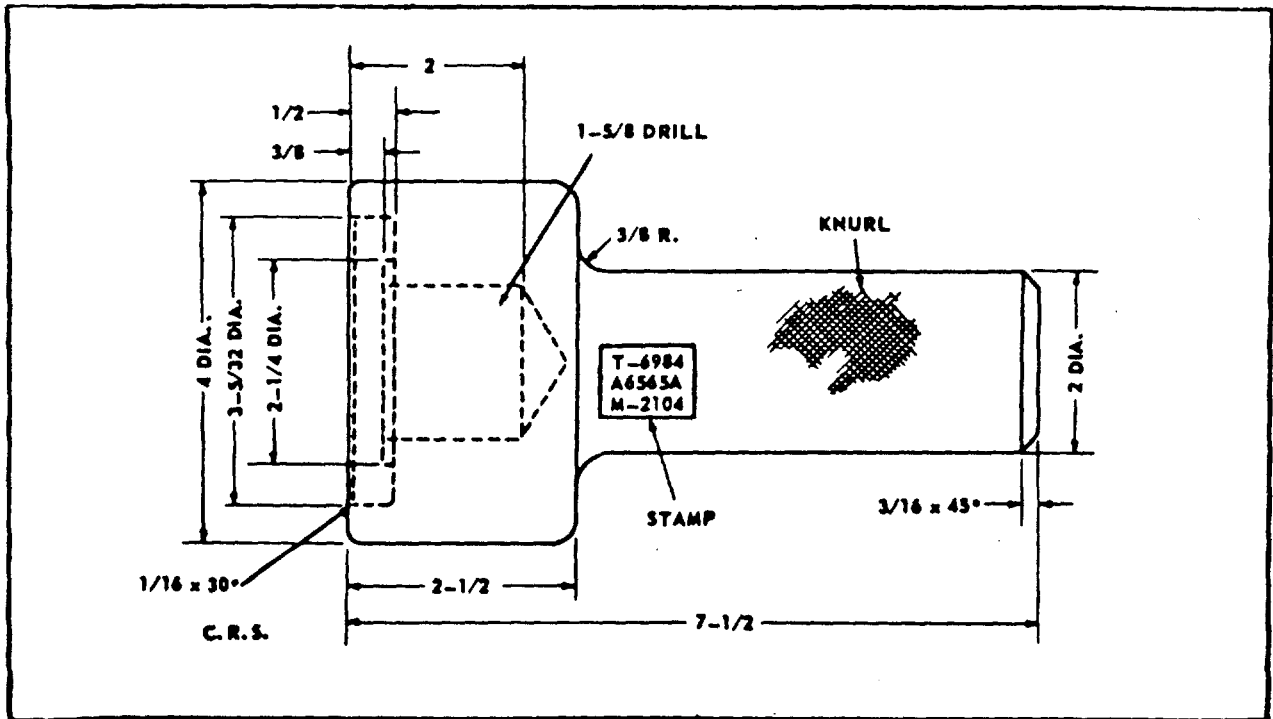

Figure F-2. Special Tool T-6984.

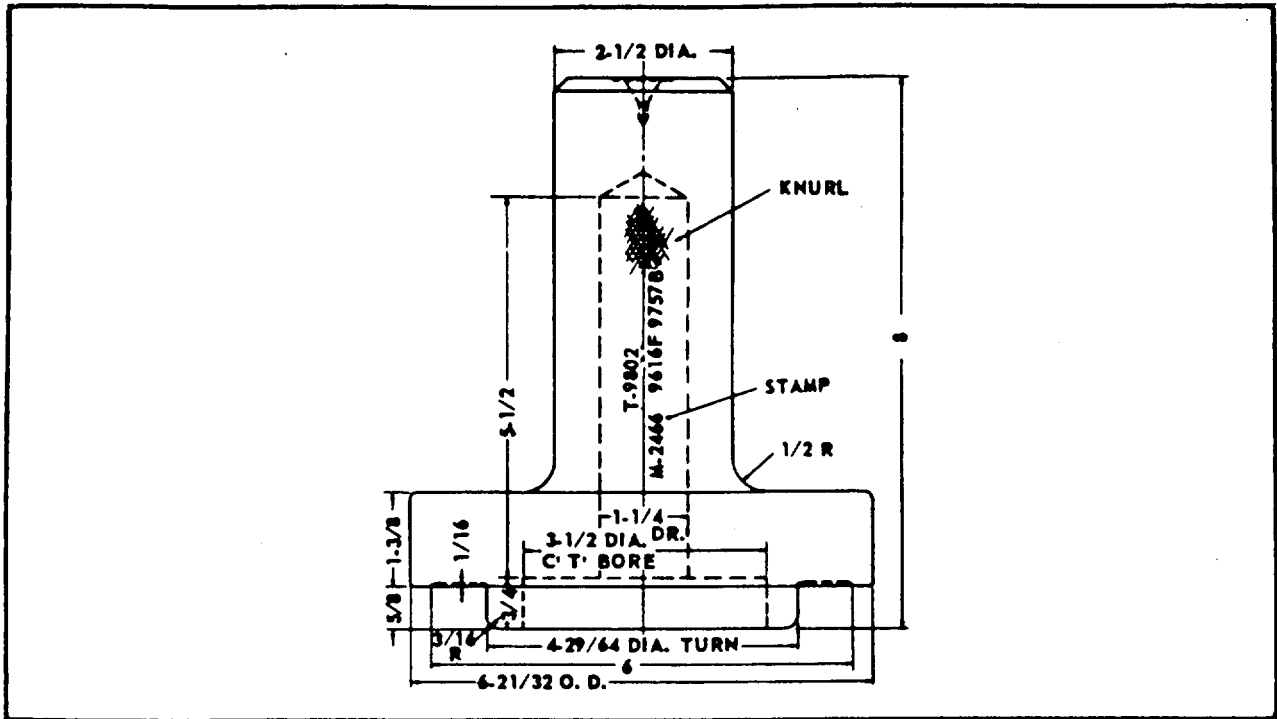

Figure F-3. Special Tool T-9802.

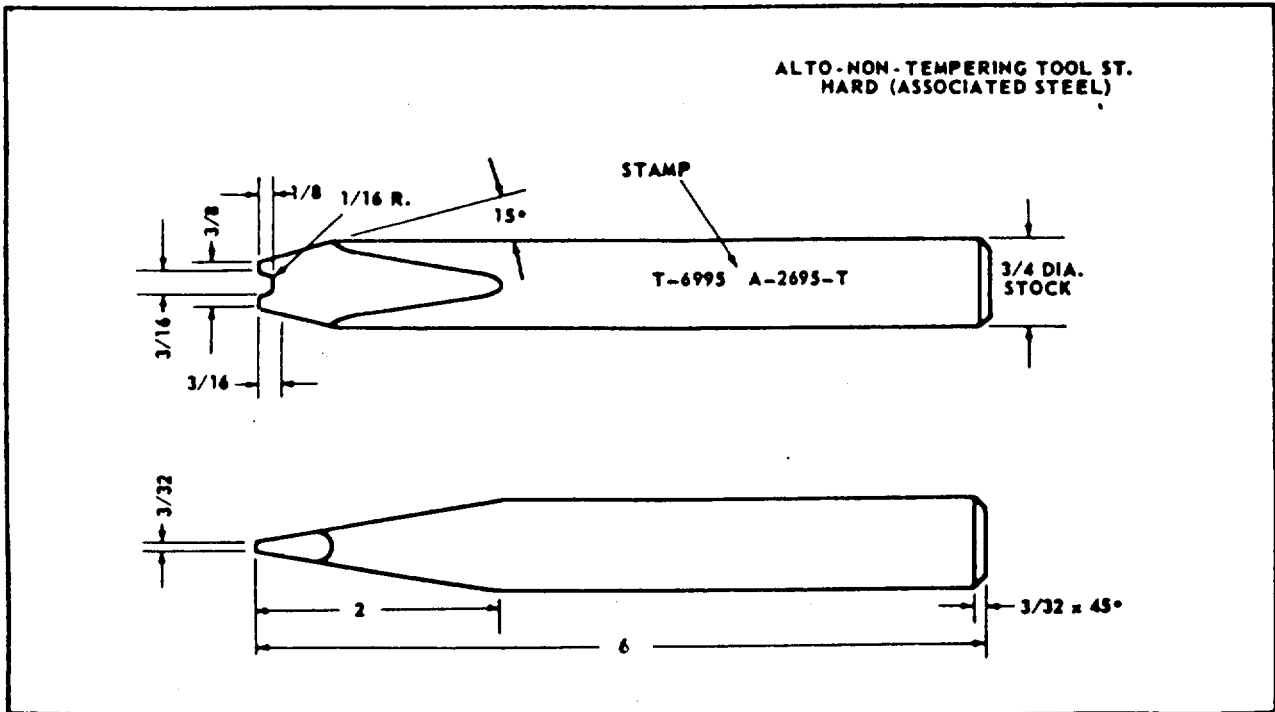

Figure F-4. Special Tool T-6995.

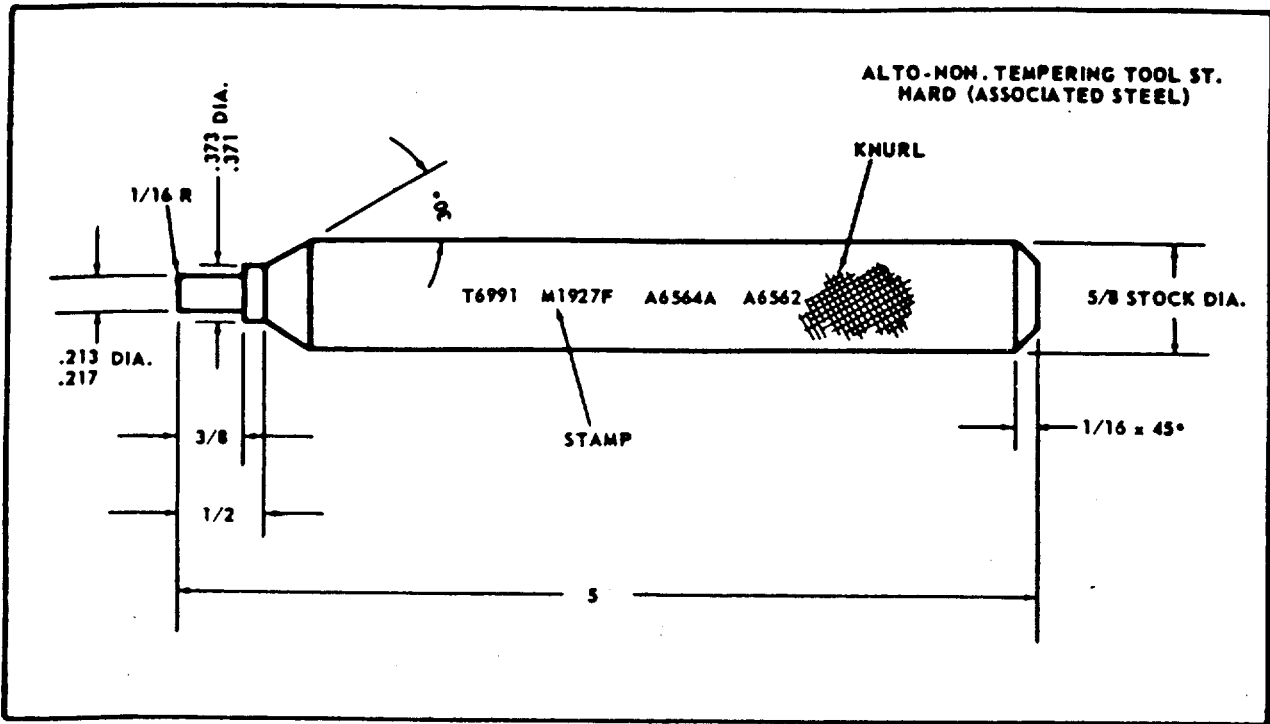

Figure F-5. Special Tool T-6991.

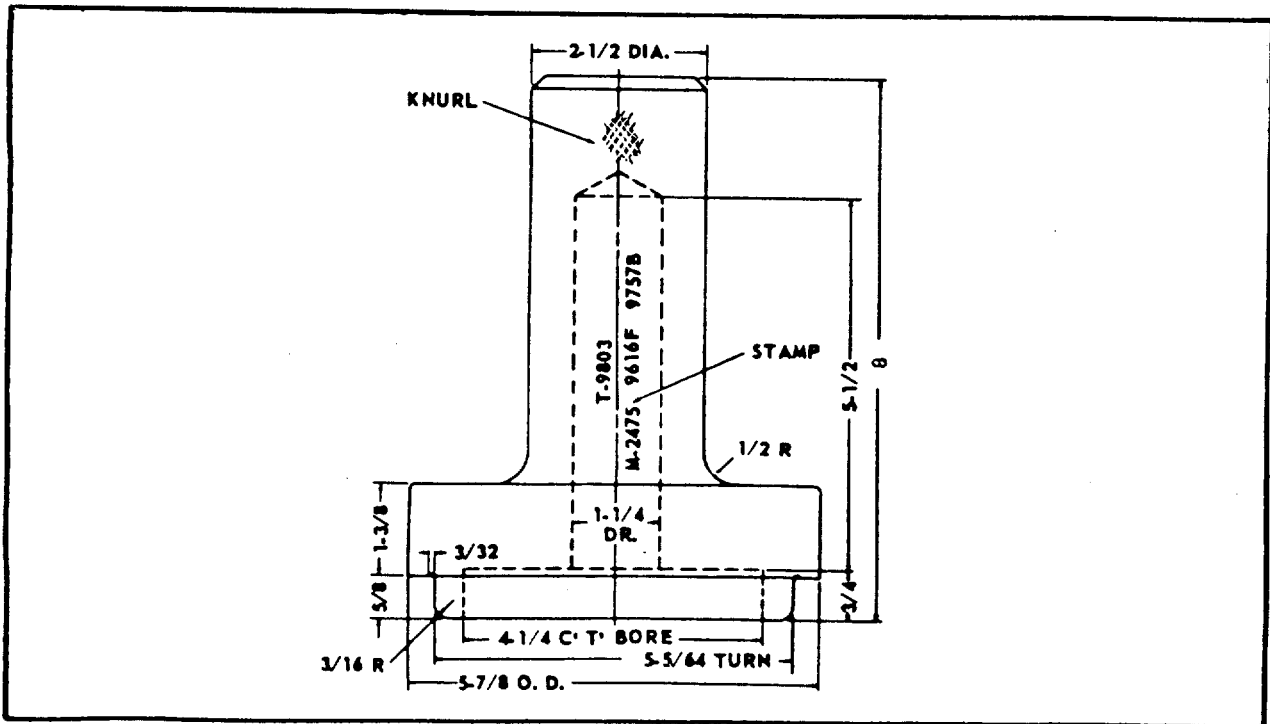

Figure F-6. Special Tool T-9803.

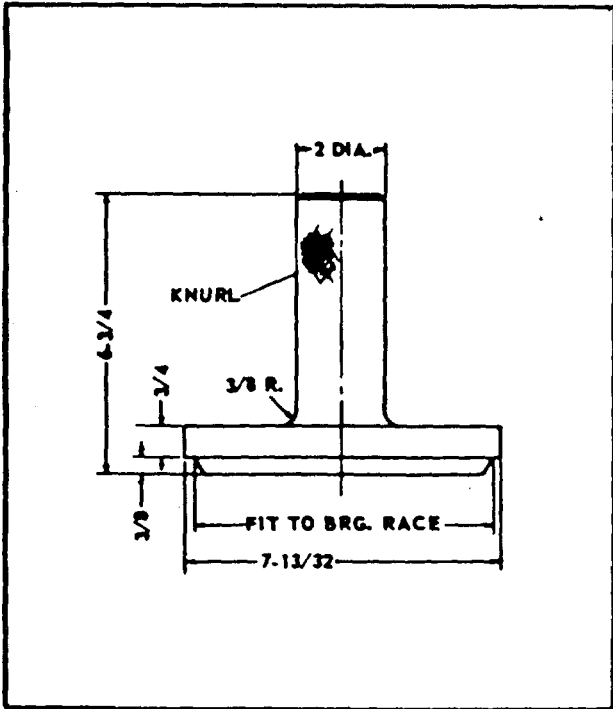

Figure F-7. Special Tool T-10468-1

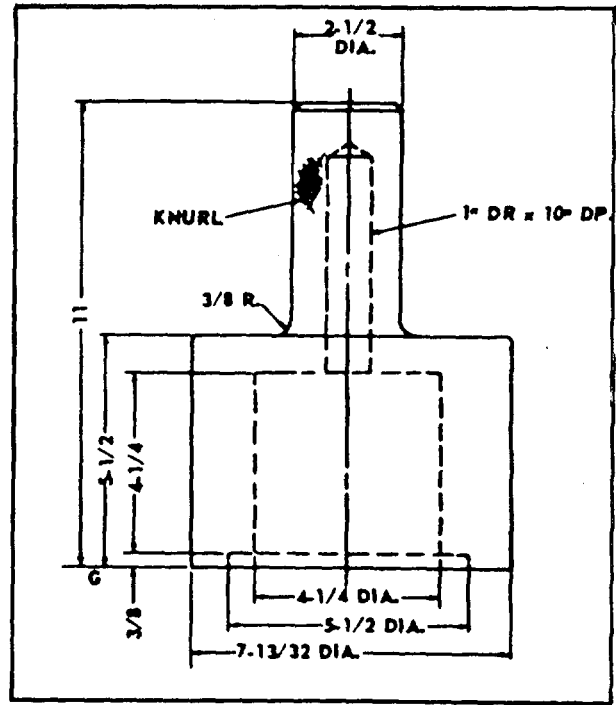

Figure F-8. Special Tool T-10468-2

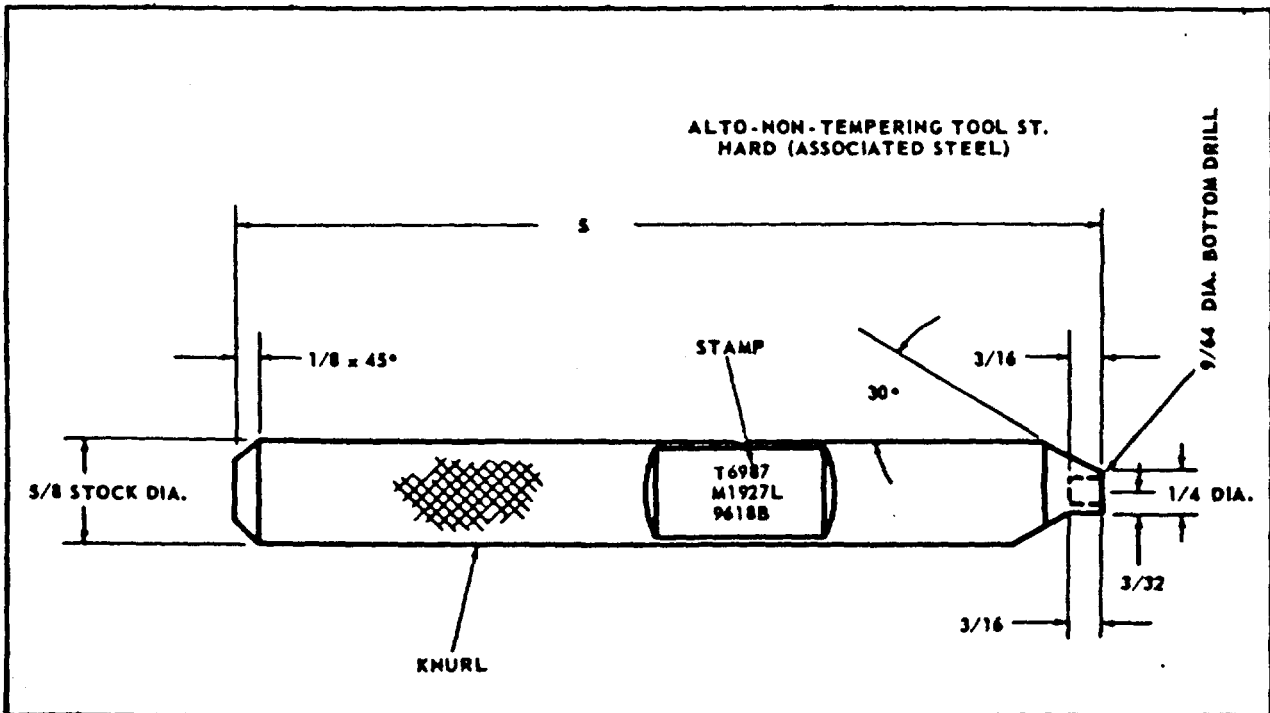

Figure F-9. Special Tool T-6987.

F-5/(F-6 Blank)

INDEX

HOW TO USE THE INDEX

The index is in alphabetic sequence and refers to volume, chapter, paragraph or table as follows:

CONTENTS

- Volume
 - 1 - Introduction and Operating Instructions
 - 2 - Operation Under Usual/Unusual Conditions
 - 3 - Operator Maintenance Instructions - Troubleshooting
 - 4 - Operator/Crew - Propulsion Engine and Marine Gear Maintenance Instructions
 - 5 - Operator/Crew - Electric Power Generation and Distribution Maintenance Instructions
 - 6 - Operator/Crew - Bow Ramp and Anchor Handling System Maintenance Instructions
 - 7 - Operator/Crew - Mast, Centralized Hydraulic System, Steering System, and Anchor Handling System Maintenance Instructions
 - 8 - Operator Maintenance Instructions for Auxiliary Equipment
 - 9 - Operator Maintenance Instructions for Auxiliary Equipment
 - 10 - Direct Support Maintenance Instructions
 - 11 - Direct Support and General Support Maintenance Instructions

- Chapter
 - 1 - Introduction
 - 2 - Operating Instructions
 - 3 - Operator/Organizational Maintenance - Propulsion Engine and Marine Gear, Generating System, Bow Ramp, Anchor Handling System, Central Hydraulic and Steering Systems
 - 4 - Operator/Organizational Maintenance - Auxiliary Equipment
 - 5 - Direct Support Maintenance Instructions
 - 6 - General Support Maintenance Instructions

For Example:

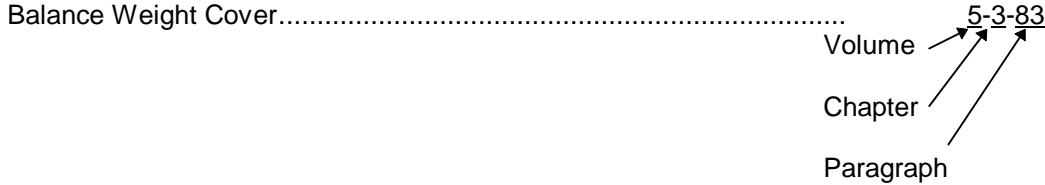

INDEX (Continued)

Volume - Chapter
- Paragraph
or Table

A

"A" Frame Hydraulic Winch.....	3-T3-83
"A" Frame - Principles of Operation	1-1-57
"A" Frame, Wire Rope and Anchor	7-3-182
Abbreviations - List of	1-1-6
Abnormal Engine Coolant Operating Temperature - Anchor Winch Engine.....	3-T3-66
Abnormal Engine Coolant Operating Temperature - Generator	3-T3-29
Abnormal Engine Coolant Operating Temperature - Propulsion	3-T3-8
Abnormal Engine Operation - Anchor Winch Engine.....	3-T3-61
Abnormal Engine Operation - Generator.....	3-T3-24
Abnormal Engine Operation Propulsion	3-T3-3
Accumulator - Anchor Winch	7-3-177
Accumulator - Generator	5-3-102
Accumulator - Propulsion.....	4-3-47
Accumulator	10-5-22
Administrative Storage	7-3-221
Aft Engine Room - Controls and Indicators	1-2-12
- Interior Arrangement.....	1-1-32
Air Cleaner - Anchor Winch	6-3-156
Air Cleaner - Generator	5-3-81
Air Conditioner System	8-4-29
Compressor	8-4-30
Condenser	8-4-31
Dryer.....	8-4-33
Gage Board.....	8-4-34
Strainer	8-4-32
Air Conditioner Water Circulating Pump	8-4-12
Air Conditioner Water Pump Motor Controller	8-4-12.4
Air Conditioner Water Pump Motor.....	8-4-12.3
Air Conditioner Water Pump	8-4-12.2
Air Conditioner Water Pump Set	8-4-12.1
Air Conditioning Machinery Room - Controls and Indicators	1-2-7
Air Conditioning Machinery Room - Interior Arrangement	1-1-28
Air Conditioning System	2-2-109
Circulating Fans.....	2-2-111
Sea Water Cooling Pump.....	2-2-110
System Shut-down	2-2-113
System Start-up	2-2-112

INDEX (Continued)

Volume - Chapter
- Paragraph
or Table

A (Continued)

Air Conditioning Water Circulation Pump Controller.....	11-5-128
Air Conditioning Water Circulation Pump Motor.....	11-5-127
Aircraft Flood Lights.....	2-2-166
Air Horn Assembly.....	4-3-57.1
Air Horn Air Compressor System	2-738.5.4-1498.7
Air Compressor.....	2-738.5.4-1498.7
Air Horn Air Compressor Hoses, Fitting and Piping	4-1498.1
Air Horn Operation	2-738.6
Air Horn Compressor Assembly.....	9-4-73.1
Air Intake - Anchor Winch.....	6-3-143
Air Intake - Propulsion	4-3-11
Air Intake Housing.....	4-3-11.2
Air Silencers	4-3-11.1
Air Intake and Emergency Shutdown Linkage.....	5-3-67
Air Intake Housing	4-3-11.2
Air Silencers	2-2-121
Alarm Switchboard	9-4-48
Alarm Switchboard.....	9-4-48.1
2-Line Alarm Panel	9-4-48.2
Alarm Switchboard	11-5-152
Alarm System.....	2-2-114
Alarm System - Test	2-2-117
- Turn - Off.....	2-2-118
- Turn - On	2-2-115
System Alarms.....	2-2-116
Amplifier/Loudspeaker.....	9-4-47.1
Amplifier/Loudspeaker.....	2-2-68
Anchor "A" Frame and Cable.....	11-5-81
Anchor "A" Frame and Control Station - Exterior Orientation.....	1-1-17
Anchor "A" Frame Hydraulic Directional Control Valve	7-3-201
Anchor "A" Frame Hydraulic Hoses, Fittings and Piping.....	7-3-202
Anchor "A" Frame Hydraulic Winch	7-3-200
Anchor Handling System - Maintenance Instructions.....	6-3-128
Air Cleaners.....	6-3-156
Air Intake	6-3-143
Balance Weight Cover	6-3-158
Blower.....	6-3-144
Camshaft and Gear Train.....	6-3-166
Crankshaft Vibration Dampener	6-3-157
Cylinder Head.....	6-3-164
Drive Brake and Brake Control.....	6-3-130
Drive Gear.....	6-3-131
Drum Assembly.....	6-3-133
Disconnect Clutch	6-3-135

INDEX (Continued)

Volume - Chapter
- Paragraph
or Table

A (continued)

Anchor Handling System - Maintenance Instructions - (Continued)	
Engine Assembly	6-3-140
Engine Controls	6-3-141
Engine Support and Lifting Brackets.....	6-3-159
Exhaust Manifold	6-3-160
Flywheel and Housing	6-3-167
Fresh Water Pump.....	6-3-150
Fuel Filter, Fuel Strainer, Fuel Lines and Manifold Connections	6-3-146
Fuel Injector.....	6-3-147
Fuel Pump	6-3-145
Governor and Breather Tube.....	6-3-142
Hydraulic Tank Assembly and Piping	6-3-137
Hydraulic Pump, Hoses, and Fittings.....	6-3-139
Injector Controls.....	6-3-162
Level Wind.....	6-3-132
Lube Oil Cooler.....	6-3-149
Lube Oil Distribution System.....	6-3-170
Lube Oil Filters, Hoses, and Housing.....	6-3-148
Lube Oil Pressure Regulator and By-Pass.....	6-3-168
Lube Oil Pump	6-6-169
Oil Pan and Dipstick.....	6-3-163
Overspeed Governor.....	6-3-154
Rocker Arm Cover	6-3-161
Slack Puller.....	6-3-184
Tachometer Drive	6-3-155
Thermostat and Housing	6-3-153
Torque Converter.....	6-3-136
Valve Operation Mechanism	6-3-165
Water Connections.....	6-3-151
Water Manifold	6-3-152
Winch	6-3-129
Winch, Brake Control	6-3-138
Anchor Inhaul - Anchor Winch	2-2-51
Anchor Winch Assembly.....	10-5-58
Anchor Winch.....	10-5-57
Disconnect Clutch Assembly	10-5-65
Disconnect Clutch	3-T3-50
Drive Brake Assembly.....	10-5-60
Drive Gear Assembly	10-5-61
Frame and Drum Assembly.....	10-5-63
Hydraulic Pump.....	3-T3-58

INDEX (Continued)

Volume - Chapter
- Paragraph
or Table

A (continued)

Anchor Winch (Continued)	
Hydraulic Tank.....	10-5-67
Balanced Piston Relief Valves	3-T3-52
Check Valves.....	3-T3-53
Directional Control Valve	3-T3-56
Hydraulic Tank.....	3-T3-57
Pressure Control Valves.....	3-T3-54
Pressure Reducing Valves	3-T3-55
Level Wind Assembly.....	10-5-62
Slack Puller.....	3-T3-49
Slack Puller and Motor Assembly	10-5-64
Torque Converter.....	3-T3-51
Torque Converter.....	10-5-66
Universal Joint Assembly	10-5-59
Winch	3-T3-48
Winch Assembly	10-5-58
Anchor Winch and "A" Frame	2-2-47
Anchor Winch - Anchor Inhaul.....	2-2-51
Anchor Winch Engine - Local Start/Stop Cold Weather.....	2-2-49
Anchor Winch Engine - Local Start/Stop Warm Weather	2-2-48
Anchor Winch - Remote Operation and Payout	2-2-50
Anchor Winch - Stop	2-2-52
Anchor Winch Assembly.....	10-5-58
Anchor Winch Compartment - Hydraulic Starting System	1-1-88
Anchor Winch Compartment - Interior Arrangement	1-1-34
Anchor Winch Controls - Controls and Indicators.....	1-2-17
Anchor Winch Engine.....	11-5-68
Abnormal Engine Coolant Operating Temperature	3-T3-66
Abnormal Engine Operation	3-T3-61
Blower.....	11-5-71
Cylinder Block.....	11-5-79
Emergency Start	2-2-187
Emergency Stop	2-2-185
Engine Assembly - Removal and Run In	11-5-69
Excessive Crankcase Pressure	3-T3-64
Exhaust Manifold	11-5-76
Exhaust Smoke Analysis.....	3-T3-59
Flywheel and Housing	11-5-77
Fresh Water Pump.....	11-5-73
Fuel Injector.....	11-5-72
Governor.....	11-5-70

INDEX (Continued)

Volume - Chapter
- Paragraph
or Table

A (continued)

Anchor Winch Engine (Continued)	
Hard Starting.....	3-T3-60
Hydraulic Reservoir.....	11-5-80
Hydrostarter	
Cranking Speed Too Low	3-T3-69
Fluid Emerges Around Rubber Boot of Hand Pump.....	3-T3-77
Fluid Emerges from the Reservoir Filler Cap When Starter Is Used.....	3-T3-76
Hand Pump Fails to Discharge Fluid.....	3-T3-72
High Pressure in System (3500 Psi (24,133 kPa) or above)	3-T3-75
Loss of Accumulator Precharge (Nitrogen),.....	3-T3-74
Loss of Fluid Pressure When Engine Is Not Running.....	3-T3-71
Loss of Fluid from Reservoir.....	3-T3-70
Starter Turns but Engine Does Not	3-T3-73
Local Start/Stop Cold Weather.....	2-2-49
Local Start/Stop Warm Weather	2-2-48
Low or High Exhaust Valve Opening Pressure	3-T3-67
Low or No Accumulator Pressure	3-T3-68
Low Oil Pressure.....	3-T3-65
Lube Oil Pump.....	11-5-78
No Fuel or Insufficient Fuel	3-T3-62
Principles of Operation.....	1-1-53
Restart After Emergency Stop.....	2-2-186
Thermostat and Housing.....	11-5-75
Water Manifold	11-5-74
Anchor Winch - Principles of Operation	1-1-56
Anchor Winch Room - Controls and Indicators.....	1-2-13
Anchor Winch - Stop.....	2-2-52
Anchor Winch System - Emergency Procedures.....	2-2-184
Anchor Winch Engine - Emergency Start	2-2-187
Anchor Winch Engine - Emergency Stop.....	2-2-185
Anchor Winch Engine - Restart After Emergency Stop	2-2-186
Cutting Anchor Cable	2-2-188
Anchor Winch System - Principles of Operation.....	1-1-52
"A" Frame	1-1-57
Anchor Winch	1-1-56
Anchor Winch Engine.....	1-1-53
Hydraulic System	1-1-55
Torque Converter.....	1-1-54
Applications - Portable Fire Pump.....	2-2-202
Automatic Electrical Shut-down System.....	5-3-65.3
Automatic Steering	2-2-61

INDEX (Continued)

Volume - Chapter
- Paragraph
or Table

B

Balanced Piston Relief Valves - Hydraulic Tank -	
Anchor Winch	3-T3-52
Balance Weight Cover - Anchor Winch.....	6-3-158
Balance Weight Cover - Generator.....	5-3-83
Balance Weight Cover and Accessory Drive.....	4-3-26
Balance Weight Cover and Accessory Drive.....	10-5-13
Ballast System.....	2-2-95
Draining Ballast Tanks - Using Fire Pump.....	2-2-99
- Using Gravity.....	2-2-97
Filling Ballast Tanks - Using Fire Pump.....	2-2-98
- Using Gravity.....	2-2-96
Ballast System Piping - Principles Of Operation	1-1-77
Battery Charger/Exhaust	2-2-131
Battery - Fire Pump (PE-250)	8-4-7.8A
Berth Light.....	5-3-111.9
Bilge System	2-2-86
Bilge Pump Shutdown	2-2-88
Draining Bilge with Bilge Pump and Fire Pump.....	2-2-94
Draining Bilge with Bilge Pump.....	2-2-87
Draining Bilge with Fire Pump and Eductor	2-2-92
Draining Bilge with Fire Pump.....	2-2-89
Draining the Fire Main System.....	2-2-91
Fire Pump , Bilge Draining Shutdown.....	2-2-90
Fire Pump and Eductor Shutdown.....	2-2-93
Bilge Pump.....	8-4-9
Bilge Pump Clutch	8-4-9.3
Bilge Pump Foundation and Drive.....	8-4-9.1
Bilge Pump	8-4-9.2
Bilge Pump Shutdown.	2-2 - 84
Bilge System Piping - Principles of Operation.....	1-1-76
Blower - Anchor Winch.....	11-5-71
Blower - Generator.....	10 5-35
Blower - Propulsion.....	10-5-8
Blower - Anchor Winch.....	6-3-144
Blower - Generator	5-3-68
Blower - Propulsion.....	4-3-12
Blower Heater.....	8-4-28.4
Bow Ramp.....	2-2-53,10-5-47
Bow Ramp, Sheaves , and Fairleads.....	10-5-48
Controller.....	10-5-52
Lowering Bow Ramp - Local.....	2-2-56
- Remote.....	2-2-54
Raising Bow Ramp - Local	2-2-57
- Remote.....	2-2-55

INDEX (Continued)

Volume - Chapter
- Paragraph
or Table

B (continued)

Bow Ramp (Continued)	
Speed Reducer	10-5-50
Winch Assembly	10-5-49
Winch Motor	10-5-51
Bow Ramp and Winch	6-3-115
Bow Ramp, Sheaves, and Fairleads.....	6-3-116
Controller	6-3-121
Limit Switch	6-3-123
Master Switches (Disconnect)	6-3-122
Speed Reducer	6-3-119
Torque Coupler 118	6-3-118
Winch Assembly	6-3-117
Winch Brake and Motor.....	6-3-120
Bow Ramp - Exterior Orientation	1-1-19
Bow Ramp, Sheaves, and Fairleads	6-3-116
Bow Ramp, Sheaves, and Fairleads	10-5-48
Bow Ramp System - Emergency Procedures.....	2-2-190
Bow Ramp - Lowering 2	2-2-191
- Raising	2-2-192
Bow Ramp Winch Brake.....	3-T3-46
Bow Ramp Winch Compartment and Deck Locker - Interior Arrangement	1-1-27
Bow Ramp Winch Systems - Principles of Operation	1-1-58
Bow Winch	3-T3-45
Bow Winch Motor	3-T3-47
Brake - Bow Ramp Winch.....	3-T3-46
Brake Valve - Hydraulic Cup Pump Unit	11-5-106
Break-Glass, Shut-Down Stations	2-2-206
Break Glass Station.....	5-3-110.2
Breather Tube - Governor - Generator.....	6-3-142.2

C

Call System Major Components.....	9-4-47.4
Camshaft Assembly and Gear Train	10-5-19
Camshaft Assembly and Gear Train.....	10-5-19.1
Idler Gear.....	10-5-19.2
Idler Gear Hole Spacer.....	10-5-19.3
Camshaft Assembly and Gear Train	10-5-19.1

INDEX (Continued)

Volume - Chapter
- Paragraph
or Table

C (continued)

Camshaft and Balance Shaft - Anchor Winch	6-3-166.5
Camshaft and Balance Shaft - Generator	5-3-91.5
Camshaft and Gear Train - Anchor Winch.	6-3-166
Camshaft and Balance Shaft.....	6-3-166.5
Crankshaft Timing Gear.....	6-3-166.4
Engine Timing.....	6-3-166.2
Gear Train.....	6-3-166.1
Idler Gear and Bearing Assembly.....	6-3-166.3
Camshaft and Gear Train - Generator	5-3-91
Camshaft and Balance Shaft.....	5-3-91.5
Crankshaft Timing Gear	5-3-91.4
Engine Timing.....	5-3-91.2
Gear Train.....	5-3-91.1
Idler Gear and Bearing Assembly.....	5-3-91.3
Carburetor Assembly - Fire Pump (P-250).....	8-4-7.2
Carburetor - Fire Pump (PE-250).....	8-4-7.7A
Carburetor Linkage, Control Panel and Manifold - Fire Pump (P-250).....	8-4-7.3
Centralized Hydraulic System	2-2-64
Anchor "A" Frame	2-2-68
Controller	3-T3-80
Hydraulic Power Unit.....	3-T3-79
Main Mast - Lowering	2-2-67
- Raising.....	2-2-66
Preliminary Adjustments	2-2-265
Stern Gate - Lowering.....	2-2-69
- Raising.....	2-2-70
Centralized Hydraulic System	7-3-186
Anchor "A" Frame Hydraulic System	
Hydraulic Control Valve.....	7-3-201
Hydraulic Winch.....	7-3-200
Hoses, Fittings and Piping.....	7-3-202
Mast Hydraulic System	
Hydraulic Control Valve.....	7-3-198
Hydraulic Ram	7-3-197
Hoses and Fittings.....	7-3-199
Ships' Hydraulic System	
Controller	7-3-191
Electric Motor and Coupling	7-3-188
Gage	7-3-192
Hydraulic Power Unit, Filters Return.....	7-3-187
Hydraulic Pump.....	7-3-189
Hydraulic Reservoir Tank.....	7-3-190
Pushbutton Switch.....	7-3-193

INDEX (Continued)

C (continued)

Volume - Chapter	
Centralized Hydraulic System (Continued)-.....	Paragraph
Stern Gate Hydraulic System	
Hydraulic Control Valve.....	7-3-194
Hydraulic Ram	7-3-196
Hoses and Fittings.....	7-3-195
Centralized Hydraulic System - Principles of	
Operation	1-1-81
Centrifugal Fan and Motor	8-4-27
Check Valves - Hydraulic Tank - Anchor Winch.....	3-T3-53
Check Valve - Hydraulic Tank -Anchor Winch	6-3-137.5
Circulating Fans.....	2-2-111
Clutch Hydraulic Cylinder	10-5-65.3
Coffee Maker	2-2-137, 9-4-41
Collection Tank Hoses and Gaskets	8-4-22.4
Commissary Space Equipment	9-4-37,11-5-146
Coffee Maker	9-4-41
Drinking Fountain.....	9-4-39
Galley Range	9-4-44
Milk Dispenser	9-4-40,11-5-148
Refrigerator/Freezer.....	9-4-38,11-5-147
Sanitizing Sink Heater.....	9-4-43
Toaster.....	9-4-45
Washer/Dryer.....	9-4-42
Communications (1JV and E)	2-2-153
Communication Systems - Principles of Operation	1-1-86
Compressor - Air Conditioner System.....	8-4-30
Compressor - HVAC	11-5-143
Compressor Controller - HVAC.....	11-5-145
Compressor Motor - HVAC	11-5-144
Condenser - Air Conditioner System.....	8-4-31
Connecting Rods - Anchor Winch	7-3-171.2
Connecting Rods - Generator	5-3-96.2
Connecting Rods - Propulsion.....	4-3-40.2
Connecting Rod Bearings - Anchor Winch	7-3-171.3
Connecting Rod Bearings - Generator	5-3-96.3
Connecting Rod Bearings - Propulsion.....	4-3-40.3
Conning Tower	1-23.1, 2-163, 2-666.1
Contact - Fire Pump Controller	11-5-121.1
Controls and Indicators - Sewage System.....	8-4-21
Control Station.....	4-3-9.1
Control Unit and Linkage	4-3-9.2
Controller.....	9-4-36.8
Controller.....	10-5-52

INDEX (Continued)

Volume - Chapter
- Paragraph
or Table

C (continued)

Controller - Anchor Winch.....	7-3-191
Controller - Bow Ramp	6-3-121
Controller - Centralized Hydraulic System.....	3-T3-80
Controller - Hydraulic Cub Pump Unit.....	11-5-104
Controller - Sewage System	8-4-21.1
Controller - Ship's Hydraulic System.....	11-5-89
Corrosion Prevention Anodes	11-6-5
Cranking Speed Too Low - Hydrostarter - Anchor Winch 3-T3-69	
Cranking Speed Too Low - Hydrostarter	3-T3-32
Crankshaft - Anchor Winch.....	7-3-172
Crankshaft h.....	3-172.2
Crankshaft Bearings.....	7-3-172.1
Crankshaft Seals.....	7-3-172.3
Crankshaft - Generator	5-3-97
Crankshaft	5-3-97.2
Crankshaft Bearings.....	5-3-97.1
Crankshaft Seals.....	5-3-97.3
Crankshaft - Propulsion	4-3-42
Crankshaft and Main Bearings.....	7-3.172
Crankshaft and Piston - Fire Pump (P-250).....	8-4-7.7
Crankshaft Bearings - Anchor Winch	7-3-172.1
Crankshaft Bearings - Propulsion.....	4-3-41
Crankshaft Pulley	5-3-82
Crankshaft Pulley and Vibration Damper	4-3-25
Crankshaft Seals - Anchor Winch.....	7-3-172.3
Crankshaft Seals - Generator	5-3-97.3
Crankshaft Seals - Propulsion.....	4-3-43
Crankshaft Timing Gear - Anchor Winch	6-3-166.4
Crankshaft Timing Gear - Generator.....	5-3-91.4
Crankshaft Vibration Damper.....	6-3-157
Crew and Transient Berthing - Controls and Indicators	1-2-9
Crew and Transient Berthing - Interior Arrangement	1-1-30
Cub Hydraulic Pump Unit - Principles of Operation.....	1-1-60
Cutting Anchor Cable.....	2-2-188
Cylinder Assemblies	9-4-46.4
Cylinder Block - Anchor Winch	11-5-79
Cylinder Block - Generator.....	10-5-43
Cylinder Block - Propulsion.....	10-5-20
Cylinder Block - Anchor Winch	7-3-173
Cylinder Block - Generator.....	5-3-98
Cylinder Block - Propulsion.....	4-3-44

INDEX (Continued)

Volume - Chapter
- Paragraph
or Table

C (continued)

Cylinder Head - Anchor Winch.....	6-3-164
Cylinder Head	6-3-164.1
Fuel Injector Tube	6.. 6-3-164.2
Cylinder Head - Generator	5-3-89
Cylinder Head	5-3-89.1
Fuel Injector Tube	5-3-89.2
Cylinder Head - Propulsion	4-3-34
Fuel Injector Tube	4-3-34.1
Cylinder Liner - Anchor Winch	7-171.4
Cylinder Liner - Generator	5-3-96.4
Cylinder Liner - Propulsion.....	4-3-40.4
Cylinder and Linkage - Hydraulic Cub Pump Unit.....	11-5-108

D

Damage Control	2-2-194
Break-Glass, Shut-Down Stations.....	2-2-206
Emergency Lighting	2-2-205
Fire Fighting.....	2-2-195
Salvage Pump	2-2-207
Watertight Integrity.....	2-2-208
Darken Ship.....	2-2-130
Deck Fittings.....	9-4-65,11-5-180
Deck and Sanitary Drains	11-5-173
Deck and Sanitary Drain Piping System - Principles of Operation	1-1-73
Destruction of Army Materiel to Prevent Enemy Use	1-1-3
Diesel Oil Cooling Piping	9-4-59
Diesel Oil Cooling Pump.....	8-4-13
Diesel Oil Cooling Pump Motor Controller	8-4-13.4
Diesel Oil Cooling Pump Motor	8-4-13.3
Diesel Oil Cooling Pump	8-4-13.2
Diesel Oil Cooling Pump Set.....	8-4-13.1
Diesel Oil Cooling Pump Motor.....	11-5-129
Diesel Generator and Propulsion Engine - Hydraulic Starting System - Principles of Operation	1-1-89
Diesel Oil Piping.....	9-4-58,11-5-165
Diesel Oil Stowage Tank.....	9-4-57
Differences Between Models	1-1-38

INDEX (Continued)

Volume - Chapter
- Paragraph
or Table

D (continued)

Directional Control Valve - Hydraulic Tank - Anchor Winch.....	3-T3-56
Directional Control Valve	7-3-208
Directional Valve - Pilot Operated - Hydraulic Tank - Anchor Winch.....	6-3-137.6
Directional Valve - Spring Centered Solenoid - Hydraulic Tank - Anchor Winch	6-3-136.9
Discharge Piping - Sewage System	8-4-22.2
Discharge Pump - Sewage System.....	8-4-19
Discharge Valve - Fire Pump (PE-250).....	8-4-7.3A
Disconnect Clutch Assembly.....	10-5-65.1
Disconnect Clutch - Anchor Winch.....	3-T3-50
Disconnect Clutch.....	6-3-135,10-5-65 10-5-65. 2
Disconnect Clutch.....	10-5-65
Clutch Hydraulic Cylinder.....	10-5-65.3
Disconnect Clutch Assembly	10-5-65.1
Disconnect Clutch	10-5-65.2
Disconnect Switch	5-3-1-106
Distribution Lighting Panels	10-5-45
Distribution Panels Lighting	5-3-109
Lighting Distribution Panels.....	5-3-109.1
Terminal Boxes.....	5-3-109.2
Docking	2-2-158
Aircraft Flood Lights	2-2-166
Exhaust Stacks.....	2-2-172
Floodlight	2-2-171
Jack and Ensign Staff, Signal Flag.....	2-2-170
Lifeboats.	2-2-162
Machine Gun Tripod Mount.....	2-2-164
Main Mast	2-2-65
Radar Mast.....	2-2-159
Ready Service Locker	2-2-165
Searchlight.....	2-2-167
Ships Course Indicator and Peloris.....	2-2-168
Stern Gate Davits.....	2-2-159
Voice Tube.....	2-2-161
Whip Antennas.....	2-2-160
Windscreen and Railings.....	2-2-163
Doors, Hatches, Scuttles and Manholes.....	9-4-74
Doors, Hatches, and Scuttles.....	11-5-176
Drain Piping - Sewage System	8-4-22.3
Draining Ballast Tanks - Using Fire Pump.....	2-2-99
- Using Gravity	2-2-97

INDEX (Continued)

Volume - Chapter
- Paragraph
or Table

D (continued)

Draining Bilge with Bilge Pump and Fire Pump.....	2-2-94
Draining Bilge with Bilge Pump.....	2-2-87
Draining Bilge with Fire Pump and Eductor.....	2-2-92
Draining Bilge with Fire Pump.....	2-2-89
Draining the Fire Main System.....	2-2-80, 2-2-91
Drinking Fountain	2-2-140,9-4-39
Drive Brake Assembly	10-5-60
Drive Brake and Brake Control	6-3-130
Drive Gear Assembly.....	10-5-61
Drive Gear.....	6-3-131
Drum Assembly	6-3-133
Dryer Mechanism	9-4-42.3
Dryer Operation.....	2-2-145
Duct Heaters.....	8-4-28.2
Duplex Receptacles.....	5-3-110.4
Duplex Strainer.....	9-4-60

E

Electric Motor	11-5-85
Electric Motor and Coupling.....	7-3-188
Electric Power Generation and Distribution.....	10-5-28
Blower.....	10-5-35
Cylinder Block.....	10-5-43
Distribution Lighting Panels.....	10-5-45
Engine Assembly	10-5-33
Exhaust Manifold	10-5-40
Flywheel and Housing	10-5-41
Fresh Water Pump.....	10-5-37
Fuel Injector.....	10-5-36
Generator.....	10-5-32
Governor.....	10-5-34
Lube Oil Pump.....	10-5-42
Main Switchboard.....	10-5-29
Power Panel Boards.....	10-5-31
Running Light Control Panel.....	10-5-46
Thermostat and Housing	10-5-39
Transformers.....	10-5-30
24-Volt Rectifier	10-5-44
Water Manifold	10-5-38

INDEX (Continued)

Volume - Chapter
- Paragraph
or Table

E (continued)

Electric Power Generation and Distribution -

Maintenance Instructions.....	5-3-58
Accumulator.....	5-3-102
Air Cleaner.....	5-3-81
Air Intake	5-3-67
Balance Weight Cover	5-3-83
Blower.....	5-3-68
Camshaft and Gear Train.....	5-3-91
Crankshaft	5-3-97
Crankshaft Pulley.....	5-3-82
Cylinder Block.....	5-3-98
Cylinder Head.....	5-3-89
Distribution Panels Lighting.....	5-3-109
Emergency Lighting	5-3-112
Engine Assembly	5-3-64
Engine Controls	5-3-65
Exhaust Manifold	5-3-85
Expansion Tank Water Connections.....	5-3-76
Flywheel and Housing	5-3-92
Fresh Water Pump.....	5-3-75
Fuel Filter, Strainer and Fuel Lines	5-3-70
Fuel Injector.....	5-3-71
Fuel Lines and Manifold Connections.....	5-3-72
Fuel Pump	5-3-69
Generator (12 V)	5-3-62
Generator (40 Kw).....	5-3-63
Governor (Hydraulic).....	5-3-66
Hydrostarter	5-3-101
Hydrostarter Piping (Aft Engine Room).....	5-3-106
Hydrostarter Piping (Forward Engine Room)	5-3-105
Hydrostarter Pump (Engine-Driven)	5-3-103
Hydrostarter Pump (Hand)	5-3-104
Hydrostarter Reservoir, Filter, and Solenoid.....	5-3-107
Injector Controls.....	5-3-87
Instrument Panel.....	5-3-99,
Lifter Brackets and Supports	5-3-84
Lights.....	5-3 111
Lube Oil Cooler.....	5-3-74
Lube Oil Distribution System.....	5-3-95
Lube Oil Filters and Housing/Breather	5-3-73
Lube Oil Pump.....	5-3-94
Lube Oil Pressure Regulator and By-Pass.....	5-3-93
Navigational Light Control Panel	5-3-114 1

INDEX (Continued)

Volume - Chapter
- Paragraph
or Table

E (continued)

Electric Power Generation and Distribution - Maintenance Instructions (Continued)	
Oil Pan, Dipstick and Oil Filler.....	5-3-88
Overspeed Governor.....	5-3-79
Panel Boards - Power Distribution and Shore Power	
Connection Box.....	5-3-61
Pistons, Connecting Rods and Cylinder Liners	5-3-96
Rectifier 24 VDC	5-3-108
Rocker Arm Cover	5-3-86
Running Signal and Anchor Lights.....	5-3-113
Switches	5-3-110
Switchboard (Main)	5-3-59
Starting Aid.....	5-3-100
Tachometer Drive e	5-3-80
Thermostat and Housing	5-3-78
Transformers.....	5-3-60
Valve Operating Mechanism	5-3-90
Water Manifold	5-3-77
Electric Range	2-2-136
Electric Turret Heaters.....	8-4-28.1
Electronic Devices	2-2-132
Electronic and Navigation Systems.....	9-4-49
Electronics Foundations	9-4-49.1
Navigation Horn.....	9-4-49.2
24 Volt Distribution Panel.....	9-4-49.3
Electronics Foundations.....	9-4-49.1
Emergency Life Saving Equipment - Exterior	
Orientation	1-1-13
Emergency Lighting.....	2-2-205,5-3-112
Incandescent Lighting Fixture - Symbol 98.1.....	5-3-112.1
Portable Lantern.....	5-3-112.3
Relay Operated Lantern	5-3-112.2
Emergency Procedures	2-2-174
Anchor Winch System.....	2-2-184
Bow Ramp System.....	2-2-190
Emergency Steering.....	2-2-189
Generating System	2-2-180
Propulsion System	2-2-175
Stern Gate	2-2-193
Emergency Shutdown - Controls and Indicators.....	1-2-16
Emergency Shutdown - Head and Linkage - Generator.....	5-3-65.1
Emergency Shutdown Head and Linkage - Propulsion.....	4-3-9.3

INDEX (Continued)

Volume - Chapter
- Paragraph
or Table

E (continued)

Emergency Steering	2-2-189
Emergency Steering Components - Exterior Orientation	1-1-18
Emergency Steering System	7-3-218
Emptying Holding Tank.....	2-2-104
Engine Access Room - Controls and Indicators.....	1-2-5
- Interior Arrangement	1-1-26
Engine Assembly - Anchor Winch.....	6-3-140
Engine Assembly - Generator	5-3-64
Engine Assembly - Removal and Run-In - Anchor Winch	11-5-69
Engine Assembly - Removal and Run-In - Generator.....	10-5-33
Engine Clutch and Throttle Controls	6-3-141.1
Engine Controls - Anchor Winch.....	6-3-141
Engine Clutch and Throttle Controls	6-3-141.1
Engine Throttle Linkage.....	6-3-141.2
Stop Cable and Linkage	6-3-141.3
Engine Controls - Generator	5-3-65
Automatic Electrical Shut-down System	5-3-65.3
Fuel Oil Pressure Alarm Switch.....	5-3-65.3.3
Lubricating Oil Pressure Alarm Switch.....	5-3-65.3.4
Time Delay Relay.....	5-3-65.3.1
Water Temperature Alarm Switch	5-3-65.3.2
Emergency Shut-down - Head and Linkage	5-3-65.1
Shut-down Solenoid d.....	5-3-65.2
Engine Control Panel - Fire Pump (PE-250)	8-4-7.1A
Engine Cooling Water System - Principles of Operation	1-1-67
Engine Exhaust	9-4-60
Engine Exhaust Piping.....	11-5-167
Engine - Fire Pump (PE-250).....	8-4-7.10A
Engine Lube Oil Transfer System - Principles Of Operation	1-1-70
Engine Supports and Lifting Brackets - Anchor Winch	6-3-159
Engine Supports, Lifter Brackets and Crankshaft Front Cover - Propulsion	4-3-27
Engine Supports, Lifter Bracket, and Crankshaft Front Cover 10r5.1	10-5-14
Engine Throttle Linkage.....	6-3-141.2
Engine Timing - Anchor Winch	6-3-166.2
Engine Timing - Generator	5-3-91.2
Engine/Transmission Controls	4-3-9
Control Station	4-3-9.1
Control Unit and Linkage.....	4-3-9.2
Emergency Shutdown Head and Linkage	4-3-9.3
Lubricating Oil Pressure Switch.....	4-3-9.5
Water Temperature Switch.....	4-3-9.4

INDEX (Continued)

Volume - Chapter
- Paragraph
or Table

E (continued)

Engine and Transmission Controls.....	1-5-6
Entertainment Amplifier	2-2-135
Equipment Data.....	1-1-39
Equipment Purpose, Capabilities and Features.....	1-1-8
Equipment and Repair Parts Stores - Controls and Indicators	1-2-8
Equipment and Repair Parts Stores - Interior Arrangement	1-1-29
Equipment and Repair Parts Stores - Ordnance	1-1-31
Excessive Crankcase Pressure - Anchor Winch Engine.....	3-T3-64
Excessive Crankcase Pressure - Generator	3-3-27
Excessive Crankcase Pressure - Propulsion	3-T3-6
Exhaust Fan Controller - HVAC	11-5-141
Exhaust Fan Motor - HVAC	11-5-142
Exhaust Manifold - Anchor Winch.....	11-5-76
Exhaust Manifold - Generator	10-5-40
Exhaust Manifold - Anchor Winch.....	6-3-160
Exhaust Manifold - Generator	5-3-85
Exhaust Manifold and Fittings.....	4-3-28
Exhaust Pipe Hangers	11-5-160
Exhaust Piping System - Principles of Operation	1-1-68
Exhaust Smoke Analysis - Anchor Winch Engine	3-T3-59
Exhaust Smoke Analysis - Generator.....	3-T3-22
Exhaust Smoke Analysis - Propulsion.....	3-T3-1
Exhaust Stacks.....	2-2-172
Exhaust System Piping.....	8-4-62
Insulation.....	8-4-62.1
Piping.....	8-4-62.2
Exhaust Valve - Anchor Winch	6-3-165.2
Exhaust Valve - Generator	5-3-90.2
Exhaust Valve - Propulsion.....	4-3-33. 2
Expansion Tank.....	10-5-10
Expansion Tank.....	4-3-19
Expansion Tank and Water Connections	5-3-76
Exterior Cabinet Removal.....	9-4-42.1
Exterior Orientation	
Anchor "A" Frame and Control Station.....	1-1-17
Bow Ramp.....	1-1-19
Emergency/Life Saving Equipment.....	1-1-13
Emergency Steering Components	1-1-18
First Aid Equipment.....	1-1-16
Machine Gun, Ready Service Lockers and Grenade Lockers	1-1-14

INDEX (Continued)

E (continued)	Volume - Chapter - Paragraph or Table
Exterior Orientation (Continued)	
Miscellaneous Components on Cargo Deck.....	1-1-21
Mooring, Towing, Causeway Fittings and Locking	
Gear.....	1-1-15
Stern Gate.....	1-1-20
F	
Fairleader	7-3-183
Fairleader - Anchor "A" Frame.....	11-5-82
Filling Ballast Tanks - Using Fire Pump	2-2-98
Filling Ballast Tanks - Using Gravity	2-2-96
Fire Alarm Panel.....	4-46.2 1
Fire, Ballast and Bilge Piping.....	11-5-161
Fire, Bilge and Ballast Piping.....	9-4-54
Fog Nozzle.....	9-4-54.5
Gage Piping	9-4-54.2
Piping.....	9-4-54.1
Simplex Strainer.....	9-4-54.3
Wye Strainer	9-4-54.4
Fire, Bilge, and Ballast System	2-2-76
Ballast System	2-2-95
Bilge System	2-2-86
Fire System.....	2-2-77
Fire Detection/Extinguishing System	11-5-149
Fire Detection/Extinguishing System	9-4-46
Fire Alarm Panel.....	4-46.2
Cylinder Assemblies.....	9-4-46.4
Fire Fighting System	9-4-46.1
Halon Control Panel	9-4-46.2
Smoke Detector	9-4-46.3
Fire Fighting	2-2-195
Fire Main System	2-2-196
Halon Fixed System	2-2-197
Liquid Foam	2-2-204
Portable Extinguishers.....	2-2-198
Portable Fire Pump	2-2-199
Fire Fighting System.....	9-4-46.1
Fire Fighting Systems - Interior Arrangements.....	1-1-37
Fire Mains and Fire Plugs.....	2-2-78

INDEX (Continued)

Volume - Chapter
- Paragraph
or Table

F (continued)

Fire Main	2-2-196
Draining the Fire Main System	2-2-80
Fire Mains and Fire Plugs	2-2-78
Fire Pump - Shutdown.....	2-2-79
Fire Pump	11-5-119
Fire Pump	8-4-8
Fire Pump Motor Controller	8-4-8.4
Fire Pump Motor	8-4-8.3
Fire Pump	8-4-8.2
Fire Pump Set.....	8-4-8.1
Simplex Strainer.....	8-4-8.5
Fire Pump, Bilge Draining Shutdown	2-2-90
Fire Pump Controller	11-5-121
Contactor	11-5-121.1
M-Type Relay.....	11-5-121.3
Starter (NEMA, Size 3, 3 Pole Reversing)	11-5-121.2
Fire Pump and Eductor Shutdown	2-2-93
Fire Pump Motor.....	11-5-120 O
Fire Pump - Shutdown	2-2-79
Fire System	2-2-77
Draining the Fire Main System	2-2-80
Fire Mains and Fire Plugs.....	2-2-78
Fire Pump - Shutdown.....	2-2-79
Magazine Sprinkler.....	2-2-81
Peak Ballast Tank Filling	2-2-83
Sewage Tank Flushing	2-2-84
Washdown countermeasure Sprinkling System	2-2-82
Fire System Piping - Principles of Operation.....	1-1-75
First Aid Equipment - Exterior Orientation.....	1-1-16
Flanking Rudder Limit Switch	11-5-113
Flanking Rudder Limit Switch	7-3-214
Flanking Rudder Limit Switch Assembly - Principles of Operation	1-1-63
Floodlight.....	2-2-171
Floodlight.....	5-3-111.4
Fluid Emerges Around Rubber Boot of Hand Pump - Hydrostarter - Anchor Winch	3-T3-77
Fluid Emerges Around Rubber Boot of Hand Pump - Hydrostarter	3-T3-40
Fluid Emerges Around Rubber Boot of Hand Pump - Propulsion	3-T3-20

INDEX (Continued)

Volume - Chapter
- Paragraph
or Table

F (continued)

Fluid Emerges from Ends of Starter Control Valve When Starter Is Operated - Hydrostarter	3-T3-41
Fluid Emerges from Ends of Starter Control Valve When Starter is Operated - Propulsion	3-T3-21
Fluid Emerges from the Reservoir Filler Cap When Starter Is Used - Hydrostarter - Anchor Winch	3-T3-76
Fluid Emerges from Reservoir Filler Cap When Starter Is Used - Hydrostarter	3-T3-39
Fluid Emerges from the Reservoir Filler Cap When Starter Is Used - Propulsion.....	3-T3-19
Fluorescent Desk Lamp	5-3-111.5
Flush Water Pump Motor.....	11-5-133
Flush Water Pump.....	8-4-20
Flush Water Pump Motor Controller	8-4-20.4
Flush Water Pump Motor	8-4-20.3
Flush Water Pump	8-4-20.2
Flush Water Pump Set.....	8-4-20.1
Flushing System	2-2-108
Flushing System Piping - Principles of Operation.....	1-1-78
Flywheel - Anchor Winch.....	6-3-167.1
Flywheel - Generator	5-3-92.1
Flywheel and Housing - Anchor	11-5-77
Flywheel and Housing - Generator.....	1-5-41
Flywheel and Housing - Propulsion	10-5-18
Flywheel and Housing - Anchor	6-3-167
Flywheel	6-3-167.1
Flywheel Housing	6-3-167.2
Flywheel and Housing - Generator.....	5-3-92
Flywheel.....	5-3-92.1
Flywheel Housing.....	5-3-92.2
Flywheel and Housing - Propulsion.....	4-3-32.1
Flywheel and Housing and Oil Breather	4-3-32
Flywheel and Housing	4-3-32.1
Oil Breather.....	4-3-32.2
Flywheel Housing - Anchor Winch	6-3-167.2
Flywheel Housing - Generator.....	5-3-92.2
Fog Nozzle	9-4-54.5
Foot Valve Assembly - Fire Pump (P-250).....	8-4-7.8
Forward Engine Room - Controls and Indicators.....	1-2-11
Forward Engine Room - Interior Arrangement.....	1-1-32
Frame and Drum Assembly	10-5-63
Fresh and Flush Water Piping	9-4-64,11-5-168
Fresh Water Pump - Anchor Winch	11-5-73
Fresh Water Pump - Generator	10-5-37

INDEX (Continued)

Volume - Chapter
- Paragraph
or Table

F (continued)

Fresh Water Pump - Anchor Winch	6-3-150
Fresh Water Pump - Generator	5-3-75
Fresh Water Pump - Propulsion.....	4-3-18
Fresh Water Pump	8-4-11
Fresh Water Pump Motor Controller.....	8-4-11.4
Fresh Water Pump Motor.....	8-4-11.3
Fresh Water Pump.....	8-4-11.2
Fresh Water Pump Set.....	8-4-11.1
Fresh Water Pump Controller.....	11-5-126
Fresh Water Pump Motor	11-5-125
Fresh Water System.....	2-2-74
Fresh Water System Piping - Principles of Operation	1-1-72
Fuel Filter, Fuel Strainer, Fuel Lines and Manifold Connections	6-3-146
Fuel Filter.....	6-3-146.1
Fuel Lines and Manifold Connections.....	6-3-145.3
Fuel Strainer	6-3-145.2
Fuel Filter, Strainer and Fuel Lines.....	4-3-14
Fuel Filter.....	4-3-14.1
Fuel Lines	4-3-14.3
Fuel Strainer	4-3-14.2
Fuel Filter and Strainer.....	5-3-70
Fuel Filter.....	5-3-70.1
Fuel Strainer	5-3-70.2
Fuel Filter - Anchor Winch.....	6-3-146.1
Fuel Filter - Generator	5-3-70.1
Fuel Filter - Propulsion	4-3-14.1
Fuel Injector - Anchor Winch	11-5-72
Fuel Injector - Generator.....	10-5-36
Fuel Injector - Propulsion.....	1-5-9
Fuel Injector - Anchor Winch	6-3-147
Fuel Injector - Generator.....	5-3-71
Fuel Injector - Propulsion.....	4-3-15
Fuel Injector Controls - Generator.....	4-3-87
Fuel Injector Controls - Propulsion.....	4-3-31
Fuel Injector Tube - Anchor	6-3-164.2
Fuel Injector Tube - Generator.....	5-3-89.2
Fuel Injector Tube - Propulsion.....	4-3-34.1
Fuel Lines.....	4-3-14.3
Fuel Lines and Manifold Connections - Anchor Winch	6-3-146.3
Fuel Lines and Manifold Connections - Generator.....	5-3-72
Fuel Oil Pressure Alarm Switch	5-3-65.3.3
Fuel Pump.....	4-3-13

INDEX (Continued)

Volume - Chapter
- Paragraph
or Table

F (continued)

Fuel Pump and Drain Lines - Anchor Winch	6-3-145
Fuel Pump and Drain Lines - Generator.....	5-3-69
Fuel Tank Assembly - Fire Pump (P-250).....	8-4-7.4
Fuel Strainer - Anchor Winch.....	6-3-146.2
Fuel Strainer - Generator.....	4-3-70.2
Fuel Strainer - Propulsion	4-3-14.2
Fuel System	2-2-28
Fuel System - Principles of Operation.....	1-1-69
Furniture and Miscellaneous Furnishings.....	9-4-72,11-5-175

G

Gages.....	11-5-89
Gage Board.....	8-4-34
Gage and Iso1ator.....	7-3-192
Gage Panel - Fire Pump (PE-250).....	8-4-7.2A
Gages Panel - Sewage System.....	8-4-21. 1
Gage Piping.....	9-4-54.2
Galley and Mess.....	2-2-133
Coffee Maker	2-2-137
Drinking Fountain.....	2-2-140
Electric Range	2-2-136
Entertainment Amplifier.....	2-2-135
Milk Dispenser.....	2-2-138
Refrigerator/Freezer.....	2-2-139
Sanitizing Sink Heater.....	2-2-141
Toaster.....	2-2-134
Galley and Mess Room - Controls and Indicators.....	1-2-3
- Interior Arrangement.....	1-1-24
Galley Range.....	9-4-44
Gate, Hinges and Springs.....	10-5-55
Gate, Hinges, Springs - Stern Gate.....	6-3-126
Gear Train - Anchor Winch.....	6-3-166.1
Gear Train - Generator	5-3-91.1
General	7-3-220,8-4-1, 8-4-4, 8-4-5
Operations Under Unusual Conditions.....	2-2-173
Operations Under Usual Conditions.....	2-2-20
General Familiarization.....	1-1-10
General Information - Scope.....	1-1-1
General Lubrication	3-3-4

INDEX (Continued)

Volume - Chapter
- Paragraph
or Table

G (continued)

General Repair Parts, Special Tools, TMDE and Support Equipment.....	3-3-1
General - Repair Parts, Special Tools, TMDE and Support Equipment.....	10-5-1
General Support Maintenance Instructions	
Corrosion Prevention Anodes.....	11-6-5
Propeller Shaft and Bearings.....	11-6-1
Remote Magnetic Heading Compass	11-6-4
Shaft Seals	11-6-2
Steering Control Panel and Gyro Computer	11-6-3
General Purpose Fluorescent Fixture (1 Tube)	5-3-111.7
General Purpose Fluorescent Fixture (2 Tube)	5-3-111.6
General Troubleshooting - Symptom Index.....	3-3-5
General - Troubleshooting	1-5-2
Generator	3-T3-42
Generator (12 VDC).....	5-3-62
Generator (12 VDC)	5-3-62.1
Voltage Regulator	5-3-62.2
Generator (40 Kw)	5-3-63
Generator (40 Kw)).....	10-5-32
Generator - Principles of Operation	1-1-48
Generator Engine	
Abnormal Engine Coolant Operating Temperature	3-T3-29
Abnormal Engine Operation	3-T3-24
Cold Weather Start	2-2-39
Emergency Start	2-2-183
Emergency Stop	2-2-181
Excessive Crankcase Pressure	3-T3-27
Exhaust Smoke Analysis.....	3-T3-22
Hard Starting.....	3-T3-23
High Lubricating Oil Consumption	3-T3-26
Local Start.....	2-2-38
Local Stop.....	2-2-45
Generator Engine - Principles of Operation.....	1-1-47
Generating System - Emergency Procedures	2-2-180
Generator Engine - Emergency Start.....	2-2-183
- Emergency Stop.....	2-2-181
- Reset After Emergency Stop	2-2-182
Generating System.....	2-2-35
Generator Engine - Cold Weather Start.....	2-2-39
- Local Starting	2-2-38
- Local Stop	2-2-45
Ground Detector Lights	2-2-46
Paralleling Generator	2-2-42

INDEX (Continued)

Volume - Chapter
- Paragraph
or Table

G (continued)

Generating System (Continued)	
Preliminary Adjustments.....	2-2-37
Remote Operation - Generator #1.....	2-2-40
- Generator #2.....	2-2-41
Shore Power.....	2-2-36
Stopping Generator - Operating Non-Parallel.....	2-2-43
- Operating Parallel.....	2-2-44
Governor - Anchor Winch.....	11-5-70
Governor - Generator.....	10-5-34
Governor - Anchor Winch.....	6-3-142.1
Governor - Hydraulic - Generator.....	5-3-66
Governor (Hydraulic).....	5-3-66.1
Governor Oil Filter.....	5-3-66.2
Synchronizing Motor.....	5-3-66.3
Governor - Propulsion.....	4-3-10
Governor and Breather Tubes.....	6-3-142
Breather Tubes.....	6-3-142.2
Governor.....	3-142.1
Governor (Hydraulic) - Generator.....	5-3-66.1
Governor Oil Filter.....	5-3-66.2
Ground Detector Lights.....	2-2-46

H

Halon Control Panel.....	9-4-46.2
Halon Fixed System.....	2-2-197
Alarms.....	2-2-121
Halon System.....	2-2-119
Reactivation.....	2-2-122
Testing.....	2-2-123
Turn-On.....	2-2-120
Halon System.....	2-2-119
Alarms (Automatic - Manual - Remote Manual).....	2-2-121
Reactivation.....	2-2-122
Testing.....	2-2-123
Turn-On.....	2-2-120
Halon Systems - Principles of Operation.....	1-1-82
Hand Crank Interlock Limit.....	6-3-123.2
Hand Pump Fails to Discharge Fluid - Hydrostarter - Anchor Winch.....	3-T3-72

INDEX (Continued)

Volume - Chapter
- Paragraph
or Table

H (continued)

Hand Pump Fails to Discharge Fluid - Hydrostarter.....	3-T3-35
Hand Pump Fails to Discharge Fluid - Propulsion	3-T3-15
Hand Receipts.....	1-1-7
Hard Starting - Anchor Winch Engine	3-T3-60
Hard Starting - Generator	3-T3-23
Heading Selector.....	3-T3-89
Heading Selector.....	7-3-216
Heading Selector - Principles of Operation	1-1-61
Heat Exchanger Tank.....	4-3-19
Heat Interchanger.....	9-4-36.3
Heaters.....	2-2-125
Heating, Ventilation and Air Conditioning Systems - Principles Of Operation.....	1-1-80
Heating, Ventilation, and Air Conditioner System.....	8-4-24
Air Conditioner System.....	8-4-29
HVAC Ducting.....	8-4-26
HVAC Exhaust Fan and Motor	8-4-27
HVAC Heating System	8-4-28
HVAC Supply Fan and Motor	8-4-25
Heating, Ventilation and Air Conditioning System	11-5-137
Compressor.....	11-5-143
Compressor Controller	11-5-145
Compressor Motor.....	11-5-144
Exhaust Fan Controller.....	11-5-118
Exhaust Fan Motor	11-5-142
HVAC Ducting.....	11-5-140
Recirculating Fan Controller.....	11-5-138
Recirculating Fan Motor	11-5-139
High Intensity Light.....	9-4-77
High Lubricating Oil Consumption - Generator.....	3-T3-26
High Pressure in System (3500 Psi (24,133 kPa) or above) - Hydrostarter - Anchor Winch	3-T3-75
High Pressure in System (3500 psi (24,133 kPa) or above) - Hydrostarter	3-T3-38
High Pressure in System (3500 psi (24,133 kPa) or above) - Propulsion	3-T3-18
Holding Tank - Sewage System	8-4-23
Hood Assembly	2-2-150
Horns (NH and 5U)	2-2-154
Hose and Fittings - Mast Hydraulic System.....	11-5-98
Hose and Fittings - Stern Anchor Hydraulic System.....	11-5-101
Hose, Fittings, and Piping.....	11-5-93
Hose, Piping, and Valves - Hydraulic Cub Pump Unit	11-5-109
Hoses, Lines and Fittings.....	6-3-139.2

INDEX (Continued)

Volume - Chapter
- Paragraph
or Table

H (continued)

Hot Water Heater	11-5-171
Hot Water Heater	9-4-67
Housing/Breather.....	6-3-73.2
Hull and Outfit.....	9-4-70
Doors, Hatches, Scuttles and Manholes.....	9-4-74
Furniture and Misc. Furnishings.....	9-4-72
High Intensity Light.....	9-4-77
Lashing Gear.....	9-4-80
Mooring and Towing Fittings.....	9-4-76
Portable Air Compressor.....	9-4-73
Searchlight.....	9-4-79
Stanchions and Railings.....	9-4-71
Windscreen and Airports.....	9-4-75
Windshield Wiper.....	9-4-78
HVAC Ducting	1-5-137
HVAC Ducting	8-4-26
HVAC Exhaust Fan and Motor.....	8-4-27
HVAC Heating System	8-4-28
Blower Heater	8-4-28.4
Duct Heaters.....	8-4-28.2
Electric Turret Heaters	8-4-28.1
Thermostats.....	8-4-28.3
HVAC Supply Fan and Motor.....	8-4-25
Hydraulic Cub Pump Unit - Brake Valve.....	7-3-207
Hydraulic Cub Pump Unit - Directional Control Valve.....	7-3-208
Hydraulic Cub Pump Unit - Hydraulic Pump.....	7-3-206
Hydraulic Cub Pump Unit - Hydraulic Reservoir, Tank and Strainer	7-3-209
Hydraulic Cub Pump Unit - Motor.....	7-3-204
Hydraulic Cub Pump Unit - Motor Controller.....	7-3-205
Hydraulic Cub Pump Unit - Brake Valve	11-5-106
Controller.....	11-5-104
Cylinder and Linkage.....	11-5-108
Hoses, Piping and Valves.....	11-5-109
Motor	11-5-103
Pump	11-5-105
Reservoir, Tank and Strainer.....	11-5-107
Hydraulic Controller and Flow Control Manifold.....	11-5-97
Hydraulic Controller and Flow Valve.....	11-5-92
Hydraulic Cylinder - Mast Hydraulic System.....	11-5-96
Hydraulic Cylinder - Stern Gate Hydraulic System.....	11-5-94
Hydraulic Directional Control Valve	3-T3-86

INDEX (Continued)

Volume - Chapter
- Paragraph
or Table

H (continued)

Hydraulic Filter - Hydraulic Tank - Anchor Winch	6-3-137.2
Hydraulic Filter and Piping - Anchor Winch.....	11-5-80
Hydraulic Motor	7-3-189
Hydraulic Power Unit - Centralized Hydraulic System	3-T3-79
Hydraulic Power Unit and Return.....	7-3-187
Hydraulic Pump - Anchor Winch.....	3-T3-58
Hydraulic Pump - Anchor Winch.....	6-3-139.1
Hydraulic Pump.....	11-5-86
Hydraulic Pump, Hoses, and Fittings	6-3-139
Hydraulic Pump.....	6-3-139.1
Hoses, Lines and Fittings	6-3-139.2
Hydraulic Reservoir - Anchor Winch	11-5-80
Hydraulic Reservoir - Hydrostarter.....	10-5-27
Hydraulic Reservoir - Ship's Hydraulic System.....	11-5-87
Hydraulic Reservoir Tank and Suction Filter	7-3-190
Hydraulic Starting System	2-2-21
Aft Engine Room - Preliminary Adjustments	2-2-24
- Shut Down	2-2-25
Anchor Winch Compartment - Preliminary Adjustments.....	2-2-26
- Shut Down	2-2-27
Forward Engine Room - Preliminary Adjustments.....	2-2-22
- Shut Down.....	2-2-23
Hydraulic Starting System Piping (Aft Engine Room).....	10-5-26
Hydraulic Starting System Piping (Forward Engine Room)	10-5-25
Hydraulic Starting Systems - Principles of Operation.....	1-1-87
Anchor Winch Compartment.....	1-1-88
Diesel Generator And Propulsion Engines	1-1-89
Hydraulic Steering Cylinder and Adjustable Links	3-T3-87
Hydraulic Systems - Principles of Operation.....	1-1-55
Hydraulic Tank - Anchor Winch	3-T3-57
Hydraulic Tank Assembly	6-3-137
Check Valve	6-3-137.5
Directional Valve - Pilot Operated.....	6-3-137.6
Directional Valve - Spring Centered Solenoid	6-3-137.9
Hydraulic Filter	6-3-137.2
Pilot Valve and Manifold.....	6-3-137.3
Pressure Control Valve.....	6-3-137.4
Pressure Reducing Valve	6-3-137.8
Relief Valve.....	6-3-137.7
Tank Assembly	6-3-137.1
Hydraulic Winch	11-5-100

INDEX (Continued)

Volume - Chapter
- Paragraph
or Table

H (continued)

Hydrostarter		
Cranking Speed Too Low		3-T3-32
Fluid Emerges Around Rubber Boot of Hand Pump.....		3-T3-40
Fluid Emerges from Ends of Starter Control		
Valve When Starter Is Operated.....		3-T3-41
Fluid Emerges from Reservoir Filler Cap		
When Starter Is Used		3-T3-39
Hand Pump Fails to Discharge Fluid		3-T3-35
High Pressure in System (3500 psi (24,133 kPa or above)		3-T3-38
Loss of Accumulator Precharge (Nitrogen)		3-T3-37
Loss of Fluid Pressure When Engine Is Not Running.....		3-T3-34
Loss of Fluid from Reservoir		3-T3-33
Loss or No Accumulator Pressure		3-T3-31
Starter Turns but Engine Does Not.....		3-T3-36
Low or High Exhaust Valve Opening Pressure		3-T3-30
Low Oil Pressure		3-T3-28
No Fuel or Insufficient Fuel		3-T3-25
Hydrostarter.....		10-5-21
Hydrostarter - Anchor Winch		7-3-176
Hydrostarter - Engine Driven Pump.....		10-5-23
Hydrostarter - Generator		5-3-101
Hydrostarter - Propulsion.....		4-3-46
Hydrostarter Filter - Anchor Winch		7-3-180.2
Hydrostarter Filter - Propulsion.....		4-3-52.2
Hydrostarter Hand Pump - Anchor Winch.....		7-3-179
Hydrostarter High Pressure Filter.....		5-3-107.4
Hydrostarter Piping - Anchor Winch		7-3-181
Hydrostarter Piping (Aft Engine Room) - Generator		5-3-106
Hydrostarter Piping (Aft Engine Room) - Propulsion.....		4-3-51
Hydrostarter Piping (Forward Engine Room) - Generator		5-3-105
Hydrostarter Piping (Forward Engine Room) -Propulsion		4-3-50
Hydrostarter Pump (Engine-Driven) - Anchor Winch		7-3-178
Hydrostarter Pump (Engine-Driven) - Generator		5-3-103
Hydrostarter Pump (Engine-Driven) - Propulsion.....		4-3-48
Hydrostarter Pump (Hand) - Generator		5-3-104
Hydrostarter Pump (Hand) - Propulsion		4-3-49
Hydrostarter Reservoir - Anchor Winch		7-3-180.1
Hydrostarter Reservoir - Generator		5-3-107.1
Hydrostarter Reservoir - Propulsion.....		4-3-52.1

INDEX (Continued)

Volume - Chapter
- Paragraph
or Table

H (continued)

Hydrostarter Reservoir and Filter - Anchor Winch	7-3-180
Hydrostarter Filter	7-3-180.2
Hydrostarter Reservoir	7-3-180.1
Hydrostarter Solenoid	7-3-180.3
Hydrostarter Reservoir, Filter, and Solenoids -	
Generator.....	5-3-107
Hydrostarter High Pressure Filter	5-3-107.4
Hydrostarter Reservoir	5-3-107.1
Hydrostarter Solenoid.....	5-3-107.3
Hydrostarter Suction Filter.....	5-3-107.2
Hydrostarter Reservoir, Filter, and Solenoids -	
Propulsion	4-3-52
Hydrostarter Filter	4-3-52.2
Hydrostarter Reservoir	4-3-52.1
Hydrostarter Solenoid.....	4-3-52.3
Hydrostarter Solenoid	10-5-24
Hydrostarter Solenoid - Anchor Winch	7-3-180.3
Hydrostarter Solenoid - Generator	5-3-107.3
Hydrostarter Solenoid - Propulsion.....	4-3-52.3
Hydrostarter Suction Filter	5-3-107.2

I

Idler Gear	10-5-19.2
Idler Gear and Bearing Assembly - Anchor Winch.....	6-3-166.3
Idler Gear and Bearing Assembly - Generator.....	5-3-91.3
Idler Gear Hole Spacer	10-5-19.3
Incandescent Bulkhead Fixture - Numbers 3532F6 and 3532F6R	5-3-111.1
Incandescent Bulkhead Fixture - Number 3541	5-3-111.2
Incandescent Ceiling Fixture.....	5-3-111.3
Incandescent Lighting Fixture - Symbol 98.1	5-3-112.1
Injector Controls - Anchor Winch	6-3-162
Injector Controls - Generator	5-3-87
Injector Controls - Propulsion.....	4-3-31
Installation of Separately Packed Components	3-3-3, 8-4-3
Instrument Panel - Anchor Winch	7-3-174
Instrument Panel - Generator	5-3-99
Instrument Panel - Propulsion.....	4-3-24

INDEX (Continued)

Volume - Chapter
- Paragraph
or Table

I (continued)

Interior Arrangements.....	1-1-22
Aft Engine Room.....	1-1-33
Air Conditioning Machinery Room	1-1-28
Anchor Winch Compartment.....	1-1-34
Bow Ramp Winch Compartment and Deck Locker.....	1-1-27
Crew and Transient Berthing.....	1-1-30
Engine Access Room	1-1-26
Equipment and Repair Parts Storage	1-1-29
Equipment and Repair Parts Storage - Ordnance	1-1-31
Fire Fighting Systems	1-1-37
Forward Engine Room.....	1-1-32
Galley	1-1-24
Pilot House.....	1-1-23
Propellers, Rudders and Keel Coolers.....	1-1-36
Steering Gear Compartment	1-1-35
Wash Room, Water Closet and Shower	1-1-25
Interior Communications.....	2-2-151
Communications (1JV and E).....	2-2-153
Horns (NH and 5U).....	1-2-154
Interior Communications Turn ON/OFF	2-2-152
Interior Communication System.....	9-4-47, 11-5-151
Amplifier/Loudspeaker.....	9-4-47.1
Cal I System Major Components	9-4-47.4
Loudhailer	9-4-47.3
Sound Powered Phones	9-4-47.2
Voice Tube.....	9-4-47.5
Interior Communication Systems	11-5-150
Alarm Switchboard	11-5-152
Amplifier/Loudspeaker.....	11-5-154
Interior Communication System	11-5-151
Loudhailer	11-5-155
Thermostat Switch and Magazine Alarm	11-5-153
Interior Communication Systems - Principles of Operation.....	1-1-84
Interior Communications Turn ON/OFF	2-2-152
Interlock Door Operated Switch	5-3-110.5
Intermediate Storage	7-3-222

K

Kort Nozzles, Rudders and Fences - Principles of Operation.....	1-1-45
--	--------

INDEX (Continued)

Volume - Chapter
- Paragraph
or Table

L

Lashing Gear	9-4-80
Level Wind 6	6-3-132
Level Wind Assembly 1	1-5-62
Life Boats	2-2-162, 2-2-212
Life Preservers	2-2-210
Life Rings 2	2-2-211
Life Saving Equipment	2-2-209
Life Boats.....	2-2-212
Life Preservers.....	2-2-210
Life Rings.....	2-2-212
Oxygen Breathing Apparatus.....	2-2-213
Pyrotechnic.....	2-2-214
Lifter Brackets and Supports.....	5-3-84
Lighting.....	2-2-126
Lighting Distribution Panels	5-3-109.1
Lighting Distribution Systems - Principles of Operation	1-1-51
Lights	5-3-111
Berth Light 5.....	5-3-111.8
Floodlight	5-3-111.4
Fluorescent Desk Lamp.....	5-3-111.5
General Purpose Fluorescent Fixture (1 Tube).....	5-3-111.7
General Purpose Fluorescent Fixture (2 Tube).....	5-3-111.6
Incandescent Bulkhead Fixture - Numbers 3532F6 and 3532F6R	5-3-111.1
Incandescent Bulkhead Fixture - Number 3541	5-3-111.2
Incandescent Ceiling Fixture - Number 3528F6.....	5-3-111.3
Limit Switches and Wire Rope Guards - Bow Ramp.....	6-3-123
Hand Crank Interlock Limit Switch.....	6-3-123.2
Slack Cable Interlock Limit Switch.....	6-3-123.1
Wire Rope Guard and Slack Cable Interlock Limit Switch Bracket.....	6-3-123.3
2-Line Alarm Panel.....	9-4-48.2
Liquid Foam	2-2-204
Liquid Solenoid Valve.....	9-4-36.1
List of Abbreviations	1-1-6
Local Controller Switches - Winch Compartment and Deck Locker - Bow Ramp.....	6-3-122.2
Location and Description of Major Components.....	1-1-9
Loss of Accumulator Precharge (Nitrogen) - Hydrostarter - Anchor Winch	3-T3-75
Loss of Accumulator Precharge (Nitrogen) - Hydrostarter	3-T3-37
Loss of Accumulator Precharge (Nitrogen) - Propulsion.....	3-T3-17

INDEX (Continued)

Volume - Chapter
- Paragraph
or Table

L (continued)

Loss of Fluid Pressure - Engine Not Running - Propulsion	3-T3-14
Loss of Fluid Pressure When Engine Is Not Running - Hydrostarter - Anchor Winch	3-T3-71
Loss of Fluid Pressure When Engine Is Not Running - Hydrostarter	3-T3-34
Loss of Fluid from Reservoir - Hydrostarter - Anchor Winch	3-T3-70
Loss of Fluid from Reservoir - Hydrostarter.....	3-T3-33
Loss of Fluid from Reservoir - Propulsion	3-T3-13
Loss or No Accumulator Pressure - Hydrostarter	3-T3-31
Loss or No Accumulator Pressure - Propulsion	3-T3-11
Loudhailer.....	11-5-155
Loudhailer.....	9-4-47.3
Low or High Exhaust Valve Opening Pressure - Anchor Winch Engine.....	3-T3-67
Low or High Exhaust Valve Opening Pressure - Hydrostarter	3-T3-30
Low or High Exhaust Valve Opening Pressure - Propulsion	3-T3-9
Lowering Bow Ramp - Emergency Procedures.....	2-2-191
- Local	2-2-56
- Remote.....	2-2-54
Low or No Accumulator Pressure - Anchor Winch Engine	3-T3-68
Low Oil Pressure - Anchor Winch Engine	3-T3-65
Low Oil Pressure - Hydrostarter	3-T3-28
Low Oil Pressure - Propulsion.....	3-T3-7
Lube Oil Cooler - Anchor Winch	6-3-149
Lube Oil Cooler - Generator	5-3-74
Lube Oil Distribution System - Anchor Winch.....	6-3-170
Lube Oil Distribution System - Generator	5-3-95
Lube Oil Distribution System - Propulsion	4-3-39
Lube Oil Filter.....	5-3-70.1
Lube Oil Filters, Hoses, and Housing - Anchor Winch	6-3-148
Oil Filter (By-pass) - Hoses and Housing.....	6-3-148.2
Oil Filter (Full Flow).....	6-3-148.1
Lube Oil Filters and Housing - Propulsion	4-3-16
Lube Oil Filters and Housing/Breather - Generator	5-3-73
Housing/Breather	5-3-73.2
Lube Oil Filter	5-3-73.1
Lube Oil Piping.....	11-5-163
Lube Oil Piping System	9-4-56
Lube Oil Pressure Relief Valve	4-3-36

INDEX (Continued)

Volume - Chapter
- Paragraph
or Table

L (continued)

Lube Oil Pressure Regulator - Anchor Winch.....	6-3-168.1
Lube Oil Pressure Regulator - Generator.....	5-3-93.1
Lube Oil Pressure Regulator - Propulsion.....	4-3-37
Lube Oil Pressure Regulator and By-Pass.....	5-3-93
Lube Oil Pressure Regulator.....	5-3-93.1
Oil By-pass Valve.....	5-3-93-2
Lube Oil Pressure Regulator and Oil By-Pass.....	6-3-168
Lube Oil Pressure Regulator.....	6-3-168.1
Oil By-pass Valve.....	6-3-168-2
Lube Oil Pressure Regulator and Relief Valve.....	10-5-17
Lube Oil Pump - Anchor Winch.....	11-5-78
Lube Oil Pump - Generator.....	10-5-42
Lube Oil Pump - Propulsion.....	10-5-16
Lube Oil Pump - Anchor Winch.....	6-3-169
Lube Oil Pump - Generator.....	5-3-94
Lube Oil Pump - Propulsion.....	4-3-38
Lube Oil Pump Controller.....	11-5-124
Lube Oil Pump Controller.....	8-4-10.4
Lube Oil Pump Motor.....	11-5-123
Lube Oil Pump Motor.....	8- 4-10.4
Lube Oil Pump.....	8-4-10.2
Lube Oil Pump Set.....	11-5-122
Lube Oil Pump Set.....	8-4-10.1
Lube Oil Transfer Pump.....	8-4-14
Lube Oil Transfer System.....	2-2-63
Lubricating Oil Cooler.....	4-3-17
Lubricating Oil Pressure Alarm Switch.....	5-3-65.4
Lubricating Oil Pressure Switch.....	4-3-9.5

M

Machine Gun, Ready Service Lockers and Grenade Lockers - Exterior Orientation.....	1-1-14
Machine Gun Tripod Mount.....	2-2-164
Machinery Cooling and Keel Coolers.....	9-4-55
Machinery and Keel Coolers.....	11-5-159
Magneto Assembly - Fire Pump (P-250).....	8-4-7.5
Magazine Sprinkler.....	2-2-81
Main and Flanking Rudders.....	11-5-110
Main Mast.....	2-2-65
Main Mast - Lowering.....	2-2-67
- Raising.....	2-2-66
Main Switchboard.....	10-5-29

INDEX (Continued)

Volume - Chapter
- Paragraph
or Table

M (continued)

Maintenance Forms, Records and Reports	1-1-2
Marine Gear	10-5-5
Marine Gear	3-T3-10
Marine Gear	4-3-8
Marine Gear Oil Lines.....	4-3-8.1
Marine Gear - Come Home	2-2-179
Marine Gear Oil Lines	4-3-8.1
Marine Gear - Principles of Operation.....	1-1-43
Mast	1-5-83
Mast	7-3-185
Mast Controls - Controls and Indicators	1-2-15
Mast Hydraulic Directional Control Valve.....	7-3-198
Mast Hydraulic Hoses, Fittings and Piping	7-3-199
Mast Hydraulic Ram 7	7-3-197
Mast Hydraulic System	3-T3-82
Mast Hydraulic System	11-5-95
Hose and Fittings	11-5-98
Hydraulic Controller and Flow Control Manifold.....	11-5-97
Hydraulic Cylinder	1-5-96
Master Controller Switches - Bow Ramp.....	6-3-122
Remote Controller Switch - Pilot House.....	6-3-122.1
Remote Controller Switch - Starboard Bow Ramp	6-3-122.2
Milk Dispenser	2-2-138
Milk Dispenser	9-4-40
Milk Dispenser	11-5-148
Miscellaneous Components on Cargo Deck - External Orientation	1-1-21
Miscellaneous Valves and Headers	9-4-36
Controller	9-4-36.8
Heat Interchanger.....	9-4-36.3
Liquid Solenoid Valve.....	9-4-36.1
Packless Valve.....	9-4-36.7
Receiver	9-4-36.2
Refrigerant Tubing	9-4-36.6
Thermometers.....	9-4-36.5
Water Regulating Valve	9-4-36.4
Mooring, Towing, Causeway Fittings And Lashing Gear - Exterior Orientation.....	1-1-12
Mooring and Towing Fittings.....	9-4-76
Motor Controller- Principles Of Operation	1-1-62
Motor- Hydraulic Cub Pump Unit.....	11-5-103
M-Type Relay- Fire Pump Controller	11-5-121.3
Muffler.....	10-5-15
Muffler, Exhaust- Fire Pump (PE-250).....	8-4-7.6A
Muffler- Propulsion 4-3-29	

INDEX (Continued)

Volume - Chapter
- Paragraph
or Table

N

Navigation Horn.....	9-4-49.2
Navigation Light- Anchor and Boom	5-3-113.7
Navigation Light- Blinker	5-3-113.9
Navigation Light- Masthead	5-3-113.4
Navigation Light- Port	5-3-113.2
Navigation Light- Starboard	5-3-113.1
Navigation Light- Stern	5-3-113.5
Navigation Light- Towing	5-3-113.3
Navigation Lights.....	2-2-129
Navigation System- Principles of Operation.....	1-1-85
Navigational Light Panel.....	5-3-114
Navigational- Searchlight	2-2-149
Night Vision Lights.....	2-2-155
No Fuel or Insufficient Fuel - Anchor Winch Engine.....	3-T3-62
No Fuel or Insufficient Fuel - Hydrostarter.....	3-T3-25
No Fuel or Insufficient Fuel - Propulsion	3-T3-4
Non-follow-up Steering	2-2-60
Nomenclature Cross Reference.....	1-1-5
Normal Operation - Sewage System	2-2-106
Normal Steering	2-2-59

O

Oil Breather	4-32.2
Oil By-pass Valve - Anchor Winch	6-3-168.2
Oil By-pass Valve - Generator	5-3-93.2
Oil Cooler and Lines.....	4-3-17
Oil Filler- Anchor Winch	6-3-163.2
Oil Filler - Generator	5-3-88.2
Oil Filter (By-pass) - Hoses and Housing.....	6-3-148.2
Oil Filter (Full Flow).....	6-3-148.1
Oil Pan and Dipstick - Anchor Winch	6-3-163.1
Oil Pan and Dipstick - Generator	5-3-88.1
Oil Pan and Dipstick - Propulsion.....	4-3-35
Oil Pan, Dipstick and Oil Filler - Anchor Winch	6-3-163
Oil Filler.....	6-3-163.2
Oil Pan and Dipstick.....	6-3-163.1
Oil Pan, Dipstick and Oil Filler - Generator.....	5-3-88
Oil Filler.....	5-3-88.2
Oil Pan and Dipstick.....	5-3-88.1

INDEX (Continued)

Volume - Chapter
- Paragraph
or Table

O (continued)

Oil/Water Separation System	11-5-158
Oil/Water Separation System	2-2-100
Bilge Draining.....	2-2-102
Emptying Holding Tank.....	2-2-104
Pre-start Adjustments.....	2-2-101
Used Engine Oils	2-2-103
Oil/Water Separator.....	11-5-169
Oil/Water Separator.....	9-4-51
Oil/Water Separator Piping.....	9-4-63
Oil/Water Separator System Piping - Principles of Operation.....	1-1-79
Operator's Controls and Indicators.....	1-2-1
Aft Engine Room.....	1-2-12
Air Conditioning Machinery Room	1-2-7
Anchor Winch Controls.....	1-2-17
Anchor Winch Room	1-2-13
Crew and Transient Berthing.....	1-2-9
Emergency Shutdown	1-2-16
Engine Room Access	1-2-5
Equipment and Repair Parts Stores.....	1-2-8
Forward Engine Room.....	1-2-11
Galley and Mess Room	1-2-3
Mast Controls.....	1-2-1 5
Ordnance, Equipment and Repair Parts Stores	1-2-10
Pilot House.....	1-2-2
Ramp Handling Machinery Compartment and Bow Ramp.....	1-2-6
Steering Gear Compartment	1-2-14
Stern Gate Controls.....	1-2-18
Washroom, Water Closet and Shower.....	1-2-4
Operation Under Unusual Conditions.....	2-2-173
Damage Control Procedures	2-2-194
Emergency Procedures	2-2-174
Life Saving Equipment.....	2-2-200
Operation Under Usual Conditions.....	2-2-20
Air Conditioning System.....	2-2-109
Alarm System	2-2-114
Anchor Winch "A" Frame	2-2-47
Bow Ramp Winch	2-2-53
Central Hydraulic System - Including Main Mast and Stern Gate.....	2-2-64
Fire, Bilge and Ballast System.....	2-2-76
Flushing System.....	2-2-108
Fresh Water Pressure System.....	2-2-74

INDEX (Continued)

Volume - Chapter
- Paragraph
or Table

O (continued)

Operation Under Usual Conditions (Continued)

Galley and Mess Equipment.....	2-2-133
Generating System	2-2-35
Halon System.....	2-2-119
Heaters	2-2-125
Hydraulic Starting System.....	2-2-21
Interior Communications	2-2-151
Lighting.....	2-2-126
Lube Oil Transfer System.....	2-2-63
Night Vision Lights	2-2-155
Oil/Water Separator System.....	2-2-100
Pilot House Equipment.....	2-2-127
Preparation for Movement.....	2-2-156
Propulsion System	2-2-29
Sewage System	2-2-105
Stand-by Lube Oil System.....	2-2-71
Steering	2-2-58
Tank Level Indicating System	2-2-75
Ventilating Fans	2-2-124
Wash Room Water Closet, and Shower Equipment.....	2-2-142
Ordnance - Equipment and Repair Stores - Controls and Indicators.....	2-2-10
Over-board Discharge - Sewage System	2-2-107
Overspeed Governor - Anchor Winch	6-3-154
Overspeed Governor - Generator	5-3-79
Oxygen Breathing Apparatus.....	2-2-213

P

Packless Valve.....	9-4-36.7
Panel Boards- Power Distribution and Shore Power Connection Box	5-3-61
Paralleling Generator.....	2-2-42
Peak Ballast Tank Filling	2-2-83
Pilot House- Controls and Indicators.....	1-2-2
Pilot House Equipment	2-2-127
Battery Charger/Exhaust.....	2-2-131
Darken Ship.....	2-2-130
Electronic Devices.....	2-2-132
Navigation Lights.....	2-2-129
Windshield Wiper	2-2-128

INDEX (Continued)

Volume - Chapter
- Paragraph
or Table

P (continued)

Pilot House- Interior Arrangements	1-1-23
Pilot Valve and Manifold - Hydraulic Tank - Anchor Winch	6-3-137.3
Pipe Hangers.....	9-4-53
Piping - Sewage System	8-4-22
Piping Systems.....	9-4-52, 11-5-159
Deck Fittings.....	9-4-65, 11-5-170
Diesel Oil Cooling Piping.....	9-4-59, 11-5-166
Diesel Oil Piping.....	9-4-58, 11-5-165
Diesel Oil Stowage Tank Piping	9-4-57, 11-5-164
Duplex Strainers.....	9-4-60
Engine Exhaust.....	9-4-62
Engine Exhaust Piping.....	11-5-167
Exhaust Pipe Hangers.....	11-5-160
Fire, Ballast and Bilge Piping	11-5-161
Fire, Bilge and Ballast Piping	9-4-54
Fresh and Flush Water Piping.....	9-4-64, 11-5-168
Hot Water Heater.....	11-5-171
Lube Oil Piping.....	9-4-56, 11-5-163
Machinery and Keel Coolers.....	11-5-162
Machinery Cooling and Keel Coolers.....	9-4-55
Oil Water Separator Piping System.....	9-4-63, 11-5-169
Pipe Hangers	9-4-53
Sewage System	9-4-15
Piping Systems- Principles of Operation	1-1-66
Piston- Anchor Winch	7-3-171.1
Piston- Generator	5-6-96.1
Piston- Propulsion	4-3-40.1
Piston, Connecting Rods and Cylinder Liners - Anchor Winch	7-3-171
Connecting Rod Bearings.....	7-3-171.3
Connecting Rods.....	7-3-171.2
Cylinder Liner.....	7-3-171.4
Piston.....	7-3-171.1
Piston, Connecting Rods and Cylinder Liners - Generator.....	5-3-96
Connecting Rod Bearings.....	5-3-96.3
Connecting Rods.....	5-3-96.2
Cylinder Liner.....	5-3-96.4
Piston.....	5-3-96.1

INDEX (Continued)

Volume - Chapter
- Paragraph
or Table

P (continued)

Pistons, Connecting Rods and Liners.....	4-3-40
Connecting Rod Bearings.....	4-3-40.3
Connecting Rods.....	4-3-40.2
Cylinder Liner.....	4-3-40.4
Piston.....	4-3-40.1
Plumbing and Deck Drains.....	9-4-68
Port Engine - Stand-by Lube Oil System.....	2-2-73
Port Line Shaft.....	4-3-54
Portable Air Compressor.....	9-4-73
Portable Davit.....	6-3-127,10-5-56
Portable Extinguishers.....	2-2-198
Portable Fire Pump.....	2-2-199
Applications.....	2-2-202
Preliminary Adjustments (Fuel and Assembly).....	2-2-200
Starting.....	2-2-201
Stopping and Storage.....	2-2-203
Portable Fire Pump (P-250).....	8-4-7
Carburetor Assembly.....	8-4-7.2
Carburetor Linkage, Control Panel and Manifold.....	8-4-7.3
Crankshaft and Piston.....	8-4-7.7
Foot Valve Assembly.....	8-4-7.8
Fuel Tank Assembly.....	8-4-7.4
Magneto Assembly.....	8-4-7.5
Power Head and Receiver Assembly.....	8-4-7.6
Pressure Regulating and Operating Cylinder.....	8-4-7.9
Priming Pump and Gear Housing.....	8-4-7.11
Pump and Water Outlet Valve.....	8-4-7.10
Starter Assembly.....	8-4-7.1
Portable Fire Pump (PE-250).....	8-4-7A
Battery.....	8-4-7.8A
Carburetor.....	8-4-7.7A
Discharge Valve.....	8-4-7.3A
Engine.....	8-4-7.10A
Engine Control Panel.....	8-4-7.1A
Gage Panel.....	8-4-7.2A
Muffler, Exhaust.....	8-4-7.6A
Priming Pump.....	8-4-7.5A
Pump.....	8-4-7.4A
Retractable Starter.....	8-4-7.11A
Solenoid and Electric Starter.....	8-4-7.9A
Portable Lantern.....	5-3-112.3

INDEX (Continued)

Volume - Chapter
- Paragraph
or Table

P (continued)

Power Distribution Panel Boards.....	10-5-31
Power Distribution Panel Boards.....	5-3-61
Power Distribution Panel	5-3-61.1
Shore Power Distribution Box.....	5-3-61.2
Power Distribution Panel.....	5-3-61.1
Power Distribution System - Principles of Operation	1-1-50
Power Head and Receiver Assembly - Fire Pump (P-250)	8-4-7.6
Preliminary Adjustments - Centralized Hydraulic System.....	2-2-65
Preliminary Adjustments - Generating System.....	2-2-37
Preliminary Adjustments - Portable Fire Pump	2-2- 200
Preliminary Servicing of Equipment.....	3-3-2, 8-4-2
Preparation for Movement	2-2-156
Docking.....	2-2-158
Lifting.....	2-2-157
Pre-Start Adjustments - Oil/Water Separator System	2-2-101
Pressure Control Valves - Hydraulic Tank - Anchor Winch.....	3-T3-54
Pressure Control Valve - Hydraulic Tank - Anchor Winch.....	6-3-137.4
Pressure Reducing Valves - Hydraulic Tank - Anchor Winch.....	3-T3-55
Pressure Reducing Valve - Hydraulic Tank - Anchor Winch.....	6-3-137.8
Pressure Regulating and Operating Cylinder - Fire Pump (P-250).....	8-4-7.9
Preventive Maintenance Checks and Services	1-2-19
Priming Pump- Fire Pump (PE-250)	8-4-7.5A
Priming Pump and Gear Housing - Fire Pump (P-250).....	8-4-7.11
Principles of Operation	
"A" Frame 1	1-1-57
Anchor Winch Engine.....	1-1-53
Anchor Winch System.....	1-1-52
"A" Frame 1--5	1-1-57
Anchor Winch	1-1-56
Anchor Winch Engine.....	1-1-53
Hydraulic System 1-	1-1-55
Torque Converter	1-1-54
Anchor Winch	1-1-56
Ballast System Piping.....	1-1-77
Bilge System Piping.....	1-1-76
Bow Ramp Winch Systems.....	1-1-58

INDEX (Continued)

Volume - Chapter
- Paragraph
or Table

P (continued)

Principles of Operation (Continued)	
Centralized Hydraulic System	1-1-81
Communication Systems.....	1-1-86
Cub Hydraulic Pump Unit.....	1-1-60
Deck and Sanitary Drain Piping System.....	1-1-73
Diesel Generator and Propulsion Engine - Hydraulic Starting System.....	1-1-89
Engine Cooling Water System.....	1-1-67
Engine Lube Oil Transfer System.....	1-1-70
Exhaust Piping System	1-1-68
Fire System Piping.....	1-1-75
Flanking Rudder Limit Switch Assembly.....	1-1-63
Flushing System Piping.....	1-1-78
Fresh Water System Piping.....	1-1-72
Fuel System.....	1-1-69
Generator.....	1-1-48
Generator Engine.....	1-1-47
Halon Systems.....	1-1-82
Heading Selector.....	1-1-61
Heating, Ventilation and Air Conditioning Systems.....	1-1-80
Hydraulic Starting Systems.....	1-1-87
Anchor Winch Compartment.....	1-1-88
Diesel Generator and Propulsion Engines.....	1-1-89
Hydraulic Systems.....	1-1-55
Interior Communication Systems.....	1-1-84
Kort Nozzles, Rudders and Fences.....	1-1-45
Lighting Distribution Systems.....	1-1-51
Marine Gear.....	1-1-43
Motor Controller.....	1-1-62
Navigation System.....	1-1-85
Oil/Water Separator System Piping.....	1-1-79
Piping Systems.....	1-1-66
Power Distribution System.....	1-1-50
Propeller Shafts and Miscellaneous Components.....	1-1-44
Propulsion Engine.....	1-1-42
Propulsion Systems.....	1-1-41
Kort Nozzles, Rudders and Fences.....	1-1-45
Marine Gear.....	1-1-43
Propeller Shaft and Miscellaneous Components.....	1-1-44
Propulsion Engine.....	1-1-42
Rudder Angle Indicator and Transmitter.....	1-1-65
Sewage System Piping.....	1-1-74

INDEX (Continued)

Volume- Chapter
- Paragraph
or Table

P (continued)

Principles of Operation (Continued)	
Ship's Piping System.....	1-1-66
Ballast System.....	1-1-77
Bilge System.....	1-1-76
Centralized Hydraulic System.....	1-1-81
Deck and Sanitary Drain Piping System.....	1-1-73
Engine Cooling Water System.....	1-1-67
Engine Lube Oil Transfer System.....	1-1-70
Exhaust Piping System.....	1-1-68
Fire System.....	1-1-75
Flushing System m.....	1-1-78
Fresh Water System.....	1-1-72
Fuel System.....	1-1-69
Halon System m.....	1-1-82
Heating, Ventilation and Air Conditioning Systems.....	1-1-80
Oil/Water Separator System.....	1-1-79
Sewage System.....	1-1-74
Standby Lube Oil Pump.....	1-1-71
Tank Level Indicating System.....	1-1-83
Ship's Service Generating Systems.....	1-1-46
Generator.....	1-1-48
Generator Engine.....	1-1-47
Lighting Distribution.....	1-1-51
Power Distribution.....	1-1-50
Switchboard.....	1-1-49
Ship's Steering Systems.....	1-1-59
Cub Hydraulic Pump Unit.....	1-1-60
Flanking Rudder Limit Switch Assembly.....	1-1-63
Heading Selector.....	1-1-61
Motor Controller.....	1-1-62
Rudder Angle Indicator and Transmitter.....	1-1-65
Steering Rudder Repeatback Unit.....	1-1-64
Standby Lube Oil Pump.....	1-1-71
Steering Rudder Repeatback Unit.....	1-1-64
Switchboard.....	1-1-49
Tank Level Indicating System.....	1-1-83
Technical Principles of Operation- General.....	1-1-40
Anchor Winch Systems.....	1-1-52
Bow Ramp Systems.....	1-1-58
Communication Systems.....	1-1-86
Hydraulic Starting Systems.....	1-1-87

INDEX (Continued)

Volume - Chapter
- Paragraph
or Table

P (continued)

Principles of Operation (Continued)	
Technical Principles of Operation.....	- General
(Continued)	
Interior Communication Systems.....	1-1-84
Navigation Systems.....	1-1-85
Piping Systems.....	1-1-66
Propulsion Systems.....	1-1-41
Kort Nozzles, Rudders and Fences.....	1-1-45
Marine Gear.....	1-1-43
Propeller Shafts and Miscellaneous Components.....	1-1-44
Propulsion Engine.....	1-1-42
Ship's Service Generating System.....	1-1-46
Generator.....	1-1-48
Generator Engine.....	1-1-47
Lighting Distribution.....	1-1-51
Power Distribution.....	1-1-50
Switchboard.....	1-1-49
Steering Systems.....	1-1-59
Torque Converter.....	1-1-54
Propellers, Rudders and Keel Coolers- Interior	
Arrangement.....	1-1-36
Propeller Shaft.....	4-3-53
Propeller Shaft and Bearings.....	11-6-1
Propeller Shafts and Miscellaneous Components -	
Principles of Operation.....	1-1-44
Propulsion Engine	
Abnormal Engine Coolant Operating Temperature.....	3-T3-8
Abnormal Engine Operation.....	3-T3-3
Cold Weather - Local Starting.....	2-2-31
Emergency Start.....	2-2-178
Emergency Stop.....	2-2-176
Excessive Crankcase Pressure.....	3-T3-6
Exhaust Smoke Analysis.....	3-T3-1
Hard Starting.....	3-T3-2
High Lubricating Oil Consumption.....	3-T3-5
Cranking Speed Too Low.....	3-T3-12
Fluid Emerges Around Rubber Boot of Hand Pump.....	3-T3-20
Fluid Emerges from Ends of Starter Control	
Valve When Starter is Operated.....	3-T3-21
Fluid Emerges from the Reservoir Filler Cap When	
Starter Is Used.....	3-T3-19
Hand Pump Fails to Discharge Fluid.....	3-T3-15

INDEX (Continued)

Volume - Chapter
- Paragraph
or Table

P (continued)

Propulsion Engine (Continued)

High Lubricating Oil Consumption (Continued)	
High Pressure in System (3500 psi (24,133 kPa) or above).....	3-T3-18
Loss of Accumulator Precharge (Nitrogen).....	3-T3-17
Loss of Fluid Pressure - Engine Not Running.....	3-T3-14
Loss of Fluid from Reservoir.....	3-T3-13
Loss or No Accumulator Pressure.....	3-T3-11
Starter Turns but Engine Does Not.....	3-T3-16
Low or High Exhaust Valve Opening Pressure.....	3-T3-9
Low Oil Pressure.....	3-T3-7
No Fuel or Insufficient Fuel.....	3-T3-4
Local Stop.....	2-2-32
Principles of Operation.....	1-1-42
Remote Starting.....	2-2-33
Remote Stop.....	2-2-34
Reset After Emergency Stop.....	2-2-177
Warm Weather - Local Starting.....	2-2-30

Propulsion Engine Maintenance Instructions.....

Accumulator.....	4-3-47
Air Intake.....	4-3-11
Balance Weight Cover and Accessory Drive.....	4-3-26
Blower a h.....	4-3-12
Crankshaft.....	4-3-42
Crankshaft Bearings.....	4-3-41
Crankshaft Pulley and Vibration Dampener.....	4-3-25
Crankshaft Seals.....	4-3-43
Cylinder Block k.....	4-3-44
Cylinder Head d.....	4-3-34
Engine Supports Lifter Brackets/Crankshaft Front Cover.....	4-3-27
Engine/Transmission Controls.....	4-3-9
Exhaust Manifold and Fittings.....	4-3-28
Flywheel and Housing Oil Breather.....	4-3-32
Fresh Water Pump.....	4-3-18
Fuel Filter, Strainer and Fuel Lines.....	4-3-14
Fuel Injector.....	4-3-15
Fuel Pump.....	4-3-13
Governor.....	4-3-10
Heat Exchanger Tank.....	9-3-19
Hydrostarter.....	4-3-46
Hydrostarter Piping (Aft Engine Room).....	4-3-51
Hydrostarter Piping (Forward Engine Room).....	4-3-50

INDEX (Continued)

Volume - Chapter
- Paragraph
or Table

P (continued)

Propulsion Engine Maintenance Instructions (Continued)	
Hydrostarter Pump (Engine-Driven).....	4-3-48
Hydrostarter Pump (Hand).....	4-3-49
Hydrostarter Reservoir, Filter, Solenoids.....	4-3-52
Injector Controls.....	4-3-31
Instrument Panel.....	4-3-24
Lube Oil Distribution System.....	4-3-39
Lube Oil Filters and Housing.....	4-3-16
Lube Oil Pump.....	4-3-38
Lube Oil Regulator.....	4-3-37
Lube Oil Relief Valve.....	4-3-36
Marine Gear.....	4-3-8
Muffler.....	4-3-29
Oil Cooler and Liners.....	4-3-17
Oil Pan & Dipstick.....	4-3-35
Pistons, Connecting Rods and Liners.....	4-3-40
Port Line Shaft.....	4-3-54
Propeller Shaft.....	4-3-53
Rocker Arm Cover.....	4-3-30
Shaft Inflatable Seal.....	4-3-55
Shaft Lock.....	4-3-57
Shaft Seals- Preformed.....	4-3-56
Starting Aid.....	4-3-45
Tachometer Drive.....	4-3-23
Thermostat and Housing.....	4-3-22
Valve Operating Mechanism.....	4-3-33
Water Connections.....	4-3-20
Water Manifold.....	4-3-21
Propulsion Engine and Marine Gear.....	10-5-3
Accumulator.....	10-5-22
Balance Weight Cover and Accessory Drive.....	10-5-13
Blower.....	10-5-8
Camshaft and Gear Train.....	10-5-19
Cylinder Block.....	10-5-20
Engine Supports, Lifter Brackets and Crankshaft Front Cover.....	10-5-14
Engine and Transmission Controls.....	1-5-6
Expansion Tank.....	10-5-10
Flywheel and Housing.....	10-5-18
Fuel Injector.....	10-5-9
Hydrostarter.....	10-5-21
Hydrostarter Piping (Aft Engine Room).....	10-5-26
Hydrostarter Piping (Forward Engine Room).....	10-5-25

INDEX (Continued)

Volume - Chapter
- Paragraph
or Table

P(continued)

Propulsion Engine and Marine Gear (Continued)	
Hydrostarter Pump (Engine Driven).....	10-5-23
Hydrostarter Solenoid.....	10-5-24
Lube Oil Pressure Regulator and Relief Valve.....	10-5-17
Lube Oil Pump.....	10-5-16
Marine Gear.....	10-5-5
Muffler.....	10-5-15
Propulsion/Marine Gear - Removal and Run-In Instructions.....	10-5-4
Reservoirs and Filters.....	10-5-27
Thermostat and Housing.....	10-5-12
Variable Speed Mechanical Governor.....	10-5-7
Water Manifold.....	10-5-11
Propulsion Engine/Marine Gear- Removal and Run-In Instructions.....	10-5-4
Propulsion System.....	2-2-29
Propulsion Engine - Cold Weather- Local Starting.....	2-2-31
- Local Stop.....	2-2-32
- Remote Starting.....	2-2-33
- Remote Stop.....	2-2-34
- Warm Weather- Local Starting.....	2-2-30
Propulsion System - Emergency Procedures.....	2-2-175
Marine Gear - Come Home.....	2-2-179
Propulsion Engine - Emergency Start.....	2-2-178
- Emergency Stop.....	2-2-176
- Reset After Emergency Stop.....	2-2-177
Propulsion Systems - Principles of Operation.....	1-1-41
Kort Nozzles, Rudders and Fences.....	1-1-45
Marine Gear.....	1-1-43
Propeller Shaft and Miscellaneous Components.....	1-1-44
Propulsion Engine.....	1-1-42
Pump- Fire Pump (PE-250).....	8-4-7.4A
Pump- Hydraulic Cub Pump Unit.....	11-5-105
Pump Sets.....	8-4-6, 11-5-118
Air Conditioning Water Circulation Pump Controller.....	11-5-128
Air Conditioning Water Circulation Pump Motor.....	11-5-127
Air Conditioner Water Circulation Pump Set.....	8-4-12
Bilge Pump.....	8-4-9
Diesel Oil Cooling Pump Motor.....	11-5-129
Diesel Oil Cooling Pump Set.....	8-4-13
Fresh Water Pump.....	8-4-11

INDEX (Continued)

Volume - Chapter
- Paragraph
or Table

P (continued)

Pump Sets (Continued)

Fire Pump.....	8-4-8, 11-5-119
Fire Pump Controller.....	11-5-121
Fire Pump Motor.....	11-5-120
Fresh Water Pump Controller.....	11-5-126
Fresh Water Pump Motor.....	11-5-125
Lube Oil Pump Controller.....	11-5-124
Lube Oil Pump Motor.....	11-5-123
Lube Oil Pump Set.....	11-5-122
Lube Oil Pump Set (Stand-by).....	8-4-10
Lube Oil Transfer Pump.....	8-4-14
Portable Fire Pump Set (P-250).....	8-4-7
Portable Fire Pump Set (PE-250).....	8-4-7A
Pump and Water Outlet Valve - Fire Pump (P-250).....	8-4-7.10
Pushbutton Switch.....	7-3-193,11-5-90
Pyrotechic.....	2-2-214

R

Radar Mast.....	2-2-159
Radio and Radar Communication Systems.....	11-5-156
Raising Bow Ramp - Emergency Procedures.....	2-2-192
- Local.....	2-2-57
- Remote.....	2-2-55
Ramp Handling Machinery Compartment and Bow Ramp - Controls and Indicators.....	1-2-6
Reactivation from Storage.....	7-3-223
Reactivation- Halon System.....	2-2-122
Ready Service Locker.....	2-2-165
Receiver.....	9-4-36.2
Recirculating Fan Controller.....	11-5-138
Recirculating Fan Motor.....	11-5-139
Rectifier 24 VDC.....	5-3-108
Rectifier - 24 VDC.....	3-T3-44
Refrigerator/Freezer.....	2-2-139, 9-4-38
Refrigerator/Freezer.....	11-5-147
Refrigerant Tubing.....	9-4-36 .6
Relay Operated Lantern.....	5-3-112.2
Relief Valve - Hydraulic Tank - Anchor Winch.....	6-3-137.7
Remote Controller Switch- Pilothouse- Bow Ramp.....	6-3-122.1

INDEX (Continued)

Volume - Chapter
- Paragraph
or Table

R (continued)

Remote Magnetic Heading Compass (RHMS)	7-3-217
Remote Magnetic Heading Compass.....	11-5-116,11-6-4
Remote Magnetic Heading System.....	3-T3-91
Remote Operation - Generator #1.....	2-2-40
Remote Operation - Generator #2.....	2-2-42
Remote Operation and Payout - Anchor Winch.....	2-2-50
Reporting Equipment Improvement Recommendations (EIR)	1-1-4
Reservoir, Tank and Strainer - Hydraulic Cub Pump Unit.....	11-5-107
Reset After Emergency Stop - Anchor Winch Engine.....	2-2-186
- Generator Engine.....	2-2-182
- Propulsion Engine.....	2-2-177
Retractable Starter- Fire Pump (PE-250)	8-4-7.11A
Rocker Arm Cover - Anchor Winch	6-3-161
Rocker Arm Cover - Generator	5-3-86
Rudder Angle Indicator	7-3-212, 11-5-111
Rudder Angle Indicator and Repeatback Transmitter	3-T3-88
Rudder Angle Indicator and Transmitter - Principles of Operation.....	1-1-65
Rudder Angle Transmitter.....	7-3-213,11-5-112
Rudders - Main and Flanking.....	11-5-110
Running Light Control Panel	10-5-46
Running Lights, Peloris, Masts, Flags and Services - Exterior Orientation	1-1-15
Running, Signal and Anchor Lights	5-3-113
Navigation Light - Anchor and Boom	5-3-113.7
Navigation Light - Blinker	5-3-113.9
Navigation Light - Masthead.....	5-3-113.4
Navigation Light - Port	5-3-113.2
Navigation Light - Starboard.....	5-3-113.1
Navigation Light - Stern	5-3-113.5
Navigation Light - Towing.....	5-3-113.3
Signal Light - Manoverboard.....	5-3-113.8
Signal Light - Task	5-3-113.6
Wake Light.....	5-3-113.10

INDEX (Continued)

Volume - Chapter
- Paragraph
or Table

S

Salvage Pump.....	2-2-207
Sanitizing Sink Heater	9-4-43
Sanitizing Sink Heater	2-2-141
Scope- General Information	1-1-1
Searchlight	2-2-167
Searchlight	9-4-79
Drum Assembly.....	9-4-79.4
Hood Assembly.....	9-4-79.2
Mounting and Yoke Assembly	9-4-79.1
Shutter Assembly	9-4-79.3
Searchlight- Navigational	2-2-149
- Turn ON/OFF	2-2-147
Sea Water Cooling Pump.....	2-2-110
Sewage Discharge Pump.....	8-4-19
Sewage Discharge Pump Motor	8-4-19.2
Sewage Discharge Pump	8-4-19.1
Sewage Sanitary Drain Piping	11-5-135
Sewage System.....	11-5-130
Flush Water Pump Motor	11-5-133
Sewage Discharge Pump.....	11-5-132
Sewage Sanitary Drain Piping.....	11-5-135
Sewage System Discharge Piping.....	11-5-134
Sewage Tank.....	11-5-136
Vacuum Pump	11-5-131
Sewage System.....	2-2-105,8-4-15
Controls and Indicators.....	8-4-21
Discharge Pump.....	8-4-19
Flush Water Pump	8-4-20
Holding Tank.....	8-4-23
Normal Operation.....	2-2-102
Over-board Discharge Holding Tank	2-2-103
Piping.....	8-4-22
Sewage System Vacuum Pump	8-4-18
Sewage Tank Flushing.....	2-2-84
Urinal	8-4-17
Water Closet.....	8-4-16
Sewage System Discharge Pump.....	11-5-132
Sewage System Discharge Piping	11-5-134
Sewage System Piping.....	8-4-22
Collection Tank Hoses and Gaskets	8-4-22.4
Discharge Piping.....	8-4-22.2
Drain Piping	8-4-22.3
Vent Piping	8-4-22.1

INDEX (Continued)

Volume - Chapter
- Paragraph
or Table

S (continued)

Sewage System Piping- Principles Of Operation	1-1-74
Sewage System Vacuum Pump.....	8-4-18
Vacuum Pump Motor	8-4-18.2
Vacuum Pump	8-4-18.1
Sewage Tank Flushing	2-2-84
Sewage Tank Flushing Shutdown	2-2-85
Sewage Tank.....	11-5-136
Shaft Inflatable Seal	4-3-55
Shaft Lock k	4-3-57
Shaft Seals.....	11-6-2
Shaft Seals.....	4-3-56
Ship's Course Indicator.....	3-T3-92
Ship's Course Indicator.....	7-3-219
Ship's Course Indicator.....	11-5-117
Ships Course Indicator and Peloris.....	2-2-168
Ship's Hydraulic System	11-5-84
Controller.....	11-5-88
Electric Motor.....	11-5-85
Gages	11-5-89
Hydraulic Pump.....	11-5-86
Hydraulic Reservoir.....	11-5-87
Push Button Switch	11-5-90
Ship's Piping System - Principles of Operation.....	1-1-66
Ballast System	1-1-77
Bilge System.....	1-1-76
Centralized Hydraulic System	1-1-81
Deck and Sanitary Drain Piping System.....	1-1-73
Engine Cooling Water System.....	1-1-67
Engine Lube Oil Transfer System.....	1-1-70
Exhaust Piping System	1-1-68
Fire System.....	1-1-75
Flushing System.....	1-1-78
Fresh Water System	1-1-72
Fuel System.....	1-1-69
Halon System.....	1-1-82
Heating, Ventilation and Air Conditioning Systems	1-1-80
Oil/Water Separator System.....	1-1-79
Sewage System	1-1-74
Standby Lube Oil Pump	1-1-71
Tank Level Indicating System	1-1-83

INDEX (Continued)

S (continued)

Volume - Chapter
- Paragraph
or Table

Ship's Service Generating Systems- Principles of Operation	1-1-46
Generator	1-1-48
Generator Engine	1-1-47
Lighting Distribution	1-1-51
Power Distribution.....	1-1-50
Switchboard.....	1-1-49
Ship's Steering Systems- Principles of Operation	1-1-59
Cub Hydraulic Pump Unit	1-1-60
Flanking Rudder Limit Switch Assembly	1-1-63
Heading Selector.....	1-1-61
Motor Controller.....	1-1-62
Rudder Angle Indicator And Transmitter	1-1-65
Steering Rudder Repeatback Unit.....	1-1-64
Shore Power.....	2-2-36
Shore Power Distribution Box	5-3-61.2
Shut-down Solenoid.....	5-3-65.2
Signal Light - Manoverboard.....	5-3-113.8
Signal Light - Task	5-3-113.6
Signalling Searchlight.....	2-2-146
Hood Assembly	2-2-150
Searchlight - Navigational.....	2-2-149
Searchlight Turn ON/OFF.....	2-2-147 4
Signalling.....	2-2-148
Simplex Strainer.....	9-4-54.3
Simplex Strainer.....	8-4-8.5
Slack Cable Interlock Limit Switch.....	6-3-123.1
Slack Puller- Anchor Winch	3-T3-49
Slack Puller	6-3-134
Slack Puller and Motor.....	10-5-64
Smoke Detector.....	9-4-46.3
Solenoid and Electric Starter- Fire Pump (PE-250)	8-4-7.9A
Sound Powered Phones.....	9-4-47.'2
Speed Reducer- Bow Ramp	6-3-119
Speed Reducer.....	10-5-50
Spotlight	2-738.1
Spotlight Turn ON/OFF.....	2-738.1
Spotlight Operation.....	2-738.3
Stanchions and Railings	9-4-71
Stand-by Lube Oil Pump.....	8-4-10
Lube Oil Pump Controller	8-4-10.4
Lube Oil Pump Motor.....	8-4-10.3
Lube Oil Pump.....	8-4-10.2
Lube Oil Pump Set	8-4-10.1
Stand-by Lube Oil Pump - Principles of Operation	1-1-71

INDEX (Continued)

Volume - Chapter
- Paragraph
or Table

S (continued)

Stand-by Lube Oil System	2-2-71
Stand-by Lube Oil System- Port Engine	2-2-73
- Starboard Engine.....	2-2-72
Starboard Engine - Stand-by Lube Oil System	2-2-72
Starter Assembly Fire Pump (P-250)	8-4-7.11
Starter (NEMA, Size 3, 3 Pole Reversing)- Fire Pump Controller	11-5-121.2
Starter Turns but Engine Does Not - Hydrostarter - Anchor Winch	3-T3-73
Starter Turns but Engine Does Not - Hydrostarter	3-T3-36
Starter Turns but Engine Does Not - Propulsion	3-T3-16
Starting Aid- Anchor Winch	7-3-175
Starting Aid- Generator	5-3-100
Starting Aid- Propulsion	4-3-45
Starting- Portable Fire Pump	2-2-201
Steering.....	2-2-58
Automatic Steering.....	2-2-61
Non-follow-up Steering.....	2-2-60
Normal Steering.....	2-2-59
Steering Shutdown	2-2-62
Steering Controller.....	3-T3-84
Steering Control Panel.....	3-T3-90
Steering Control Panel.....	7-3-215
Steering Control Panel and Gyro Computer	11-5-114, 11-6-3
Steering Cub Hydraulic Pump.....	3-T3-85
Steering Gear Compartment - Controls and Indicators.....	1-2-14
- Interior Arrangement.....	1-1-35
Steering Rudder Repeatback Unit - Principles of Operation	1-1-64
Steering Shutdown	2-2-62
Steering System	7-3-203
Hydraulic Cylinder and Linkage.....	7-3-210
Hydraulic Hoses, Piping and Valves.....	7-3-211
Steering Systems	11-5-102
Flanking Rudder Limit Switch.....	11-5-113
Heading Selector.....	11-5-115
Hydraulic Cub Pump Unit - Brake Valve.....	11-5-106
Hydraulic Cub Pump Unit - Controller	11-5-104
Hydraulic Cub Pump Unit- Cylinder and Linkage.....	11-5-108
Hydraulic Cub Pump Unit - Hoses, Piping and Valves.....	11-5-109
Hydraulic Cub Pump Unit - Motor.....	11-5-103
Hydraulic Cub Pump Unit- Pump	11-5-105
Hydraulic Cub Pump Unit - Reservoir, Tank and Strainer	11-5-107

INDEX (Continued)

Volume - Chapter
- Paragraph
or Table

S (continued)

Steering Systems (Continued)	
Main and Flanking Rudders.....	11-5-110
Remote Magnetic Heading Compass	11-5-116
Rudder Angle Indicator.....	11-5-111
Rudder Angle Transmitter	11-5-112
Ship's Course Indicator.....	11-5-117
Steering Control Panel and Gyro Computer.....	11-5-114
Steering System - Hydraulic Directional Control	
Valve	3-T3-86
Stern Anchor Hydraulic System	11-5-99
Hose and Fittings	11-5-101
Hydraulic Control.....	11-5-97
Hydraulic Winch.....	11-5-100
Stern Gate.....	10-5-54
Stern Gate Controls - Controls and Indicators	1-2-18
Stern Gate - Davits.....	2-2-165
- Emergency Procedures.....	2-2-190
- External Orientation	1-1-20
- Lowering	2-2-68
- Raising.....	2-2-69
Stern Gate Hydraulic Directional Control Valve.....	7-3-194
Stern Gate Hydraulic Hoses, Fittings and Piping.....	7-3-195
Stern Gate Hydraulic Ram.....	7-3-196
Stern Gate Hydraulic System.....	3-T3-81
Stern Gate Hydraulic System.....	11-5-91
Hose, Fittings, and Piping.....	11-5-93
Hydraulic Control.....	11-5-92
Hydraulic Cylinder.....	11-5-94
Stern Gate - Overall.....	10-5-53
Gate Hinges and Springs.....	10-5-55
Portable Davit	10-5-56
Stern Gate	10-5-54
Stern Gate Overall.....	6-3-124
Gate, Hinge, Springs.....	6-3-126
Portable Davit	6-3-127
Stern Gate	6-3-125
Stop Cable and Linkage.....	6-3-141.3
Stopping Generator - Operating Non-Parallel.....	2-2-43
- Operating Parallel	2-2-44
Stopping and Storage - Portable Fire Pump.....	2-2-203
Strainer.....	8-4-52

INDEX (Continued)

Volume - Chapter
- Paragraph
or Table

S (continued)

Switch.....	5-3-110
Break Glass Station	5-3-110.2
Disconnect Switch.....	5-3-110.6
Duplex Receptacles	5-3-110.4
Interlock Door Operated Switch.....	5-3-110.5
Toggle Switch	5-3-110.1
Water Tight Receptacles.....	5-3-110.3
Switchboard.....	3-T3-43
Switchboard (Main).....	5-3-59
Switchboard - Principles of Operation.....	1-1-49
Symptom Index - Troubleshooting	3-3-5
Synchronizing Motor	5-3-66.3
System Alarms	2-2-116
System Shutdown - Air Conditioning.....	2-2-113
System Startup - Air Conditioning	2-2-112

T

Tachometer Drive - Anchor Winch.....	6-3-155
Tachometer Drive - Generator	5-3-80
Tachometer Drive - Propulsion	4-3-23
Tank Assembly - Hydraulic Tank - Anchor Winch.....	6-3-137.1
Tank and Auxiliary Machinery Compartment - Controls and Indicators.....	1-2-9
Tank Level Indicators	11-5-172
Tank Level Indicating System	2-2-75
Tank Level Indicating System - Principles of Operation	1-1-83
Tanks and Voids.....	9-4-66
Tank Level Indication - Cable Assembly.....	9-4-66.3
Tank Level Indication - Penetration Assembly.....	9-4-66.4
Tank Level Indication - Receiver	9-4-66.1
Tank Level Indication - Transmitter	9-4-66.2
Technical Principles of Operation - General.....	1-1-140
Anchor Winch Systems.....	1-1-52
Bow Ramp Systems.....	1-1-58
Communication Systems.....	1-1-86
Hydraulic Starting Systems.....	1-187
Interior Communication Systems.....	1-1-84
Navigation Systems	1-1-85

INDEX (Continued)

Volume - Chapter
- Paragraph
or Table

T (continued)

Technical Principles of Operation - General
(Continued)

Piping Systems	1-1-66
Propulsion Systems.....	1-1-41
Kort Nozzles, Rudders and Fences	1-1-45
Marine Gear.....	1-1-43
Propeller Shafts And Miscellaneous Components.....	1-1-44
Propulsion Engine	1-1-42
Ship's Service Generating System	1-1-46
Generator.....	1-1-48
Generator Engine.....	1-1-47
Lighting Distribution.....	1-1-51
Power Distribution	1-1-50
Switchboard	1-1-49
Steering Systems.....	1-1-59
Terminal Boxes.....	5-3-109.2
Thermal Expansion Valve - Air Conditioning.....	9-4-35
Thermometers	9-4-36.5
Thermostats	8-4-28.3
Thermostat and Housing - Anchor Winch.....	11-5-75
Thermostat and Housing - Generator.....	10-5-39
Thermostat and Housing - Propulsion	1-5-12
Thermostat and Housing - Anchor Winch.....	6-3-153
Thermostat and Housing - Generator.....	5-3-78
Thermostat and Housing - Propulsion	4-3-22
Thermostat Switch and Magazine Alarm.....	11-5-153
Time Delay Relay	5-3-65.3.1
Toaster	2-2-134,9-4-45
Toggle Switch.....	5-3-110.1
Toilet	8-4-19
Torque Converter	3-T3-51
Torque Converter	10-5-66
Torque Converter	6-3-136
Torque Converter - Principles of Operation.....	1-1-54
Torque Coupling - Bow Ramp.....	6-3-118
Transformer	5-3-60
Transformers	10-5-30
24-Volt Rectifier.....	10-5-44

INDEX (Continued)

Volume - Chapter
- Paragraph
or Table

U

Universal Joint Assembly.....	10-5-59
Urinal	8-4-17
Urinal	8-4-17.1
Urinal Discharge Valve.....	8-4-17.2
Urinal Flushing Valve	8-4-17.3
Used Engine Oils.....	2-2-103

V

Vacuum Pump - Sewage System.....	11-5-131
Valve and Injector Operating Mechanism - Exhaust	
Valves - Anchor Winch.....	6-3-165
Exhaust Valve	6-3-165.2
Valve and Injector Operating Mechanism.....	6-3-165.1
Valve and Injector Operating Mechanism - Exhaust	
Valves - Generator	5-3-90
Exhaust Valve.....	5-3-90.2
Valve and Injector Operating Mechanism.....	5-3-90.1
Valve and Injector Operating Mechanism	4-3-33
Exhaust Valve	4-3-33.2
Valve and Injector Operating Mechanism	4-3-33.1
Valve Rocker Arm Cover - Generator	5-3-86
Valve Rocker Arm Cover- Propulsion.	4-3-30
Variable Speed Mechanical Governor.....	10-5-7
Ventilating Fans.....	2-2-120
Vent Piping - Sewage System.....	8-4-22.1
Vents and Soundings.....	9-4-69
Vents and Sounding Tubes.....	11-5-174
VHF Antenna.....	9-4-50,11-5-157
Voice Tube	2-2-157
Voice Tube	9-4-47.4
24 Volt Distribution Panel	9-4-49.3
Voltage Regulator.....	10-5-29.1
Voltage Regulator.....	5-3-62.2

INDEX (Continued)

Volume - Chapter
- Paragraph
or Table

W

Wake Light.....	5-3-113.10
Washdown Countermeasure Sprinkling System.....	2-2-82, 8-4-61
Washer/Dryer.....	9-4-42
Dryer Mechanism.....	9-4-42.3
Exterior Cabinet Removal.....	9-4-42.1
Washer/Dryer Controls.....	9-4-42.4
Washer Mechanism.....	9-4-42.2
Washer/Dryer Controls.....	9-4-42.4
Washer/Dryer Turn ON/OFF.....	2-2-143
Washer Mechanism.....	9-4-42.2
Washer Operation.....	2-2-144
Wash Room, Water Closet and Shower - Controls and Indicators.....	1-2-4
Wash Room, Water Closet and Shower - Interior Arrangement.....	1-1-25
Wash Room, Water Closet and Shower.....	2-2-142
Dryer Operation.....	2-2-145
Washer/Dryer Turn ON/OFF.....	2-2-143
Washer Operation.....	2-2-144
Water Closet.....	4-8-16
Water Closet.....	4-8-16.1
Water Closet.....	4-8-16.2
Water Connections - Anchor Winch.....	6-3-151
Water Connections - Propulsion.....	4-3-20
Water Temperature Alarm Switch.....	5-3-65.3.2
Water Temperature Switch.....	4-3-9.4
Water Manifold - Anchor Winch.....	11-5-74
Water Manifold - Generator.....	10-5-38
Water Manifold - Propulsion.....	10-5-11
Water Manifold - Anchor Winch.....	6-3-152
Water Manifold - Generator.....	5-3-77
Water Manifold - Propulsion.....	4-3-21
Water Regulating Valve.....	9-4-36.4
Watertight Integrity.....	2-2-208
Water Tight Receptacles.....	5-3-110.3
Whip Antennas.....	2-2-160
Winch - Anchor Winch.....	3-T3-48
Winch Assembly.....	10-5-49
Winch Assembly - Bow Ramp.....	6-3-117
Winch Brake and Motor - Bow Ramp.....	6-3-120
Winch Motor.....	10-5-51

INDEX (Continued)

W (Continued)	Volume - Chapter -Paragraph or Table
Windscreen and Railings	2-2-163
Windscreen and Airports.....	9-4-75
Windshield Wiper	2-2-128
Windshield Wiper	2-128.2-666.1
	9-4-78
Windshield Wiper Assembly (Pilothouse)	9-4-78.2
Windshield Wiper Control (Pilothouse).....	9-4-78.1
Windshield Wiper Motor (Pilothouse).....	9-4-78.3
Windshield Wiper Assembly (Conning Tower).....	9-4-78.4
Windshield Wiper Control (Conning Tower).....	9-4-78.5
Wire Rope Cutter.....	7-3-184
Wire Rope Guard and Slack Cable Interlock Limit Switch Bracket	6-3-123.3
Wye Strainer	9-4-54.4

*U.S. GOVERNMENT PRINTING OFFICE: 1992 - 654.028/60016

By Order of the Secretary of the Army:

JOHN A. WICKHAM, JR.
General, United States Army
Chief of Staff

Official:

DONALD J. DELANDRO
Brigadier General, United States Army
The Adjutant General

DISTRIBUTION:

To be distributed in accordance with DA Form 12-25D, Operator, Organizational, Direct and General Support Maintenance Requirements for Marine Equipment, All.

These are the instructions for sending an electronic 2028

The following format must be used if submitting an electronic 2028. The subject line must be exactly the same and all fields must be included; however only the following fields are mandatory: 1, 3, 4, 5, 6, 7, 8, 9,10,13,15,16,17, and 27.

From: "Whomever" <whomever@avma27.army.mil>
To: mpmt/oavma28@st-louis-emh7.army.mil

Subject DA Form 2028

1. **From:** Joe Smith
2. **Unit:** home
3. **Address:** 4300 Park
4. **City:** Hometown
5. **St:** MO
6. **Zip:** 77777
7. **Date Sent:** 19-OCT-93
8. **Pub no:** 55-2840-229-23
9. **Pub Title:** TM
10. **Publication Date:** 04-JUL-85
11. **Change Number:** 7
12. **Submitter Rank:** MSG
13. **Submitter FName:** Joe
14. **Submitter MName:** T
15. **Submitter LName:** Smith
16. **Submitter Phone:** 123-123-1234
17. **Problem:** 1
18. **Page:** 2
19. **Paragraph:** 3
20. **Line:** 4
21. **NSN:** 5
22. **Reference:** 6
23. **Figure:** 7
24. **Table:** 8
25. **Item:** 9
26. **Total:** 123
27. **Text:**

This is the text for the problem below line 27.

RECOMMENDED CHANGES TO EQUIPMENT TECHNICAL PUBLICATIONS



THEN...JOT DOWN THE DOPE ABOUT IT ON THIS FORM. CAREFULLY TEAR IT OUT, FOLD IT AND DROP IT IN THE MAIL.

SOMETHING WRONG WITH PUBLICATION

FROM: (PRINT YOUR UNIT'S COMPLETE ADDRESS)

DATE SENT

PUBLICATION NUMBER

PUBLICATION DATE

PUBLICATION TITLE

BE EXACT PIN-POINT WHERE IT IS

PAGE NO.

PARA-GRAPH

FIGURE NO.

TABLE NO.

IN THIS SPACE, TELL WHAT IS WRONG AND WHAT SHOULD BE DONE ABOUT IT.

TEAR ALONG PERFORATED LINE

PRINTED NAME, GRADE OR TITLE AND TELEPHONE NUMBER

SIGN HERE

The Metric System and Equivalents

Linear Measure

1 centimeter = 10 millimeters = .39 inch
 1 decimeter = 10 centimeters = 3.94 inches
 1 meter = 10 decimeters = 39.37 inches
 1 dekameter = 10 meters = 32.8 feet
 1 hectometer = 10 dekameters = 328.08 feet
 1 kilometer = 10 hectometers = 3,280.8 feet

Weights

1 centigram = 10 milligrams = .15 grain
 1 decigram = 10 centigrams = 1.54 grains
 1 gram = 10 decigrams = .035 ounce
 1 dekagram = 10 grams = .35 ounce
 1 hectogram = 10 dekagrams = 3.52 ounces
 1 kilogram = 10 hectograms = 2.2 pounds
 1 quintal = 100 kilograms = 220.46 pounds
 1 metric ton = 10 quintals = 1.1 short tons

Liquid Measure

1 centiliter = 10 milliliters = .34 fl. ounce
 1 deciliter = 10 centiliters = 3.38 fl. ounces
 1 liter = 10 deciliters = 33.81 fl. ounces
 1 dekaliter = 10 liters = 2.64 gallons
 1 hectoliter = 10 dekaliters = 26.42 gallons
 1 kiloliter = 10 hectoliters = 264.18 gallons

Square Measure

1 sq. centimeter = 100 sq. millimeters = .155 sq. inch
 1 sq. decimeter = 100 sq. centimeters = 15.5 sq. inches
 1 sq. meter (centare) = 100 sq. decimeters = 10.76 sq. feet
 1 sq. dekameter (are) = 100 sq. meters = 1,076.4 sq. feet
 1 sq. hectometer (hectare) = 100 sq. dekameters = 2.47 acres
 1 sq. kilometer = 100 sq. hectometers = .386 sq. mile

Cubic Measure

1 cu. centimeter = 1000 cu. millimeters = .06 cu. inch
 1 cu. decimeter = 1000 cu. centimeters = 61.02 cu. inches
 1 cu. meter = 1000 cu. decimeters = 35.31 cu. feet

Approximate Conversion Factors

<i>To change</i>	<i>To</i>	<i>Multiply by</i>	<i>To change</i>	<i>To</i>	<i>Multiply by</i>
inches	centimeters	2.540	ounce-inches	newton-meters	.007062
feet	meters	.305	centimeters	inches	.394
yards	meters	.914	meters	feet	3.280
miles	kilometers	1.609	meters	yards	1.094
square inches	square centimeters	6.451	kilometers	miles	.621
square feet	square meters	.093	square centimeters	square inches	.155
square yards	square meters	.836	square meters	square feet	10.764
square miles	square kilometers	2.590	square meters	square yards	1.196
acres	square hectometers	.405	square kilometers	square miles	.386
cubic feet	cubic meters	.028	square hectometers	acres	2.471
cubic yards	cubic meters	.765	cubic meters	cubic feet	35.315
fluid ounces	milliliters	29.573	cubic meters	cubic yards	1.308
pints	liters	.473	milliliters	fluid ounces	.034
quarts	liters	.946	liters	pints	2.113
gallons	liters	3.785	liters	quarts	1.057
ounces	grams	28.349	liters	gallons	.264
pounds	kilograms	.454	grams	ounces	.035
short tons	metric tons	.907	kilograms	pounds	2.205
pound-feet	newton-meters	1.356	metric tons	short tons	1.102
pound-inches	newton-meters	.11296			

Temperature (Exact)

°F	Fahrenheit temperature	5/9 (after subtracting 32)	Celsius temperature	°C
----	---------------------------	-------------------------------	------------------------	----

PIN: 057585-002